

HOOGTE BESTAAND	
AFSTAND BESTAAND	

LANGSDOORSNEDE A-A
SCHAAL 150

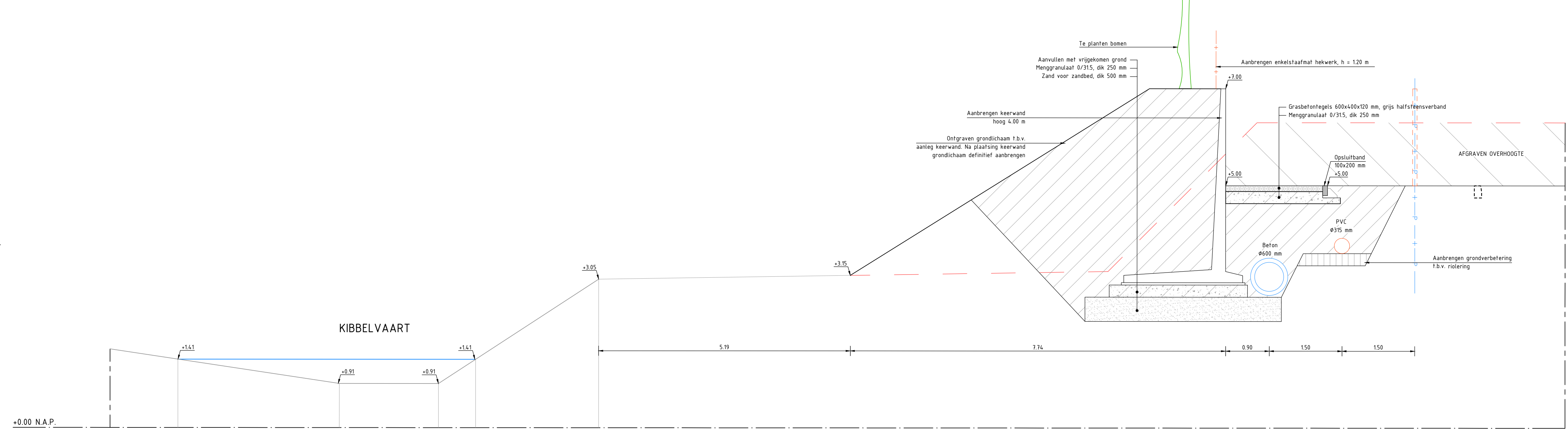

HOOGTE BESTAAND	
AFSTAND BESTAAND	

DOORSNEDE 9-9
SCHAAL 150

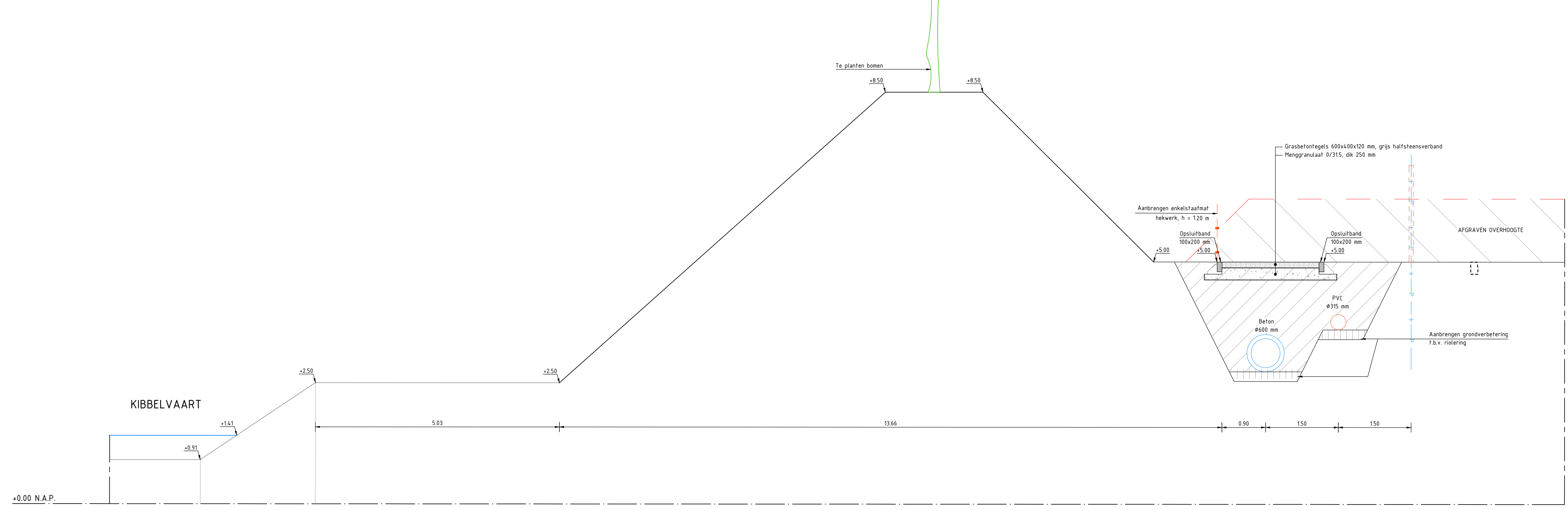

HOOGTE BESTAAND	
AFSTAND BESTAAND	

DOORSNEDE 10-10
SCHAAL 150

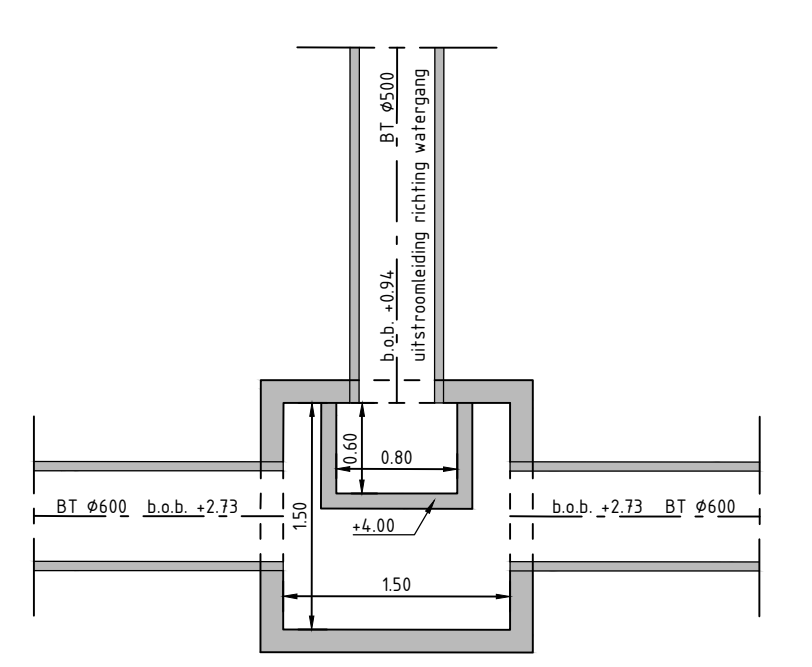

DETAIL 1: OVERSTORTPUT
SCHAAL 150

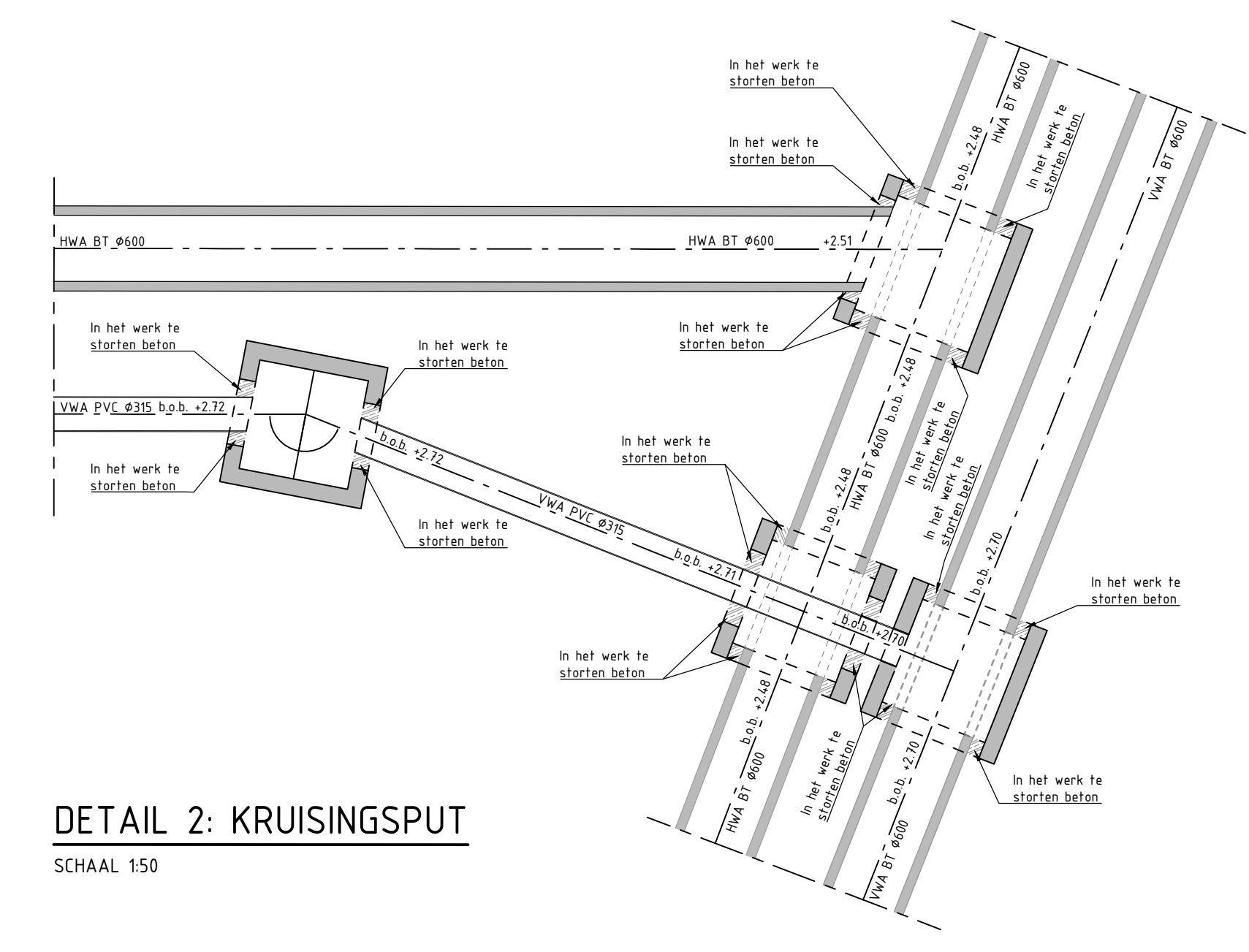

DETAIL 2: KRUISINGSPUT
SCHAAL 150

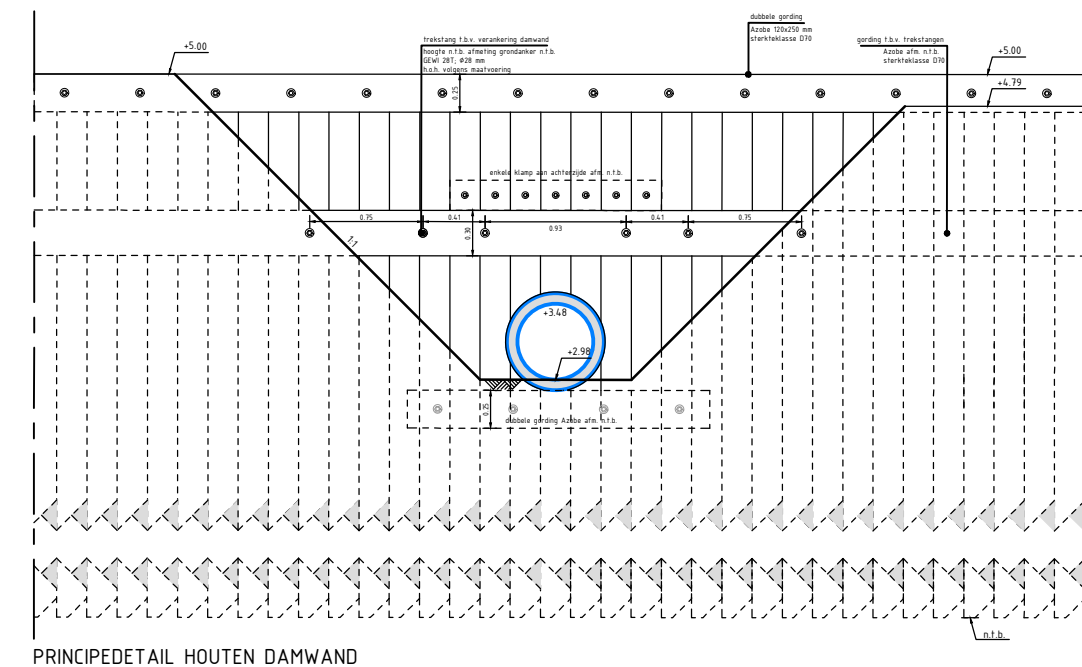

PRINCIPEDETAIL HOUTEN DAMWAND

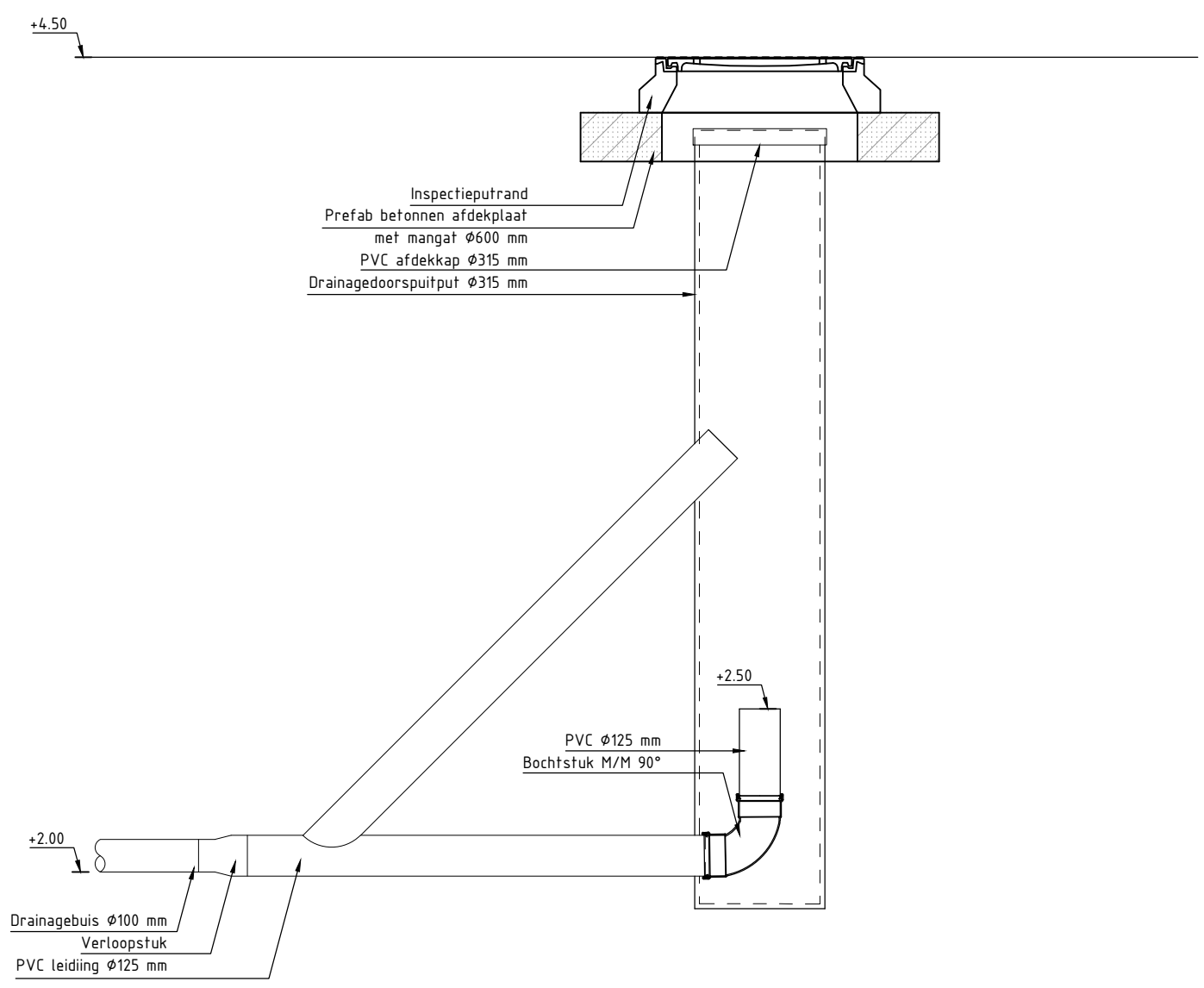

DETAIL DRAINAGEPUT MET INSTELNIVEAU
SCHAAL 120

0 5 10 15 20m
MATEN IN METERS TENZIJ ANDERS VERMELD
HOOGTEMATEN IN METERS TEN OPZICHT VAN N.A.P.
MATERIALEN IN MILLIMETERS TENZIJ ANDERS VERMELD

WBD24-831949-D

Project: **UITBREIDING DC ETTEN-LEUR**
Onderdeel: **DWARSPROFIELEN FASE 2C BLAD 2 VAN 2**

Datum: 26-09-2024 | Vormaat: A0 | Schaal: 1:200

Fase: **BESTEK** | Toestand: **DEFINITIEF 3.0** | Tekeningnummer: **22-606-01-TEK-BST-30**

Opdrachtgever: **UUF Houtenland GmbH**
Postbus 156
1270 AD Huzen

Maas & Nienhuis
ontwerpbureau