

LANGSDOORSNEDE

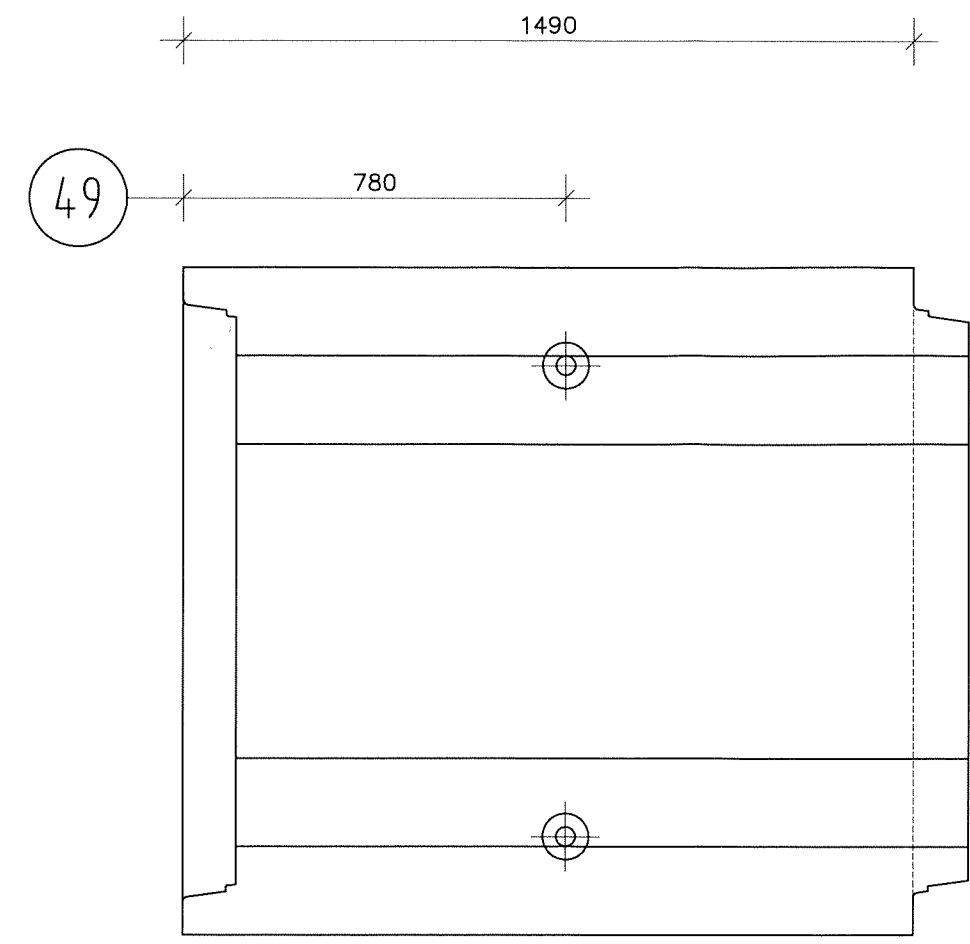

DWARSDOORSNEDE

LET OP:
wapeningvrij gebied van 100x100 mm
in buitennet III rondom hijsankers

Buigmaten

NET nr.	KNIPLENGTE L	
NET I	1500	
NET II	KNIPLENGTE L	1250
	Buigmaat a	95
	Buigmaat b	1060
NET III	KNIPLENGTE L	2240
	Buigmaat a	470
	Buigmaat b	1300
NET IV	KNIPLENGTE L	1000

NET nr.	WAPENING	V.W.
NET I	∅8-100	∅6-250
NET II	∅8-100	∅6-250
NET III	∅8-100	∅6-250
NET IV	∅8-100	∅6-250

pos nr.	aantal	omschrijving	wapening bovenaanzicht vloeren		wapening vooraanzicht wanden	
			1e laag boven	2e laag onder	2e laag voor	1e laag achter
49	4	DEHA hijsanker 6000-5.0-120	▽	▽	▽	▽
			▽M	▽M	▽R	▽R
			▽P	▽S	▽S	▽S
			▽	▽V	▽V	▽V
			▽G			
					↙ V10	= vellingkant 10x10mm

<p>Waco[®] ENGINEERING CONFORM CATEGORIE 3</p>		<p>Postbus 219 4600 AE Bergen op Zoom Lelyweg 23 Telefoon : (0164) 274200 Telefax : (0164) 234364 E-mail : info@waco.nl</p>	
<p>projekt : DUKER te WITTEM</p> <p>onderdeel : MS Duiker 1250x1000</p>	<p>Beton : C50/60</p> <p>Staal : B500B</p>	<p>merk : MS3659</p> <p>aantal : 6</p>	<p>schaal : 1:15</p> <p>ordernr. fabriek : 103659</p> <p>werknr. : 2024-084</p> <p>teknr. : MS3659</p> <p>wijz. : A</p>
<p>inhoud : 1.45 m³</p> <p>gewicht : 3625 kg</p>	<p>Dekking : 30 mm</p> <p>Milieukl. : XC4/XD3/XF4</p>	<p>E</p> <p>D</p> <p>C</p> <p>B</p> <p>A</p> <p>DEFINITIEF</p>	<p>24-04-2024</p> <p>Datum : 24-04-2024</p> <p>Get. Gecontr.</p>

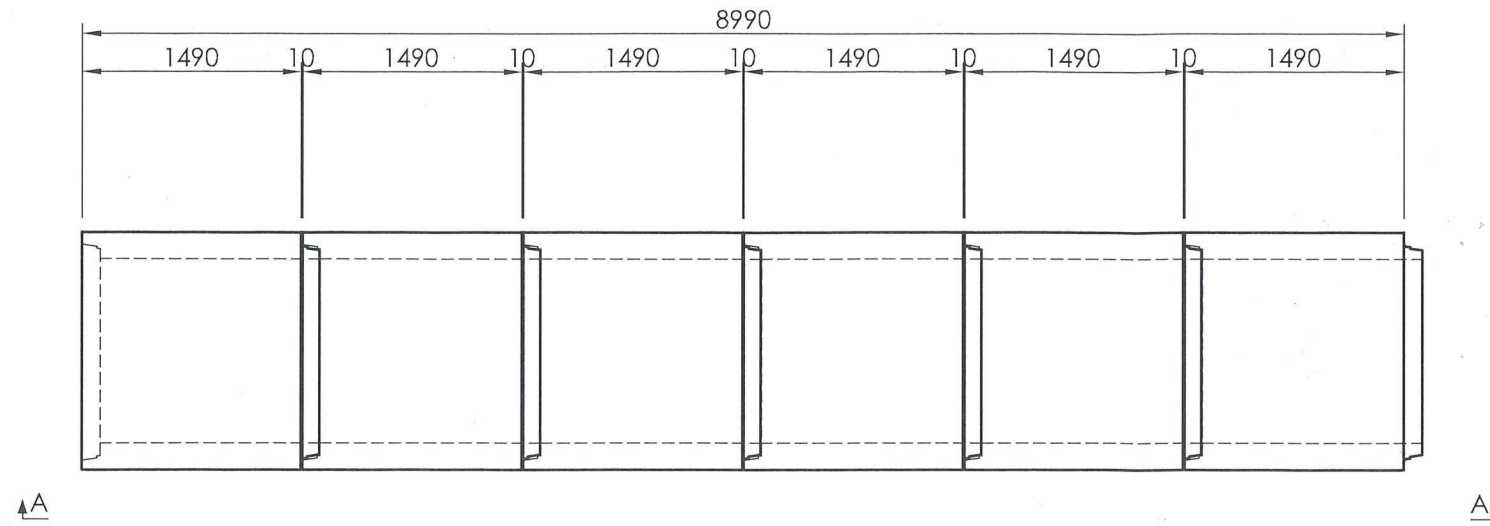

BOVENAANZICHT

← MONTAGERICHTING

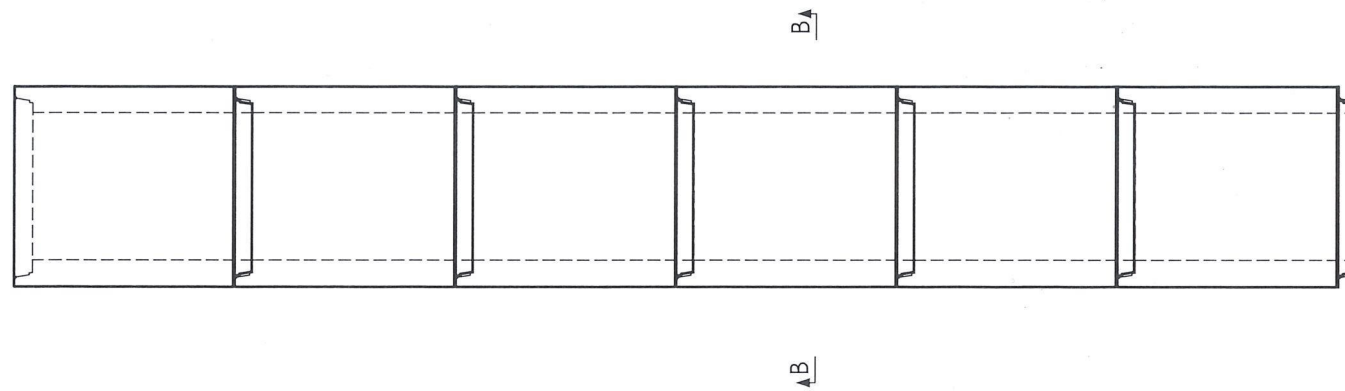

AANZICHT A-A

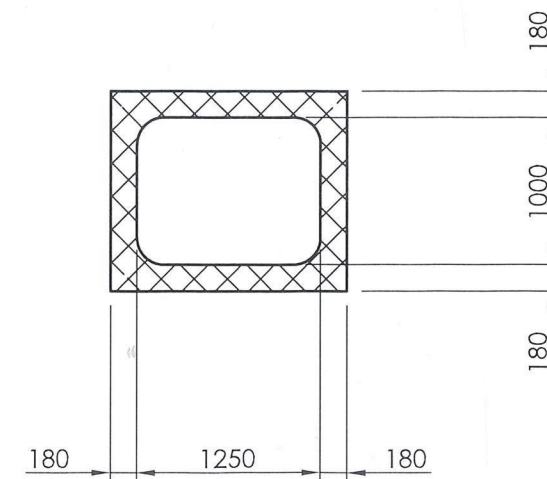

DOORSNEDE B-B

DUIKER - bestaande uit - van rechts naar links:
6 stuks MS duikerelementen 1250 x 1000 Lnom = 1490

[ANDEWEG BOUWTECHNIEK]		 ENGINEERING CONFORM CATEGORIE 3		Postbus 219 4600 AE Bergen op Zoom Lelyweg 23 Telefoon : (0164) 274200 Telefax : (0164) 234364 E-mail : info@waco.nl																																	
				<table border="1"> <tr> <td>E</td> <td></td> <td></td> <td></td> <td></td> <td>schaal: 1:50</td> </tr> <tr> <td>D</td> <td></td> <td></td> <td></td> <td></td> <td>ordernr. fabriek: 103659</td> </tr> <tr> <td>C</td> <td></td> <td></td> <td></td> <td></td> <td>werknr.: 2024-084</td> </tr> <tr> <td>B</td> <td></td> <td></td> <td></td> <td></td> <td>teknr.: OV3659</td> </tr> <tr> <td>A</td> <td>TER CONTROLE</td> <td>24-04-2024</td> <td>...</td> <td></td> <td>wijz.: A</td> </tr> <tr> <td>Editie:</td> <td>Omschrijving:</td> <td>Datum:</td> <td>Get.</td> <td>Gecontr.</td> <td></td> </tr> </table>		E					schaal: 1:50	D					ordernr. fabriek: 103659	C					werknr.: 2024-084	B					teknr.: OV3659	A	TER CONTROLE	24-04-2024	...		wijz.: A	Editie:	Omschrijving:
E					schaal: 1:50																																
D					ordernr. fabriek: 103659																																
C					werknr.: 2024-084																																
B					teknr.: OV3659																																
A	TER CONTROLE	24-04-2024	...		wijz.: A																																
Editie:	Omschrijving:	Datum:	Get.	Gecontr.																																	
project :	DUIKER te WITTEM																																				
onderdeel :	OVERZICHT DUIKER 1250x1000																																				
inhoud (liter) :	Beton :	C50/60	merk :	OV3659																																	
	Staal :	B500B																																			
gewicht (kg) :	Dekking :	30	aantal :	1																																	
	Milieucl. :	XC4/XD3/XF4																																			