

**Normaalprofiel A-A**  
Schaal 1/50

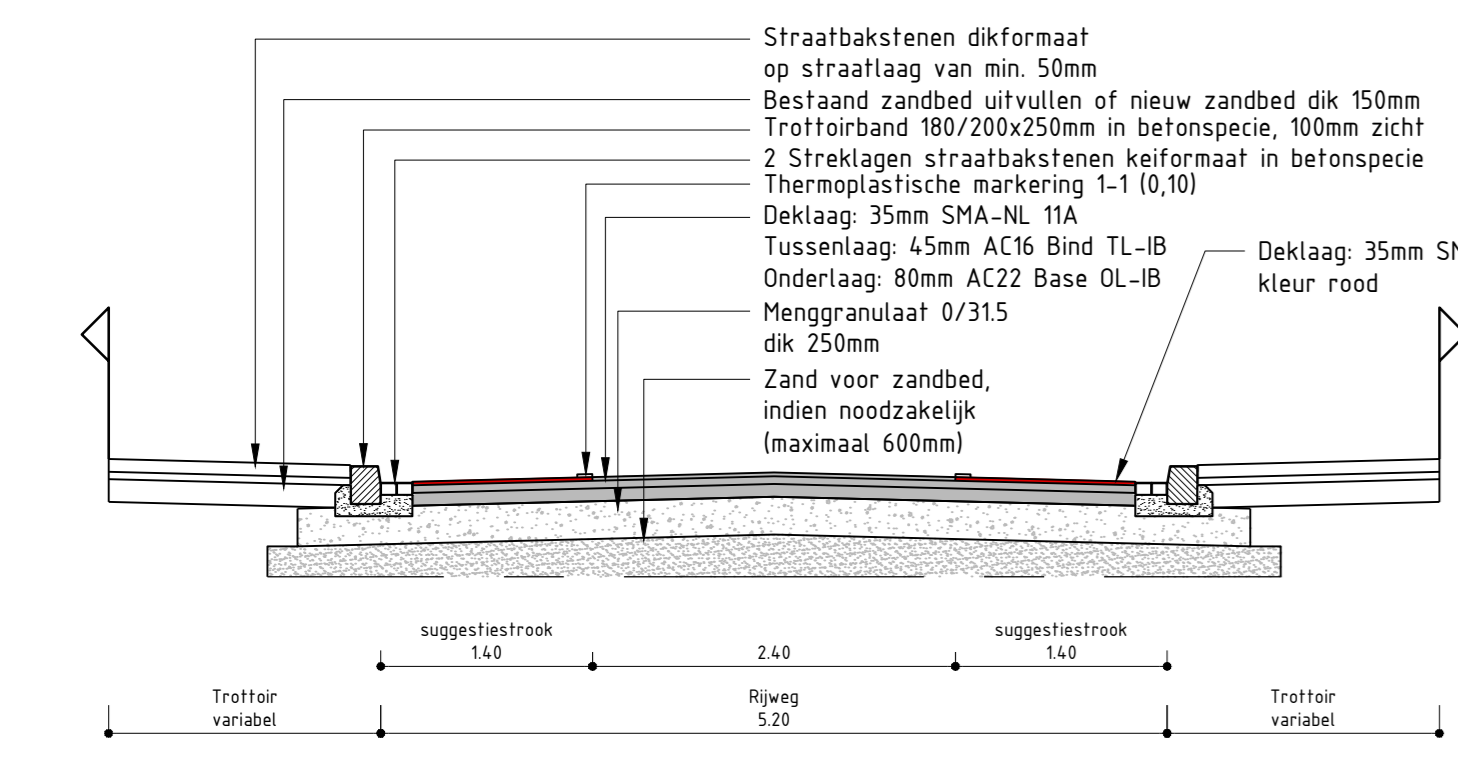

**Normaalprofiel B-B**  
Schaal 1/50

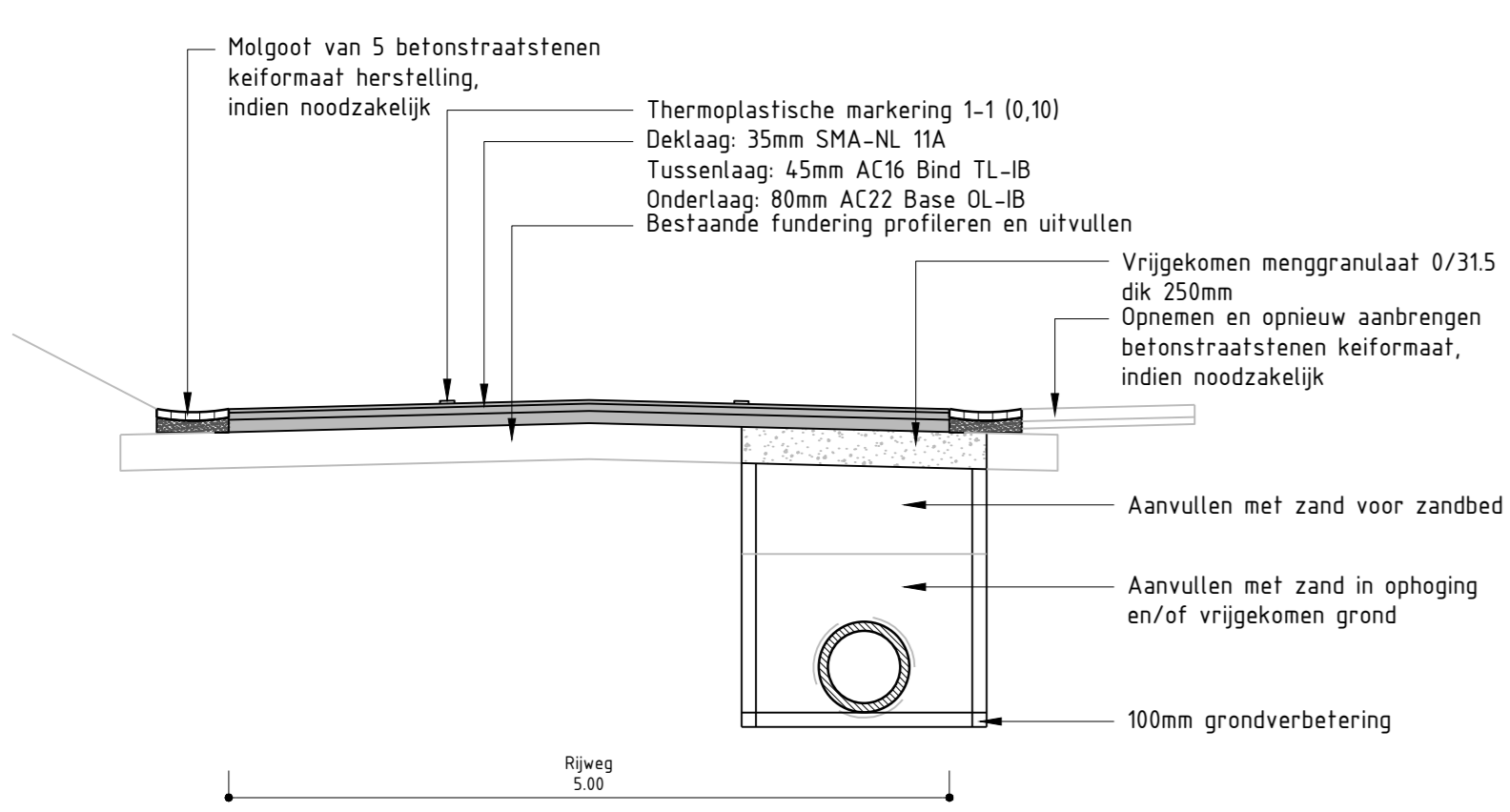

**Normaalprofiel C-C**  
Schaal 1/50

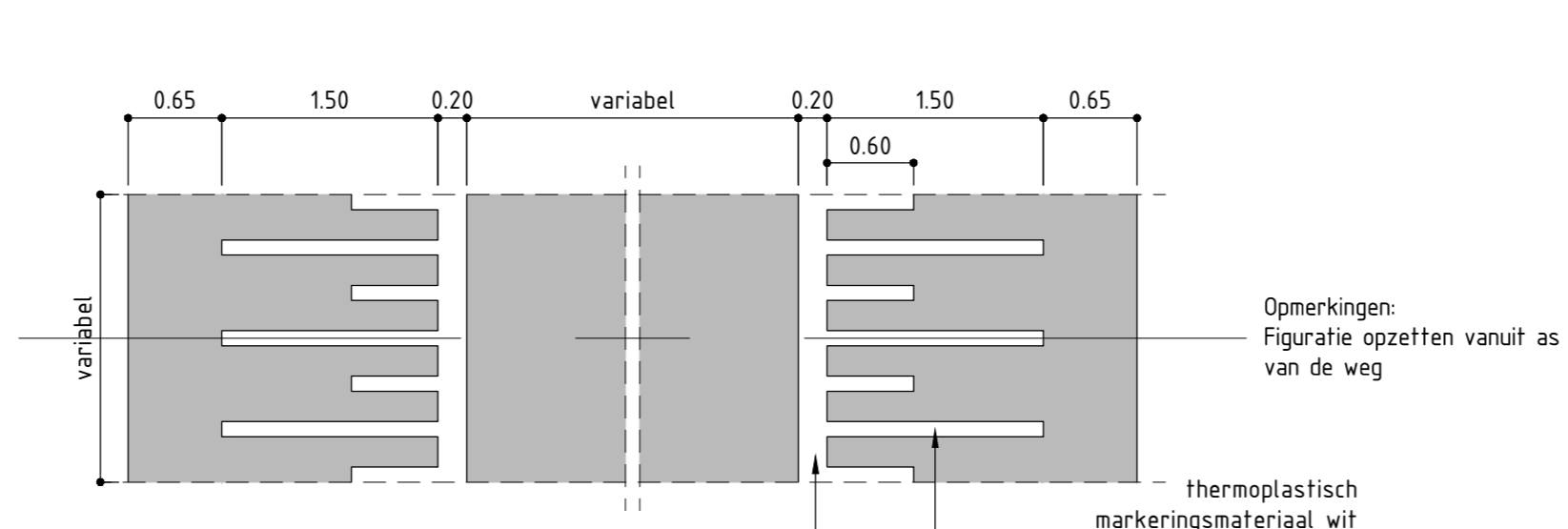

**Dwarsdoorsnede Drempeel 50 km/uur**  
Schaal 1/50

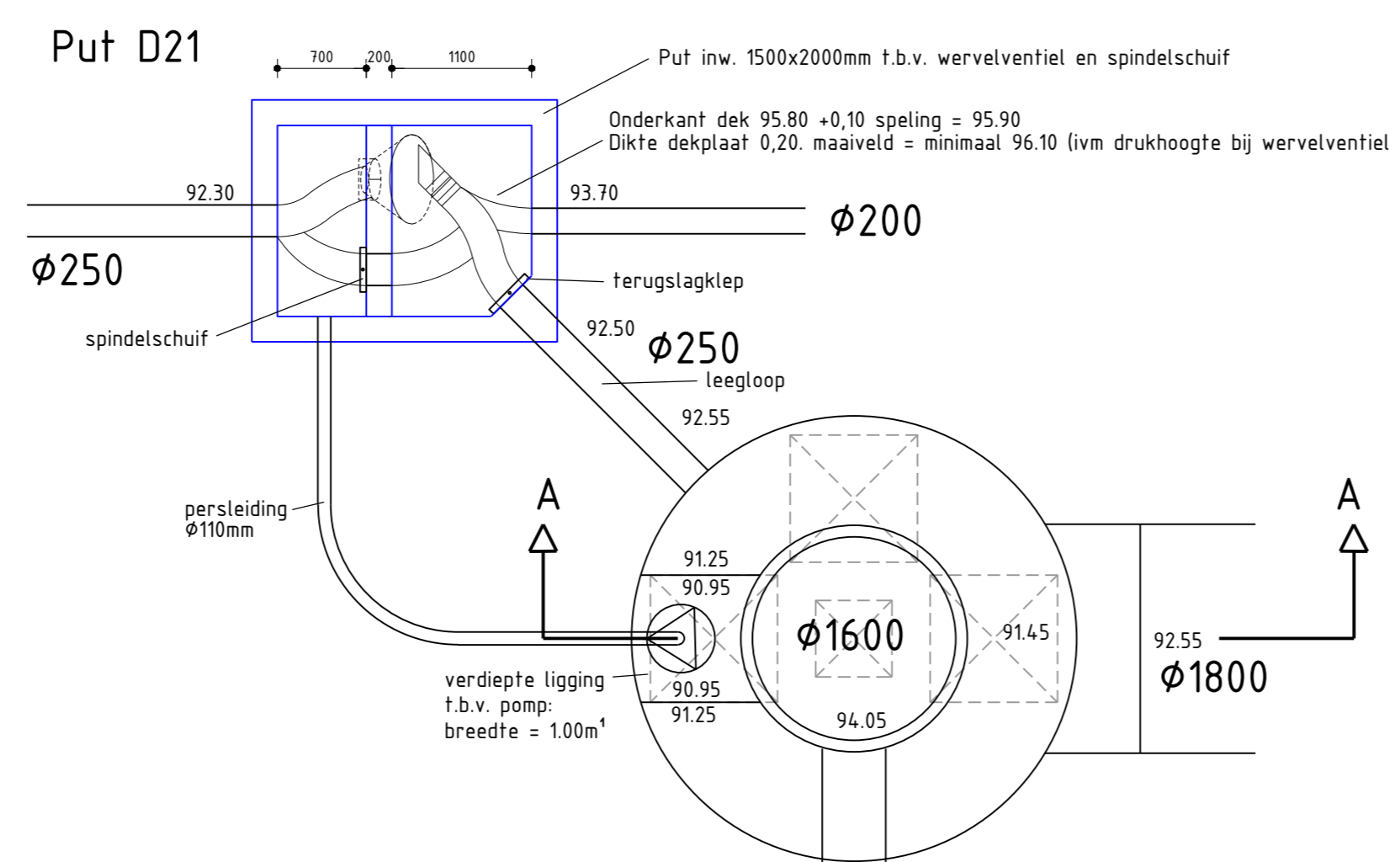

**Doorsnede A-A**

**Principedetail externe overstortput**  
Schaal 1/50

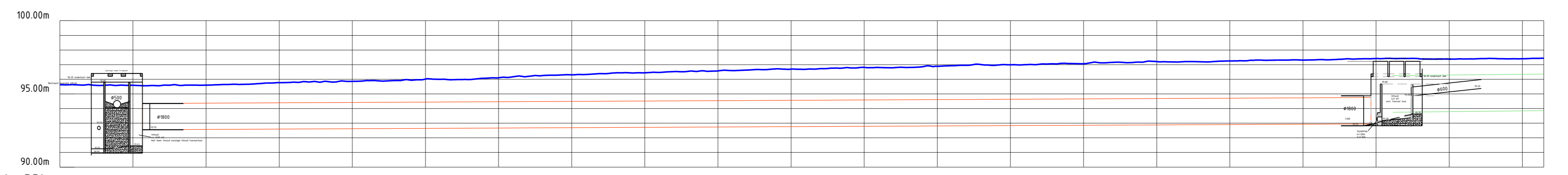

**Lengteprofiel As BBL**  
Vertikale schaal 1:200

Metreering	5000	10000	15000	20000	25000	30000	35000	40000	45000	50000	55000	60000	65000	70000	75000	80000	85000	90000	95000	100000
Bestaande hoogte	95.144	95.142	95.141	95.140	95.139	95.138	95.137	95.136	95.135	95.134	95.133	95.132	95.131	95.130	95.129	95.128	95.127	95.126	95.125	95.124

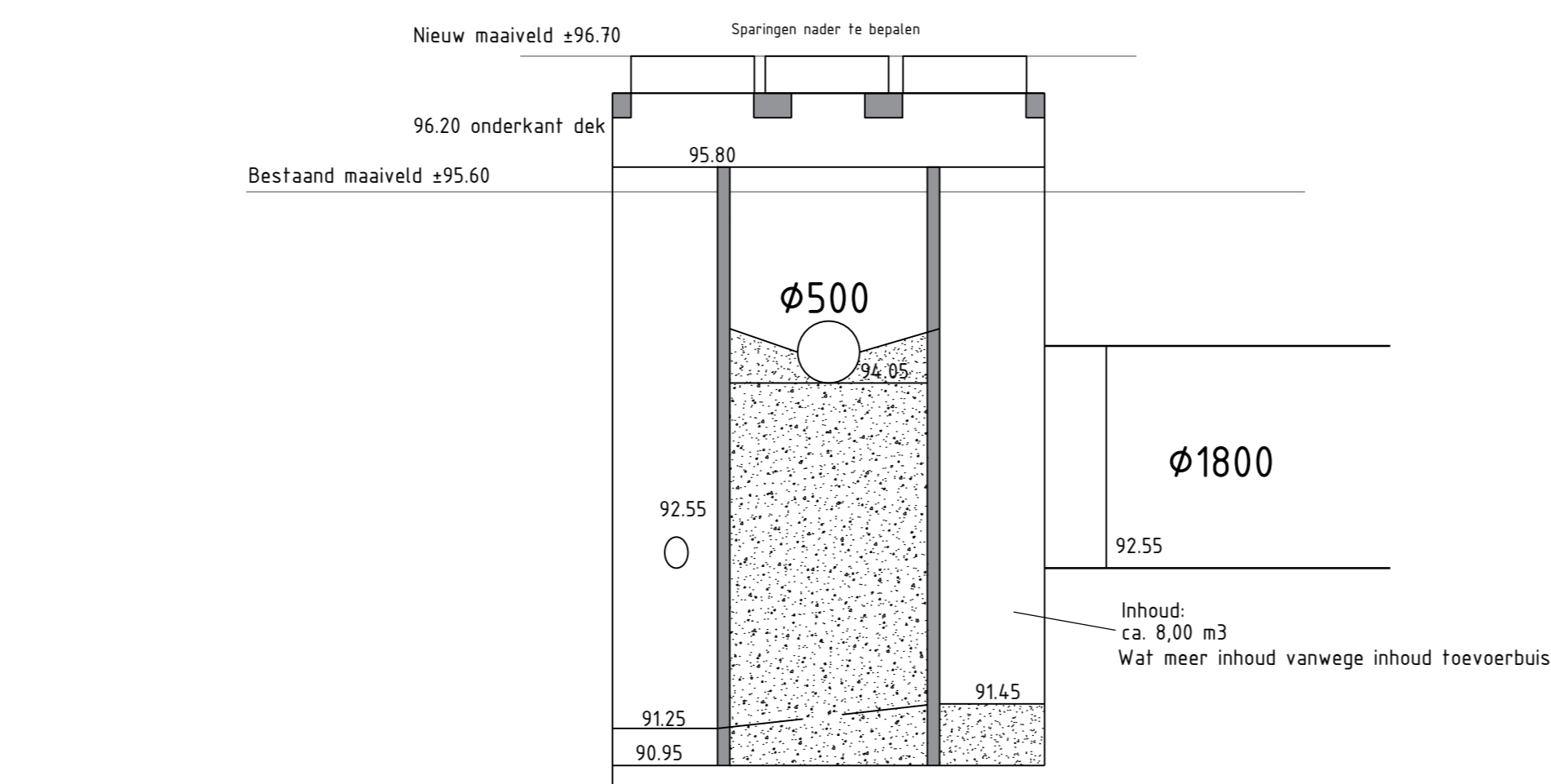

**Doorsnede B-B**

**Principedetail interne overstortput**  
Schaal 1/50

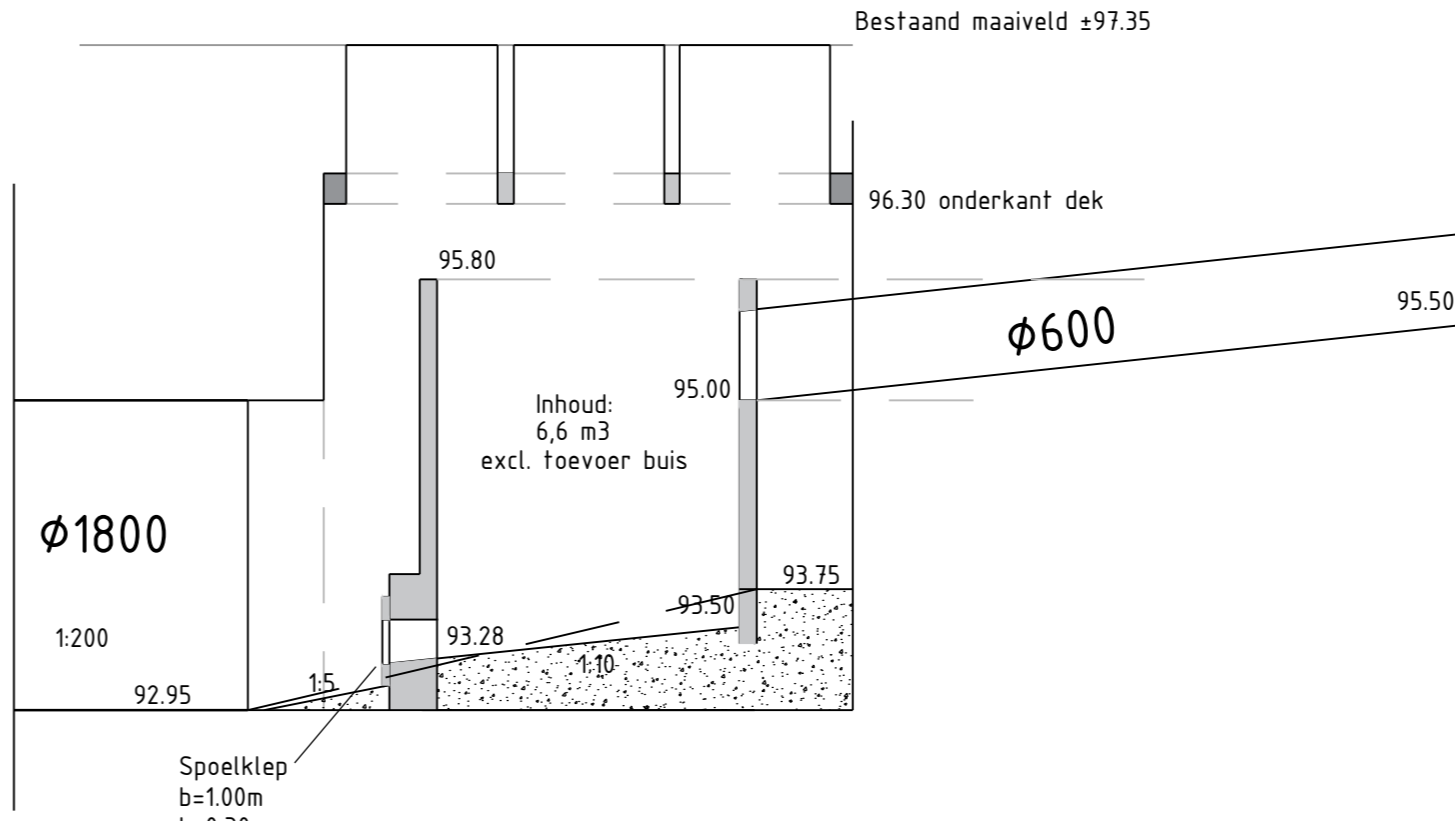

**Dwarsprofiel D-D**  
Schaal 1:200

Hoogte	99.000	99.000	99.000	99.000	99.000	99.000	99.000	99.000	99.000	99.000	99.000	99.000	99.000	99.000	99.000	99.000	99.000	99.000	99.000	99.000
Afstand	-11.022	-11.022	-11.022	-11.022	-11.022	-11.022	-11.022	-11.022	-11.022	-11.022	-11.022	-11.022	-11.022	-11.022	-11.022	-11.022	-11.022	-11.022	-11.022	-11.022

**Dwarsprofiel E-E**  
Schaal 1:200

Hoogte	99.000	99.000	99.000	99.000	99.000	99.000	99.000	99.000	99.000	99.000	99.000	99.000	99.000	99.000	99.000	99.000	99.000	99.000	99.000	99.000
Afstand	-11.022	-11.022	-11.022	-11.022	-11.022	-11.022	-11.022	-11.022	-11.022	-11.022	-11.022	-11.022	-11.022	-11.022	-11.022	-11.022	-11.022	-11.022	-11.022	-11.022

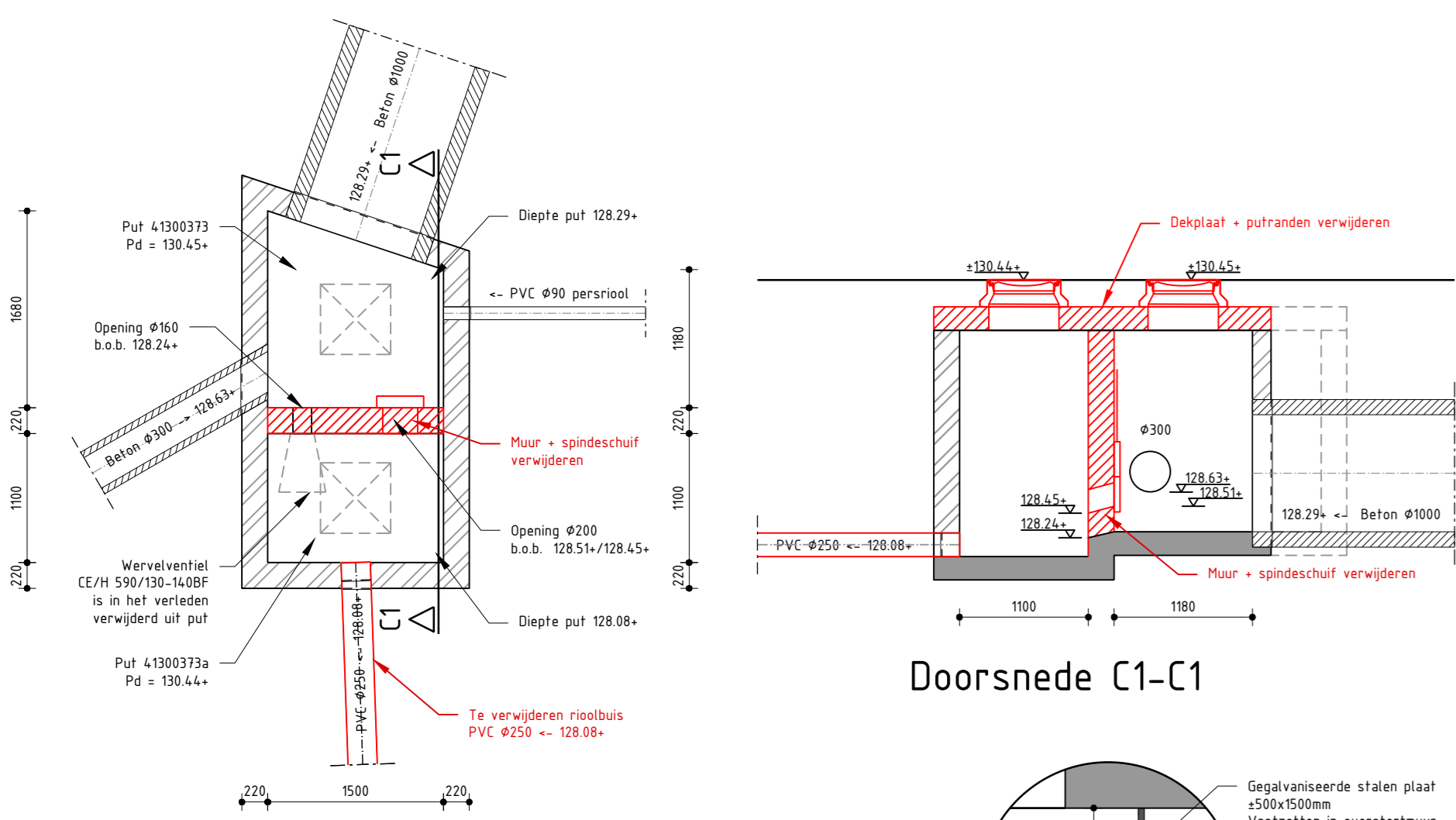

**Revisie put 41300373/41300373a**  
Schaal 1/50

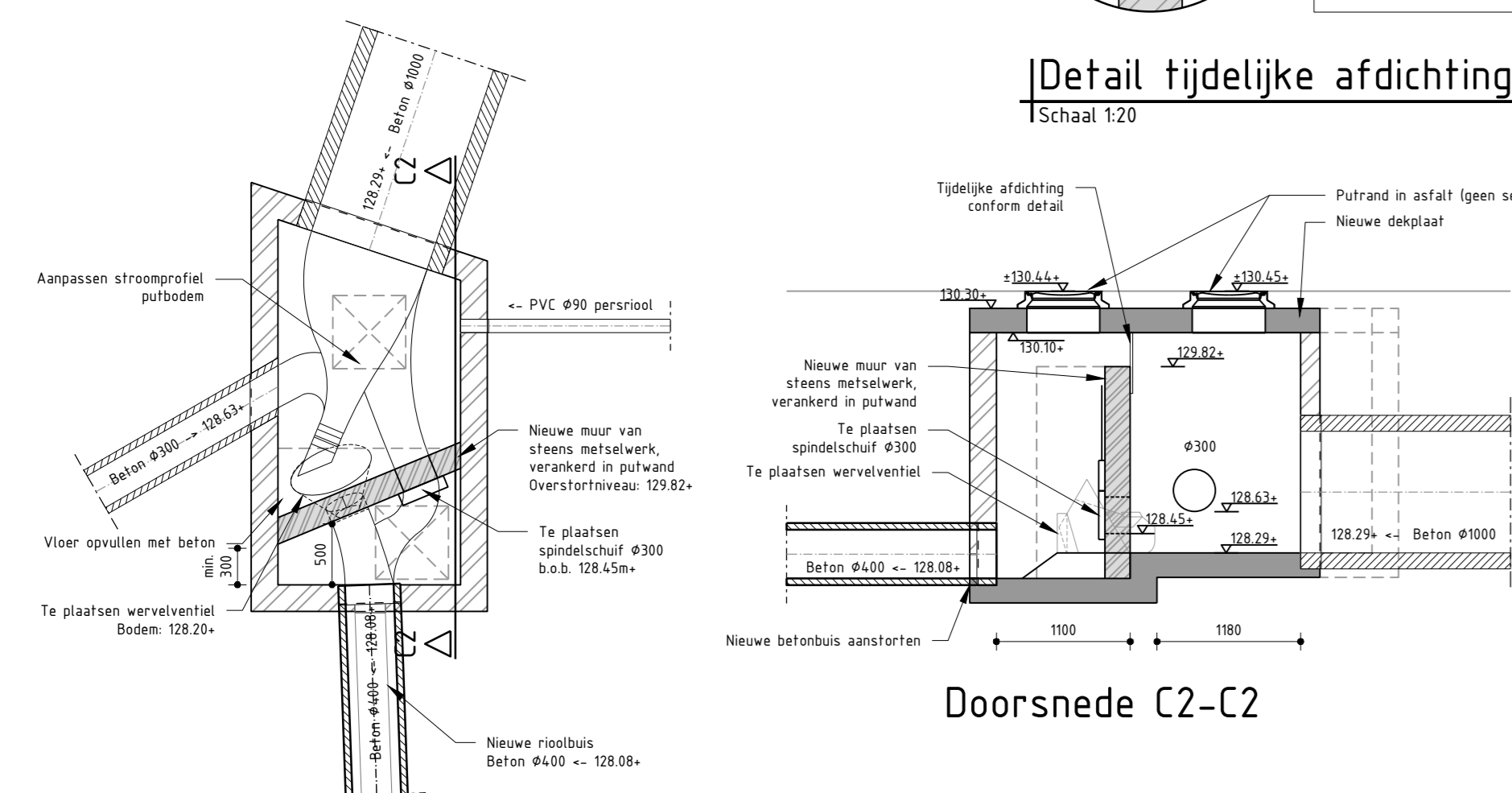

**Detail tijdelijke afdichting**  
Schaal 1/20

**Aangepaste put 41300373/41300373a**  
Schaal 1/50

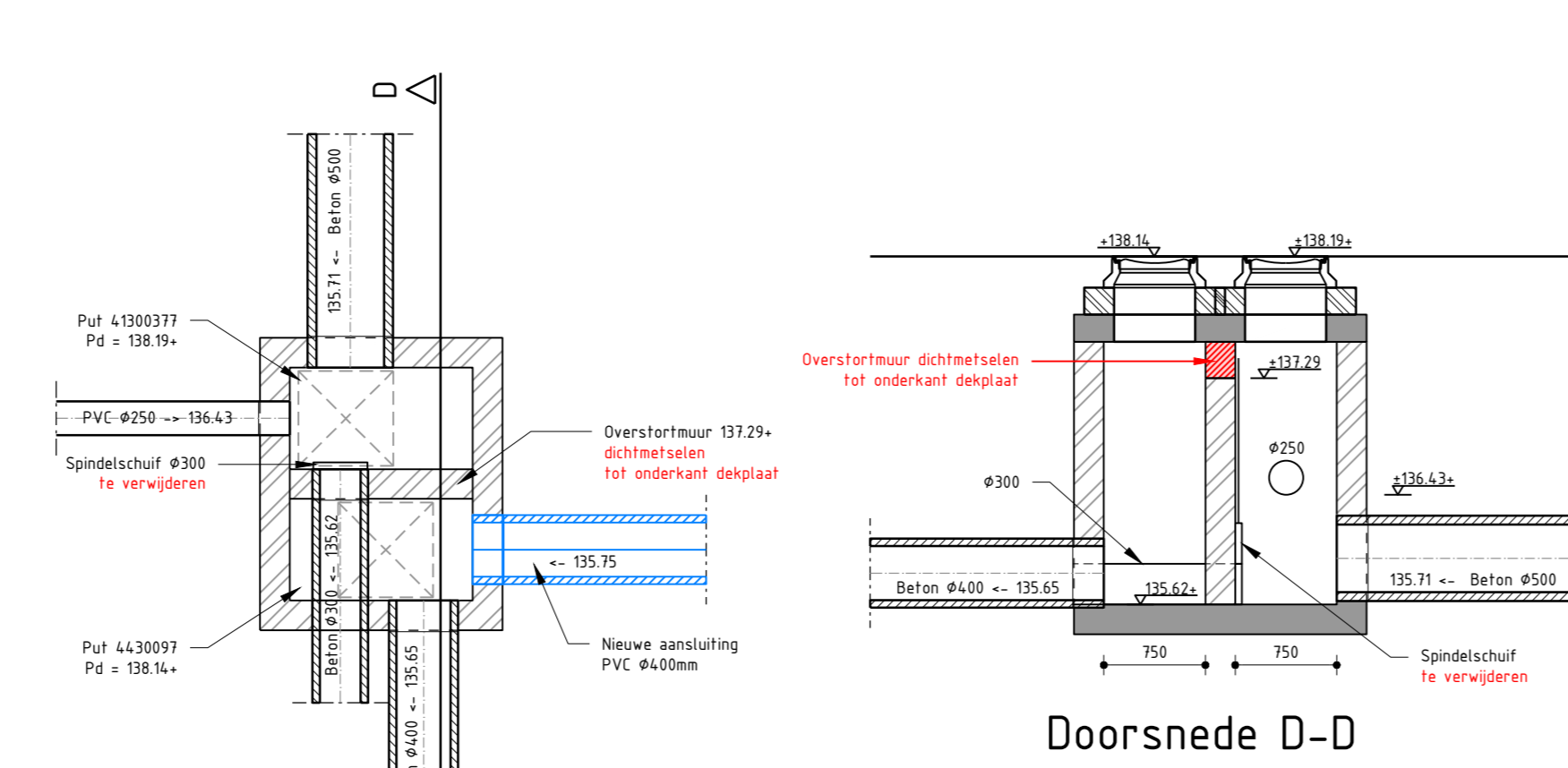

**Doorsnede C1-C1**

**Revisie put 41300377/44300097**  
Schaal 1/50

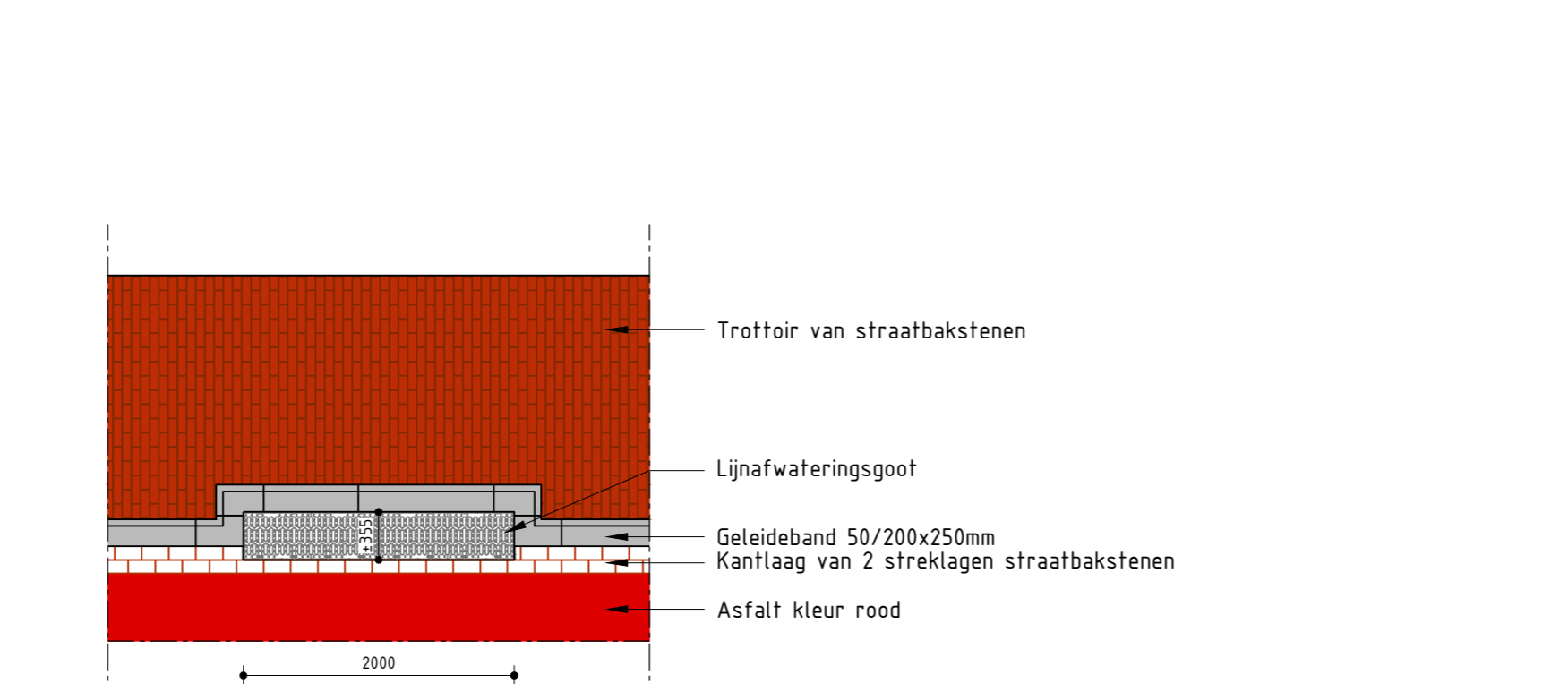

**Doorsnede D-D**

**Principedetail lijnafwatering**  
Schaal 1/50

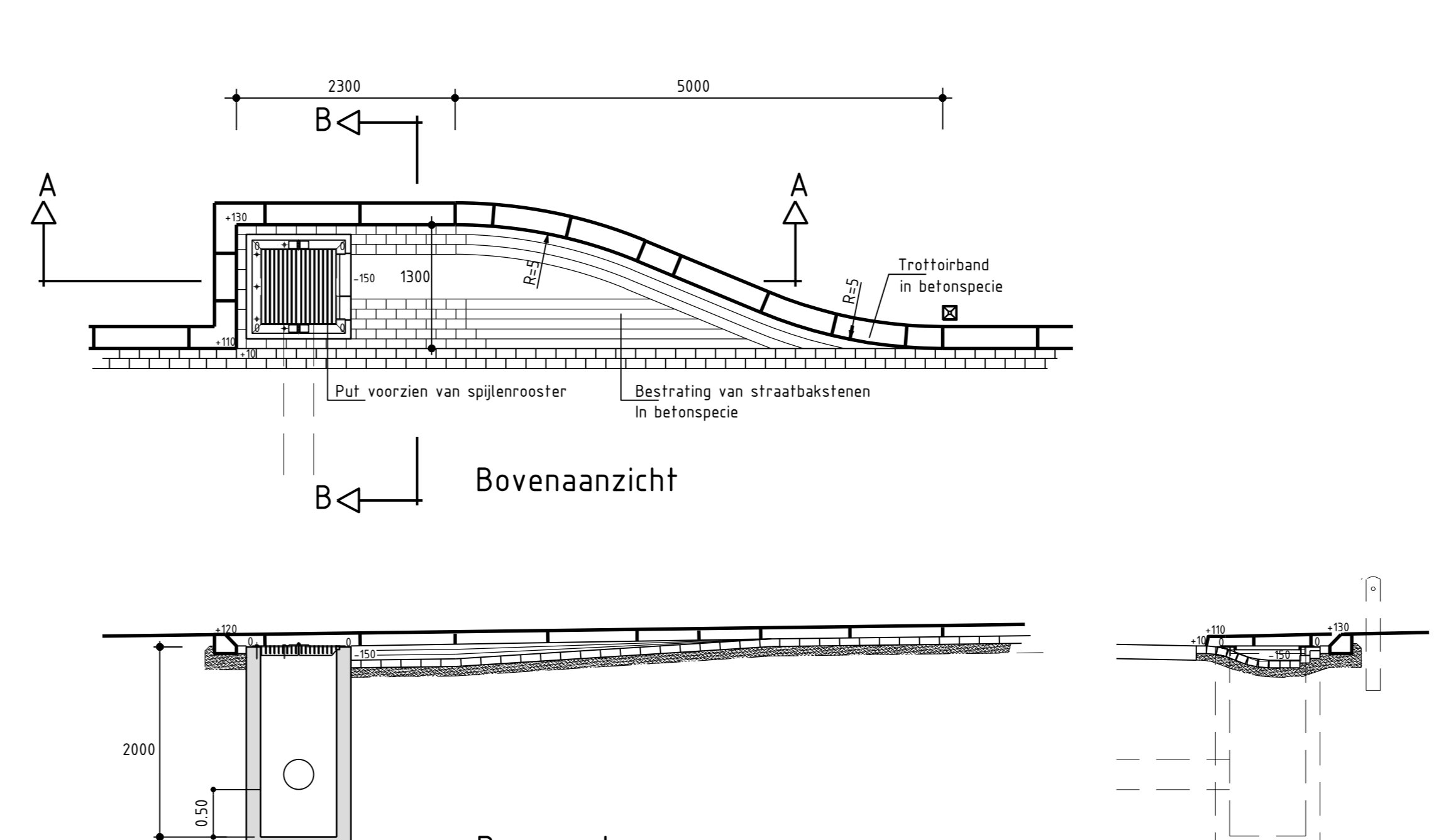

**Bovenaanzicht**

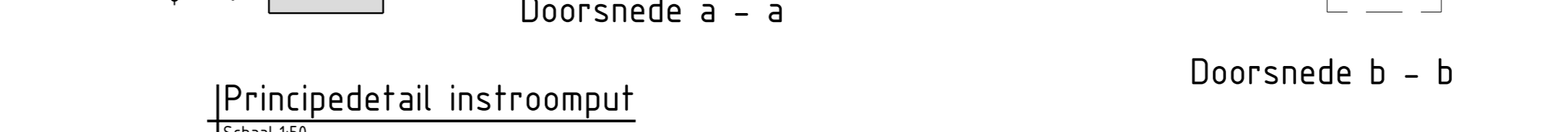

**Doorsnede a - a**



**Principedetail instroomput**  
Schaal 1/50



**Doorsnede b - b**

Revisie	Datum	Omschrijving	Opsteller	Par.	Voorlichter	Par.	Validate	Par.
3	03-09-2019	Behorende bij NVI d.o. 03-09-2019	RJO	JWI	RFE			
2	23-08-2019	Behorende bij bestek d.d. 23-08-2019	RJO	JWI	RFE			
1	28-06-2019	Behorende bij concept bestek d.d. 28-06-2019	RJO	JWI	RFE			
0	25-06-2019		RJO	RFE	RFE			

**Rec. Burg. Wolfsstraat/Bukel te St. Geertruid**

Onderdeel: **Profielen en details**

Opdrachtgever: **Gemeente Eijsden-Margraten**

Fase: **EYS132-0001**

Formaat: **2018-2799**

Schaal: **1:50**

Behorende bij doc. nr.

Projectnummer: **EYS132-0001**

Takennummer: **2018-2799**

Behorende bij doc. nr.

Projectnummer: **088 - 3368333**

Info@kragten.nl

www.kragten.nl

**kragten**