

DWARSPROFIEL A-A
SCHAL 1:100

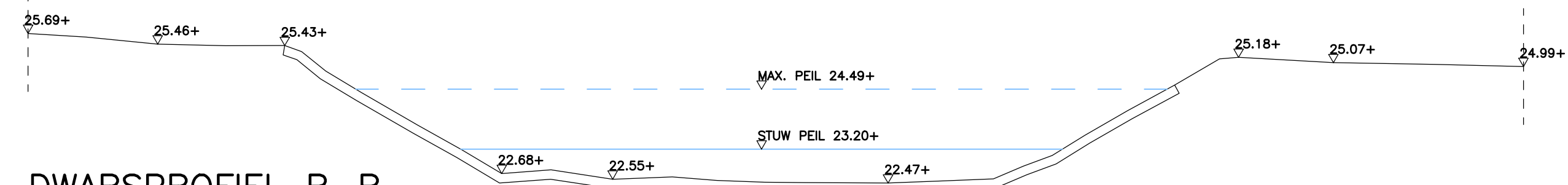

DWARSPROFIEL B-B
SCHAL 1:100

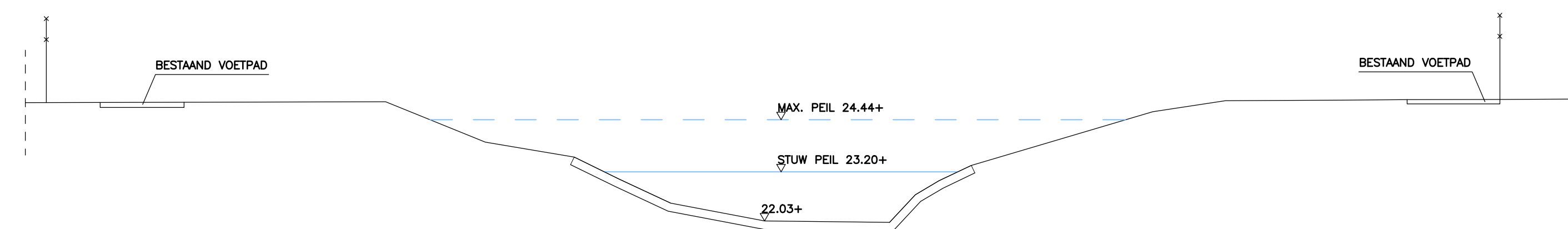

DWARSPROFIEL C-C
SCHAL 1:100

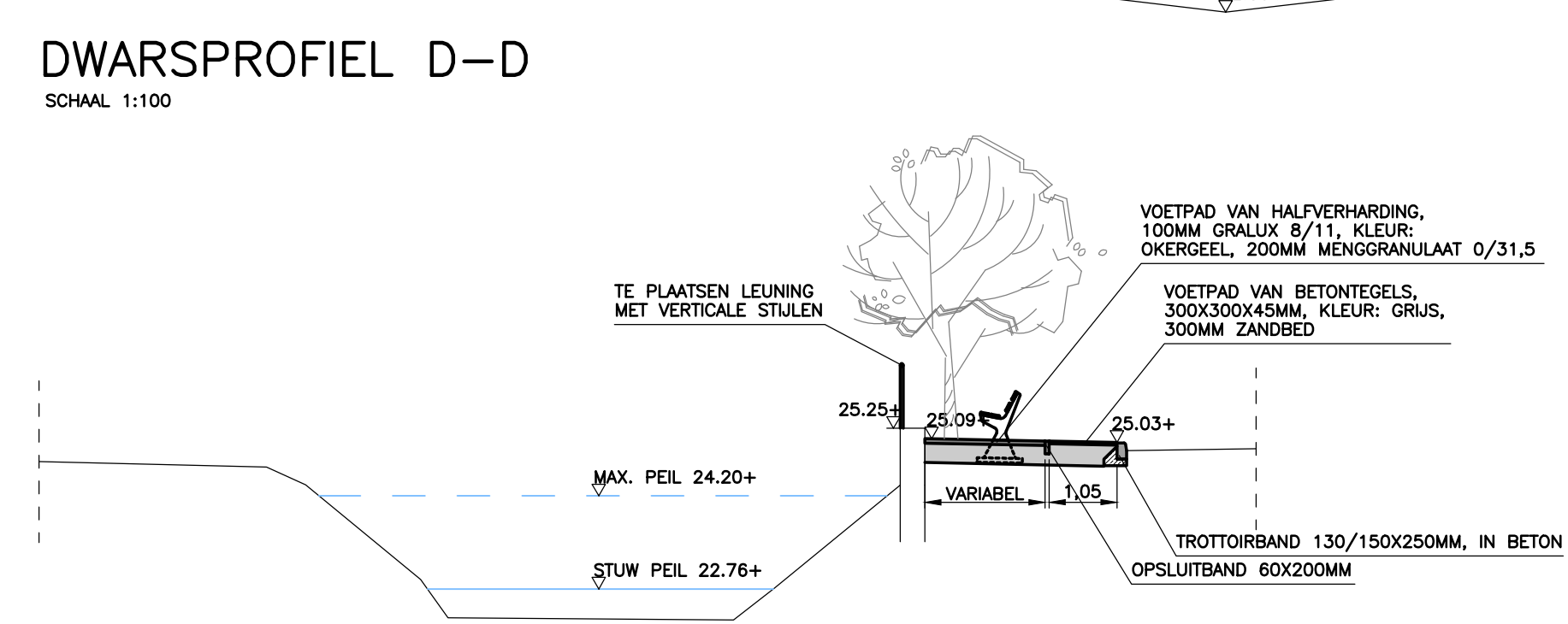

DWARSPROFIEL D-D
SCHAL 1:100

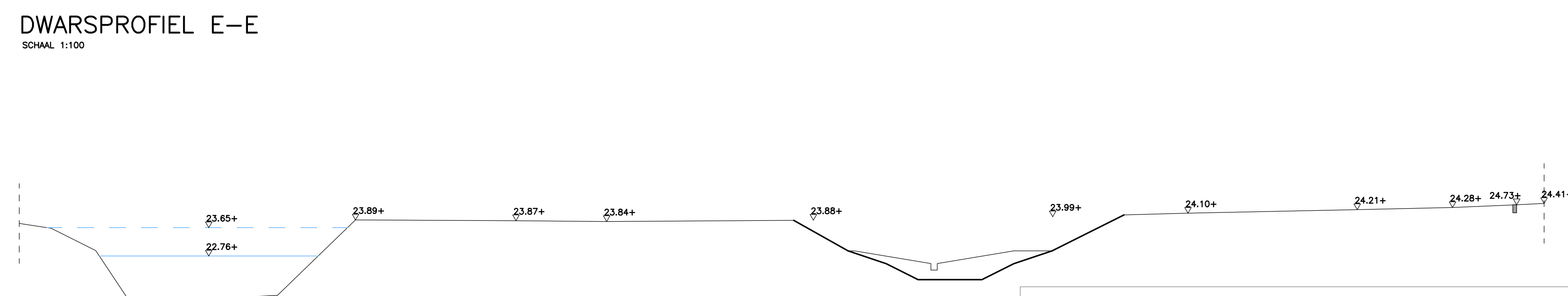

DWARSPROFIEL E-E
SCHAL 1:100



DWARSPROFIEL F-F
SCHAL 1:100

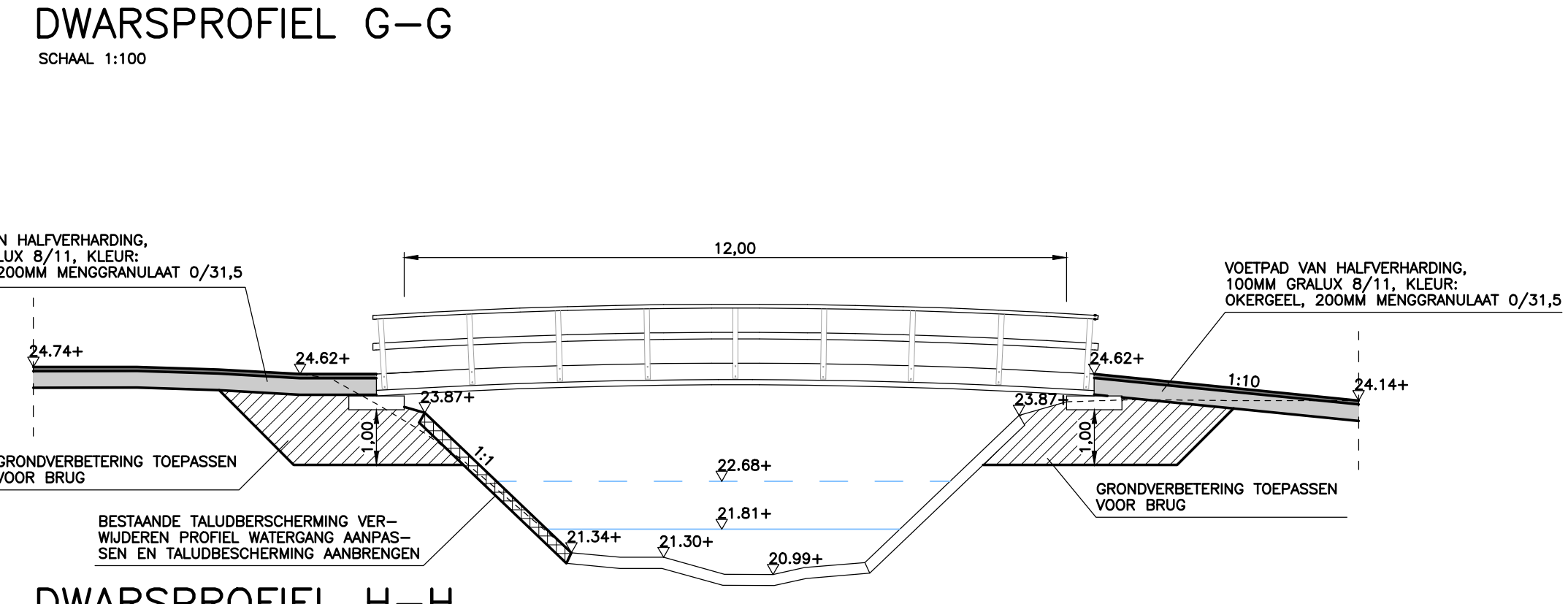

DWARSPROFIEL G-G
SCHAL 1:100



DWARSPROFIEL H-H
SCHAL 1:100

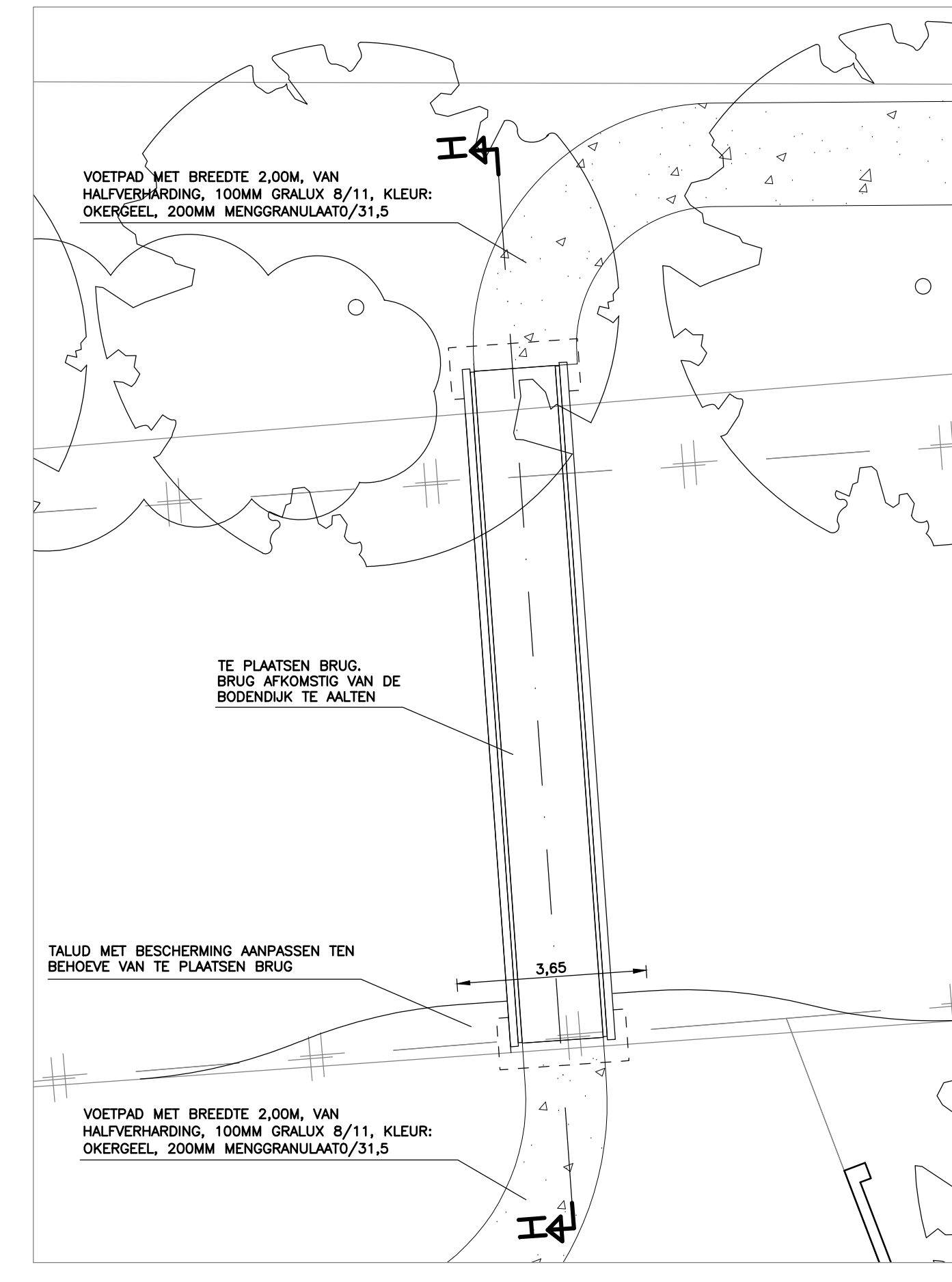

DETAIL BRUG
SCHAL 1:100

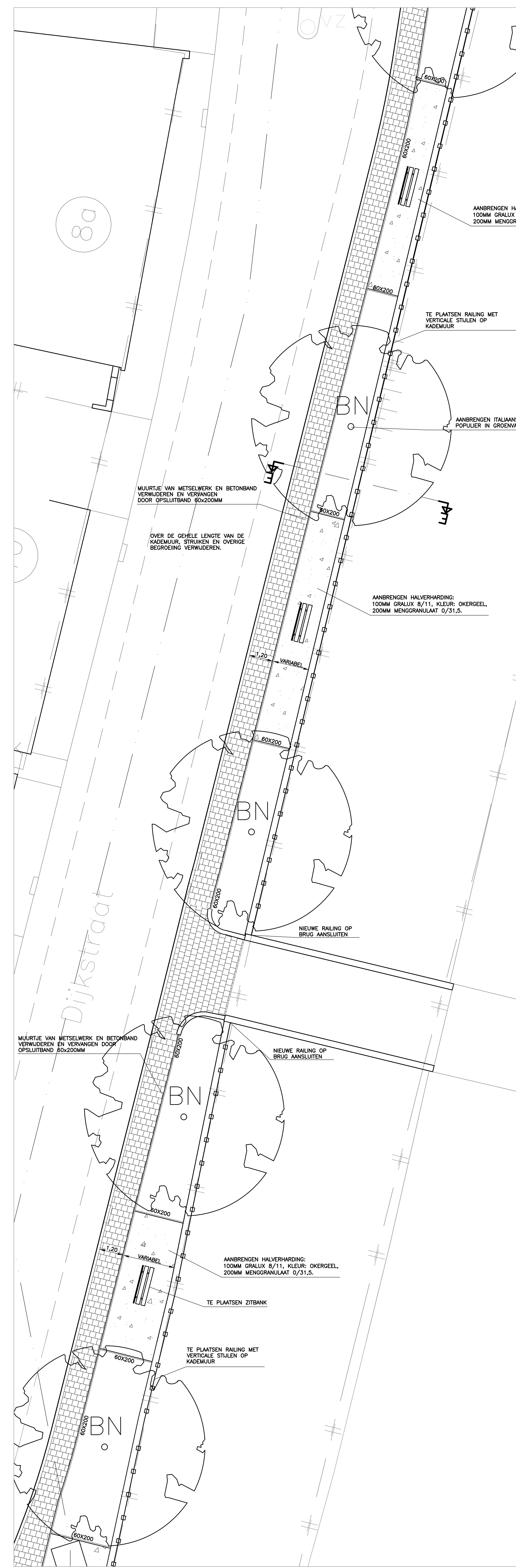

DETAIL KADEMUUR
SCHAL 1:100

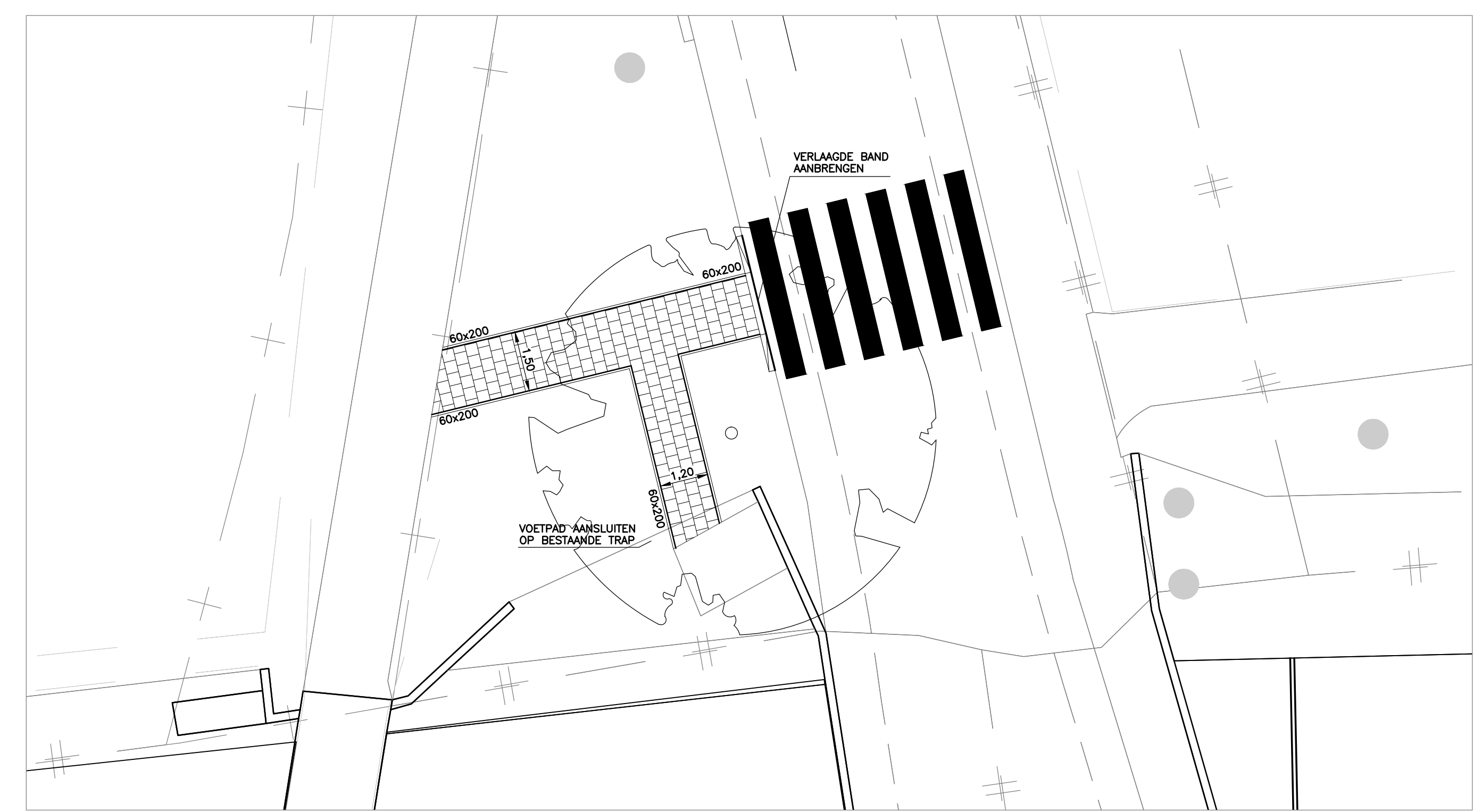

DETAIL VOETPAD EN OVERSTEEK
SCHAL 1:100

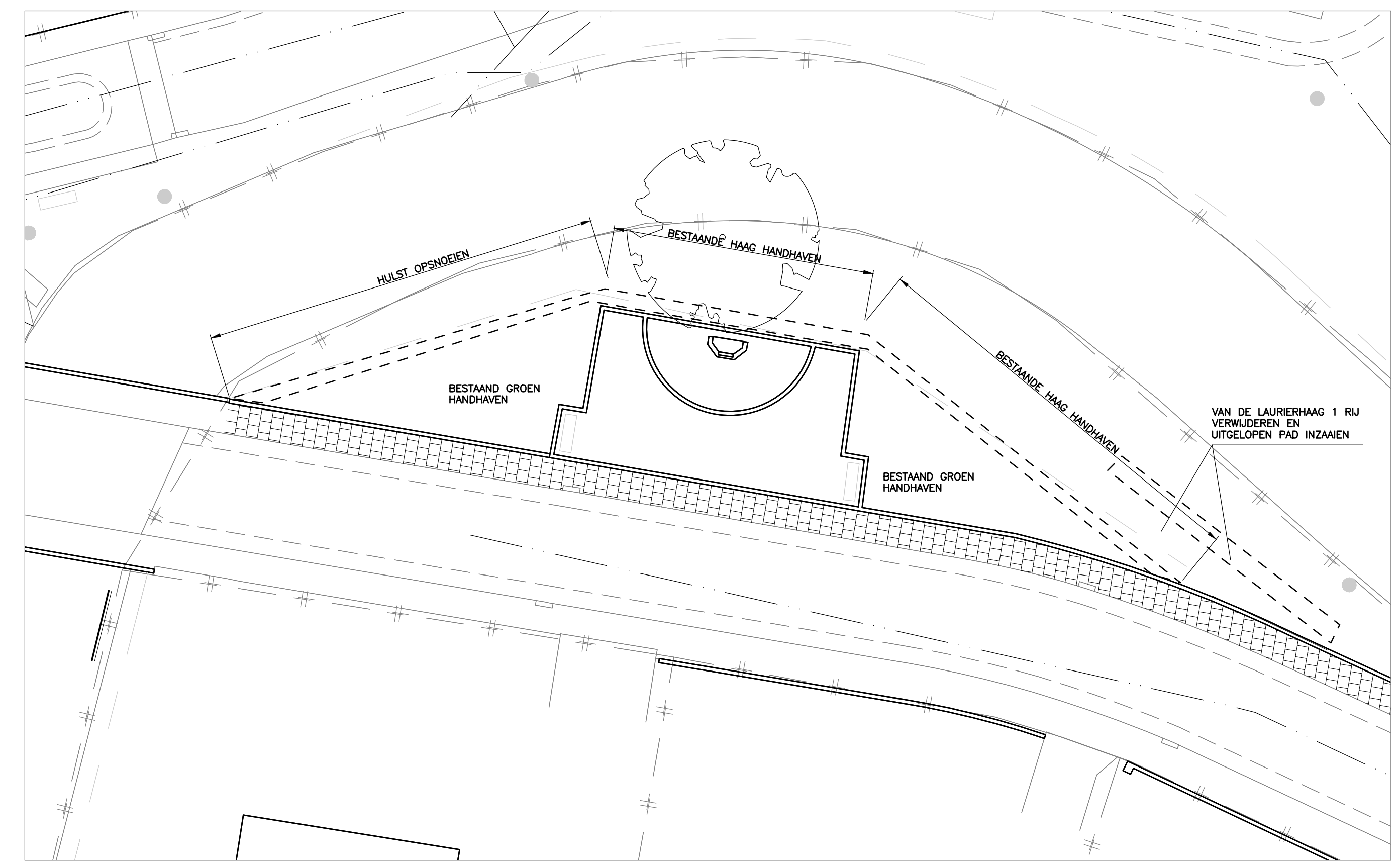

DETAIL MONUMENT
SCHAL 1:200

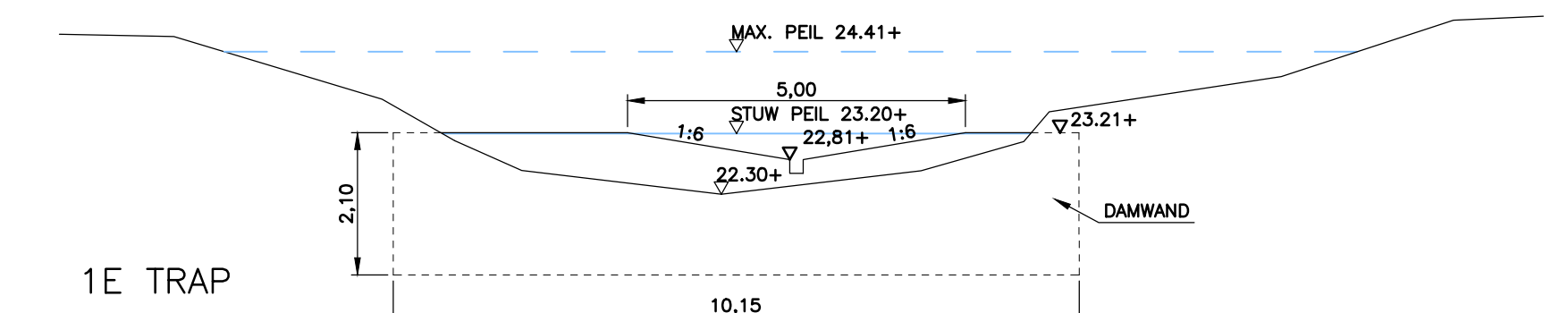

1E TRAP

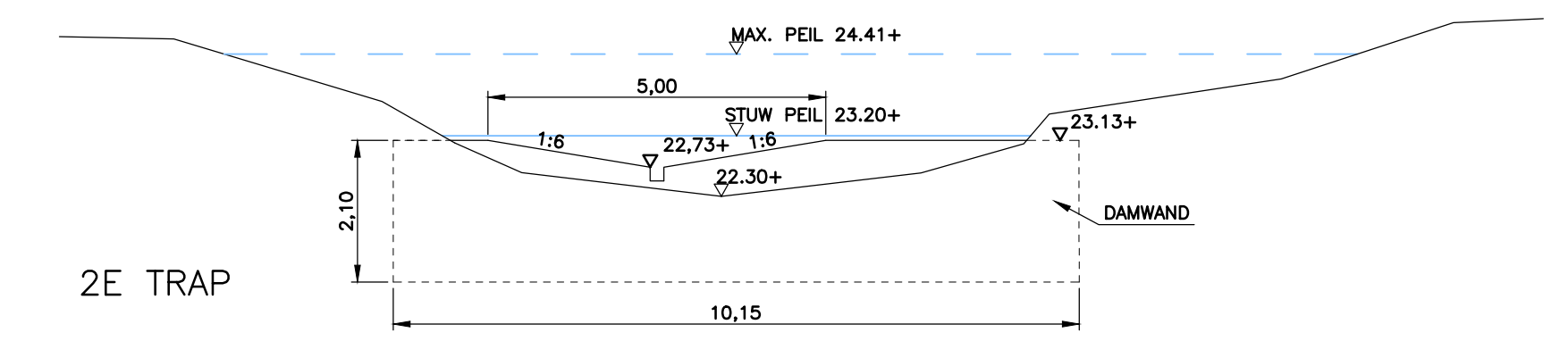

2E TRAP

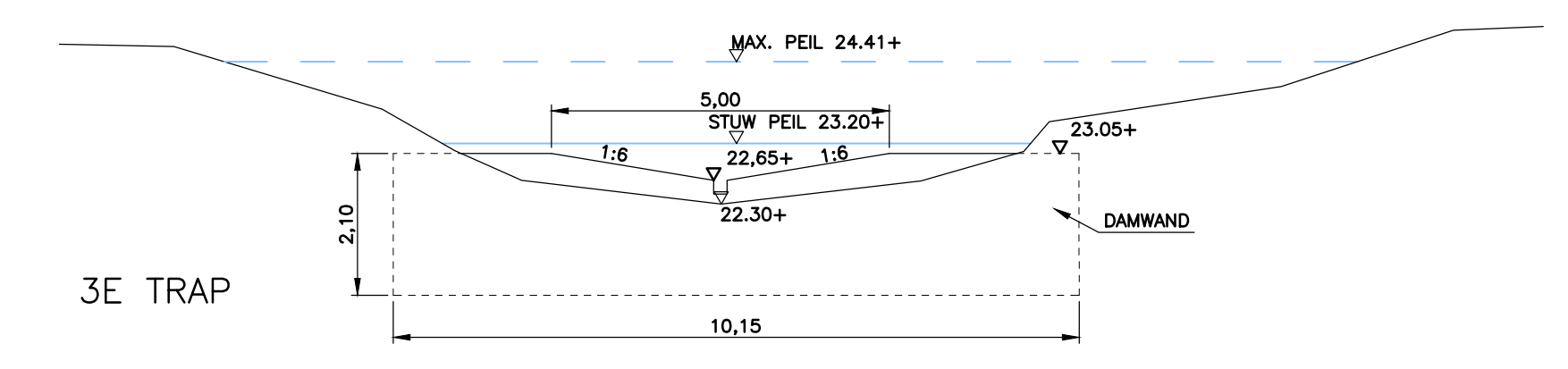

3E TRAP

CASCADE POLBRUG
SCHAL 1:100

		Opdrachtgever Gemeente Aalten	
		Project Greene Slingeplan te Aalten	
Onderdeel Dwarsprofielen en details		Status DO	
Datum: 26-05-2014 Gezien: M. Overbeek Werknummer: DB130101 Formaat: A0 Tekeningnr.:		Datum: _____ Nr: _____ Par: _____ Gekeken: H. ter Woerme Datum: 26-05-2014 Schaal: zie tekening Formaat: A0 Tekeningnr.:	
		B-130101-501	