

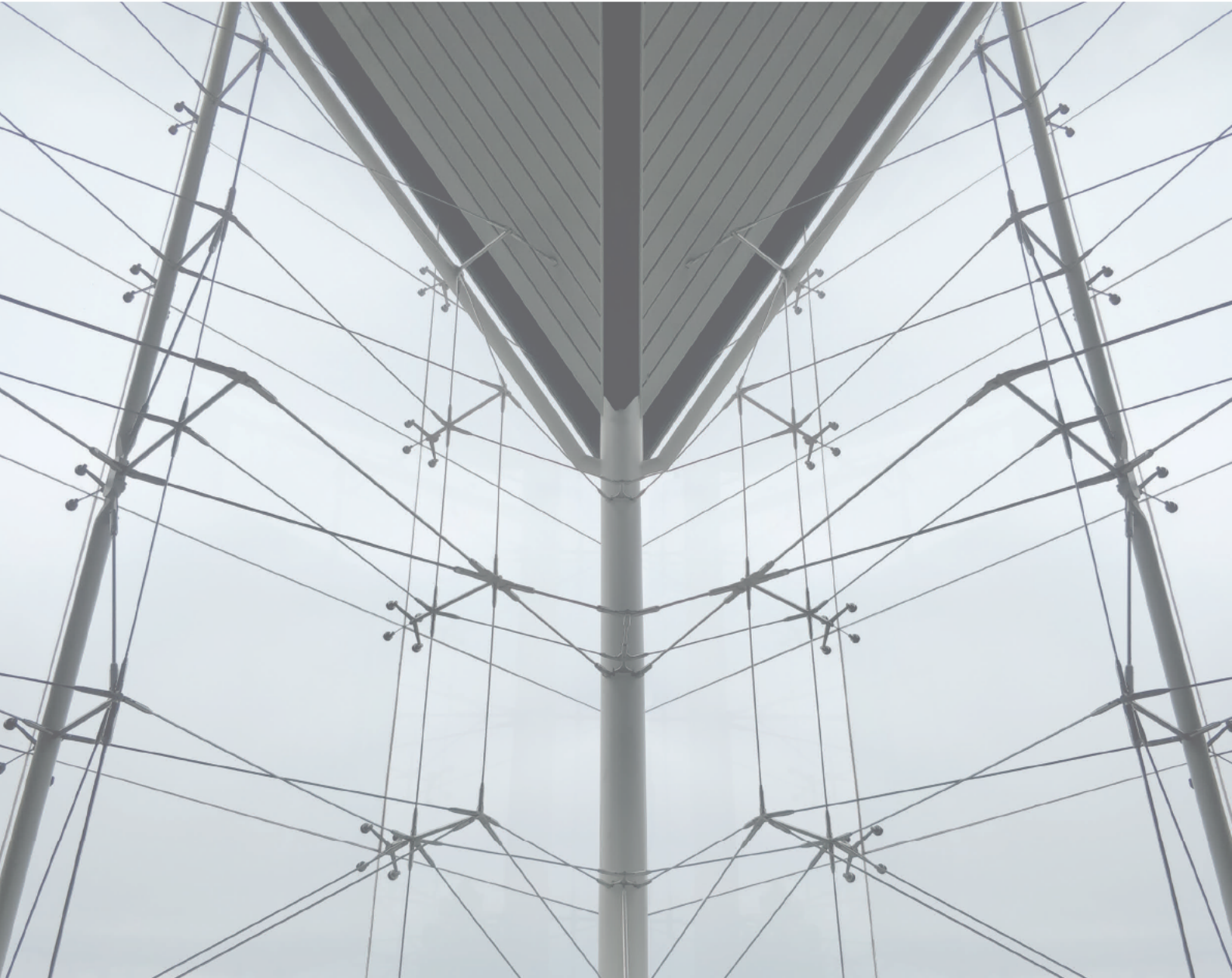

**ADVIESBUREAU
TIELEMANS**

BOUWCONSTRUCTIES B.V.



Itero Brightlandscampus te Geleen

MM20152
15-09-2023

Uitgangspunten
Document_DO-0001



Document MM20152_Document_DO-0001
Project Itero Brighlandscampus te Geleen.

Uitgangspunten

Opdrachtgever Brink Management Advies Eindhoven;Brightlands Chemelot
Campus
Datum 15-09-2023
Revisie A | 18-01-2024
Projectverantwoordelijke
Opgesteld door

Inhoudsopgave

1	Algemeen	6
1.1	Inleiding	6
1.2	Locatie	6
1.3	Gebouwbeschrijving	6
2	Algemene uitgangspunten	7
2.1	Van toepassing zijnde voorschriften	7
2.2	Veiligheidsklasse en referentieperiode	7
2.3	Belastingcombinaties	8
2.3.1	Tabel NB.3 – A1.2(A) — Rekenwaarden van belastingen (EQU) (groep A)	8
2.3.2	Tabel NB.4 – A1.2(B) — Rekenwaarden van belastingen (STR/GEO) (groep B)	8
2.3.3	Tabel NB.7 – A1.3 — Rekenwaarden van buitengewone belastingen	8
2.4	Materialen	9
3	Belastingen	10
3.1	Daken	10
3.2	Vloerbelastingen	10
3.3	Windbelastingen	10
3.4	Sneeuwbelastingen	11
3.5	Overige belastingen	11
4	Brandwerendheid	12
4.1	Algemeen	12
4.2	Eisen geldend voor het project	12
5	Constructieomschrijving	12
5.1	Verticale draagstructuur, stabiliteit en vloeren:	12
5.1.1	Bedrijfshal	12
5.2	Bedrijfsruimte intern	12
5.3	Paalsysteem	13
5.4	Stabiliteit Halconstructie	14
5.4.1	Wind	14
5.5	Stabiliteit Interne ruimte	19
5.6	Fundering	19
5.7	Staalberekening	21

Bijlagen

Bijlage A	Berekening staalconstructie	22
A - 1	Dak berekening	23

A - 2	Facade A	48
A - 3	Facade K	84
A - 4	Facade 1	120
A - 5	Facade 9	132
Bijlage B	Staalberekening connex.....	143
B - 1	Staalberekening connex	144

Documentversies

Revisie 0 (15-09-2023)

Eerste uitgave

Revisie A (18-01-2024)

Opmerkingen RUD verwerkt

1 Algemeen

1.1 Inleiding

Dit document behandelt de uitgangspunten en aannames van de te realiseren bouwconstructie. Hiermee wordt bedoeld heldere informatie over de gedachtegang van Adviesbureau Tielemans bv met betrekking tot het ontwerpen van de hoofddraagconstructie, de stabiliteit, de onderlinge samenhang tussen de verschillende onderdelen en de toegepaste materialen, te geven.

Uitgangspunten ten aanzien van werkzaamheden en proces in de fase Uitvoeringsgereed Ontwerp zijn omschreven in het document *Werkdocument-Uitvoering*.

1.2 Locatie

De geplande nieuwbouwlocatie bevindt zich in de Gemeente Geleen, als hieronder aangegeven in figuur 1-1.

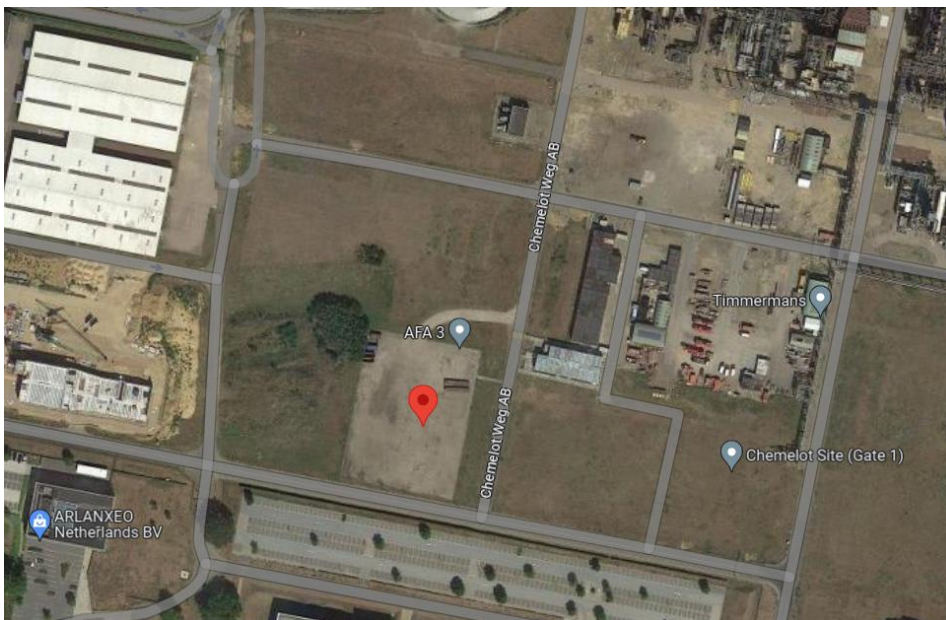

figuur 1-1 Situatie.

1.3 Gebouwbeschrijving

Het gebouw bestaat uit een stalen halconstructie met daarin een bouwerk met 2 verdiepingen en een begane grond. De verdiepingvloeren hebben een kantoorfunctie, opslagfunctie en machine functie.

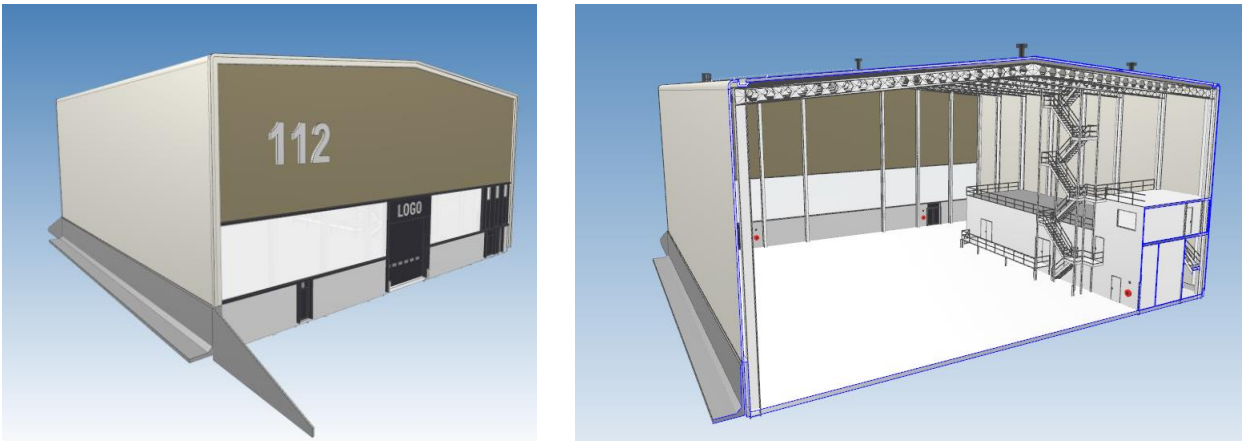

figuur 1-2 Gebouwimpressie.

2 Algemene uitgangspunten

2.1 Van toepassing zijnde voorschriften

Bouwbesluit 2012

NEN 8700	Grondslagen constructieve veiligheid van een bestaand bouwwerk
NEN 8701	Beoordeling van de constructieve veiligheid een bestaand bouwwerk bij verbouwen en afkeuren - Belastingen
NEN-EN 1990:	Grondslagen van het constructief ontwerp
NEN-EN 1991:	Belastingen op constructies
NEN-EN 1992:	Ontwerp en berekening van betonconstructies
NEN-EN 1993:	Ontwerp en berekening van staalconstructies
NEN-EN 1994:	Ontwerp en berekening van staal-betonconstructies
NEN-EN 1995:	Ontwerp en berekening van houtconstructies
NEN-EN 1996:	Ontwerp en berekening van constructies van metselwerk
NEN-EN 1997	Geotechnisch ontwerp
NEN-EN 1999:	Ontwerp en berekening van aluminiumconstructies

2.2 Veiligheidsklasse en referentieperiode

Gebruiksfunctie:	Categorie E: Kantoorfunctie
Gevolklasse:	CC2b
Ontwerplevensduur:	50 jaar
Uitvoeringsklasse staal:	EXC2 conform NEN-EN 1993-1-1 bijlage C.

2.3 Belastingcombinaties

2.3.1 Tabel NB.3 – A1.2(A) — Rekenwaarden van belastingen (EQU) (groep A)

Blijvende en tijdelijke ontwerpsituaties	Blijvende belastingen		Overheersende veranderlijke belasting	Veranderlijke belastingen gelijktijdig met de overheersende	
	Ongunstig	Gunstig		Belangrijkste (indien aanwezig)	Andere
(Vgl. 6.10)	$1,1 G_{k,j,sup}$	$0,9 G_{k,j,inf}$	$1,5 Q_{k,1}$		$1,5 \psi_{0,i} Q_{k,i} (i > 1)$

2.3.2 Tabel NB.4 – A1.2(B) — Rekenwaarden van belastingen (STR/GEO) (groep B)

Blijvende en tijdelijke ontwerpsituaties	Blijvende belastingen		Overheersende veranderlijke belasting	Veranderlijke belastingen gelijktijdig met de overheersende	
	Ongunstig	Gunstig		Belangrijkste (indien aanwezig)	Andere
(Vgl. 6.10a)	$1,35 G_{k,j,sup}^a$	$0,9 G_{k,j,inf}$		$1,5 \psi_{0,1} Q_{k,1}$	$1,5 \psi_{0,i} Q_{k,i} (i > 1)$
(Vgl. 6.10b)	$1,2 G_{k,j,sup}^b$	$0,9 G_{k,j,inf}$	$1,5 Q_{k,1}$		$1,5 \psi_{0,i} K_i (i > 1)$

^c Bij vloeistofdrukken met een fysiek beperkte waarde mag zijn volstaan met $1,2 G_{k,j,sup}$.
^d Deze waarde is berekend met $\xi = 0,89$.

Het onderscheid tussen gunstig en ongunstig werkende blijvende belasting hoeft bij STR/GEO alleen te worden gemaakt voor het totaal van alle belasting van een soort, zoals eigengewicht.

Opmerking;

Voor gevolgklasse 2 geldt $K_{FI} = 1$ en kunnen voor de partiële factoren de waarden in tabel NB.4 - A1.2(B) worden gebruikt. Voor gevolgklasse 1 geldt volgens tabel B3 $K_{FI} = 0,9$; voor gevolgklasse 3 geldt $K_{FI} = 1,1$.

2.3.3 Tabel NB.7 – A1.3 — Rekenwaarden van buitengewone belastingen

Ontwerpsituaties	Blijvende belastingen		Overheersende buitengewone of aardbevingsbelasting	Veranderlijke belastingen gelijktijdig met de overheersende	
	Ongunstig	Gunstig		Belangrijkste (indien aanwezig)	Andere
Buitengewoon (Vgl. 6.11a/b)	$1,00 \cdot G_{k,j,sup}^a$	$1,00 \cdot G_{k,j,inf}$	$1,00 \cdot A_d$	$\psi_{1,1} Q_{k,1}^a$	$\psi_{2,i} Q_{k,i} (i > 1)$
Aardbeving (Vgl. 6.12a/b)	$1,00 \cdot G_{k,j,sup}^b$	$1,00 \cdot G_{k,j,inf}$	$1,00 \cdot A_{ek}$ of $1,00 \cdot A_{Ed}$	$\Psi_{2,1} Q_{k,1}$	$\psi_{2,i} Q_{k,i} (i > 1)$

^a Uitsluitend voor wind in combinatie met brand bij het beoordelen van disproportionele schade volgens NEN-EN 1991-1-7; voor overige gevallen $\psi_{2,1}$.

2.4 Materialen

Funderingspalen	Sterkteklasse: C30/37	Milieuklasse: XC4
Fundering	Sterkteklasse: C30/37	Milieuklasse: XC3; XF1
Kelderbuitenwanden	Sterkteklasse: C30/37	Milieuklasse: XC3; XF1
Gevels binnenblad	Sterkteklasse: C30/37	Milieuklasse: XC3
Gevels buitenblad	Sterkteklasse: C30/37	Milieuklasse: XC4; XF1
Situbeton binnen	Sterkteklasse: C25/30	Milieuklasse: XC1
Situbeton buiten	Sterkteklasse: C30/37	Milieuklasse: XC4; XF1
Drukragen	Sterkteklasse: C25/30	Milieuklasse: XC1
Prefabbeton overig	Sterkteklasse: \geq C35/45	Milieuklasse: XC1
Zwembadwanden	Sterkteklasse: C30/37	Milieuklasse: XC3; XD2
Bedrijfsverhardingen	Sterkteklasse: C35/45	Milieuklasse: XC4; XD3; XF4; XA2
Bedrijfsvloeren chemicaliën	Sterkteklasse: C30/37	Milieuklasse: XC3; XA2
Bedrijfsvloeren productie	Sterkteklasse: C30/37	Milieuklasse: XC3; XA1
Dockboards	Sterkteklasse: C35/45	Milieuklasse: XC4; XD3; XF2; XA2
Keerwanden	Sterkteklasse: C35/45	Milieuklasse: XC4; XD3; XF2; XA2
Vloeistofdichte vloer	Sterkteklasse: C35/45	Milieuklasse: XC4; XD3; XF2; XA2
Wapening	losse staven	B500 B
	wapeningsnetten	B500 A
Walsprofielen	S235JRG2 / S355J2G3	
Buisprofielen	S355J2H	
Kalkzandsteen	Steendruksterkte 20,00 N/mm ²	Mortel (M5 / M10 / M15 /) lijm mortel
Baksteen	Steendruksterkte 15,00 N/mm ²	Mortel (M5 /) M10 (/ M15 / lijm mortel)
Hout	Sterkteklasse: C24	
Gelamineerd hout	Sterkteklasse: GL24h	

Tenzij anders op tekeningen of in berekeningen vermeld.

3 Belastingen

3.1 Daken

Dakconstructie halconstructie	Categorie H: Daken		
Dak + dakbedekking			0,15 = 0,15
Zonnepanelen			0,25 = 0,25
			+ -----
Totaal blijvende belasting			0,40 kN/m ²
Opgelegde belasting op 10 m ²			1,00 = 1,00 kN/m ²
Geconcentreerde opgelegde belasting			1,50 kN
Momentaanfactor	$\psi_0 = 0,00$	$\psi_1 = 0,00$	$\psi_2 = 0,00$
Reductiefactor			1,00

3.2 Vloerbelastingen

2de verdiepingvloer	Categorie B: Kantoorfunctie		
Eigengewicht			71x221x1000x7,5e-9x1/0,6 = 0,20
Afwerking			18x1000x1000x7,5E-9 = 0,14
Plafond, leidingen etc			0,25 = 0,25
			+ -----
Totaal blijvende belasting			0,58 kN/m ²
Opgelegde belasting inclusief scheidingswanden			2,50 kN/m ²
Geconcentreerde opgelegde belasting			7,00 kN
Momentaanfactor	$\psi_0 = 1,00$	$\psi_1 = 0,90$	$\psi_2 = 0,80$
Reductiefactor			1,00
1-ste verdiepingvloer mezzanine	Categorie E: Opslag- of industriefunctie		
Kanaalplaat WX500			5,3/1,2+0,219/1,2 = 4,60
Afwerking			0,07x20 = 1,40
Plafond, leidingen etc			0,20 = 0,20
			+ -----
Totaal blijvende belasting			6,20 kN/m ²
Opgelegde belasting			20,00 kN/m ²
Geconcentreerde opgelegde belasting			7,00 kN
Momentaanfactor	$\psi_0 = 1,00$	$\psi_1 = 0,90$	$\psi_2 = 0,80$
Reductiefactor			1,00
1-ste verdieping Technische ruimte	Categorie E: Opslag- of industriefunctie		
Cornflor 210-1,0 h=280			3,05 = 3,05
Afwerking			0,05x20 = 1,00
			+ -----
Totaal blijvende belasting			4,05 kN/m ²
Opgelegde belasting			10,00 kN/m ²
Geconcentreerde opgelegde belasting			7,00 kN
Momentaanfactor	$\psi_0 = 1,00$	$\psi_1 = 0,90$	$\psi_2 = 0,80$
Reductiefactor			1,00

3.3 Windbelastingen

Windbelastingen worden bepaald conform NEN-EN 1991-1-4.

Referentiehoogte: 20,0m

Windgebied: III

Terreincategorie: Onbebouwd

3.3.1.1 Stuwdruk:

Stuwdruk =20,00m +maaiveld	Windbelasting		
Windgebied III; Onbebouwd; hoogte 20,000 boven maaiveld, stuwdruk = 0,88 kN/m ²			
Momentaanfactor	$\psi_0 = 0,00$	$\psi_1 = 0,20$	$\psi_2 = 0,00$
Reductiefactor			1,00

De windbelastingen die volgen uit de resultanten van de stuwdrukken worden in vervolgdOCUMENTEN berekend.

3.4 Sneeuwbelastingen

Sneeuwbelastingen worden bepaald conform NEN-EN 1991-1-3.

Voor de platte daken geldt een sneeuwbelasting van 0,56 kN/m².

Eventuele sneeuwophopingen bij opgaande gevels of obstakels worden in vervolgdOCUMENTEN beschouwd.

3.5 Overige belastingen

Trappen	Categorie E: Opslag- of industriefunctie		
Eigengewicht		0,5 =	0,50
		+	-----
Totaal blijvende belasting			0,50 kN/m ²
Opgelegde belasting		4 =	4,00 kN/m ²
Geconcentreerde opgelegde belasting			7,00 kN
Momentaanfactor	$\psi_0 = 1,00$	$\psi_1 = 0,90$	$\psi_2 = 0,80$
Reductiefactor			1,00

4 Brandwerendheid

4.1 Algemeen

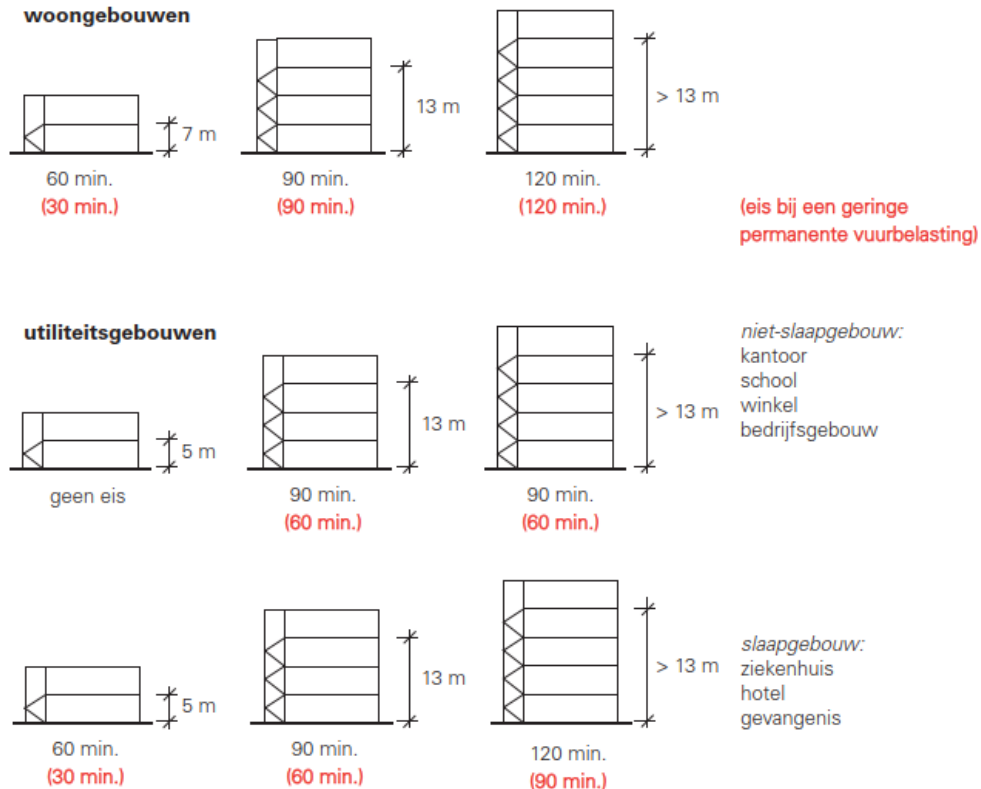

figuur 4-1 Eisen aan de hoofdraagconstructie van woongebouwen en van utiliteitsgebouwen. Bepalend is de ligging van de vloer van het hoogste verblijfgebied. In rood staan de eisen bij een permanente vuurbelasting van minder dan 500 MJ/m².

4.2 Eisen geldend voor het project.

Voor dit project wordt aan de brandwerendheidseis voldaan door het plaatsen van een brandwerend scherm aan de Zuidgevel. Dit scherm zorgt voor een brandwerendheid van buiten naar binnen à 60 minuten. Daarnaast wordt er op de staalconstructie een brandwerende coating aangebracht. Beide voorzieningen zullen er samen voor zorgen dat er aan eisen met betrekking tot brandwerendheid wordt voldaan.

Er wordt gekozen om de om voor de noordgevel in as 1 een 60min. WBDBO te waarborgen.

5 Constructieomschrijving

5.1 Verticale draagstructuur, stabiliteit en vloeren:

5.1.1 Bedrijfshal

Stalen kolommen, zie bijlage A voor beschrijving doormiddel van een ontwerpberekening door IBV structu-res, d.d. 03-07-2022.

5.2 Bedrijfsruimte intern

Interne bedrijfsruimte (mezaninevloeren) uitvoeren met een stalen kolommen en liggers, zie figuur 5-1.

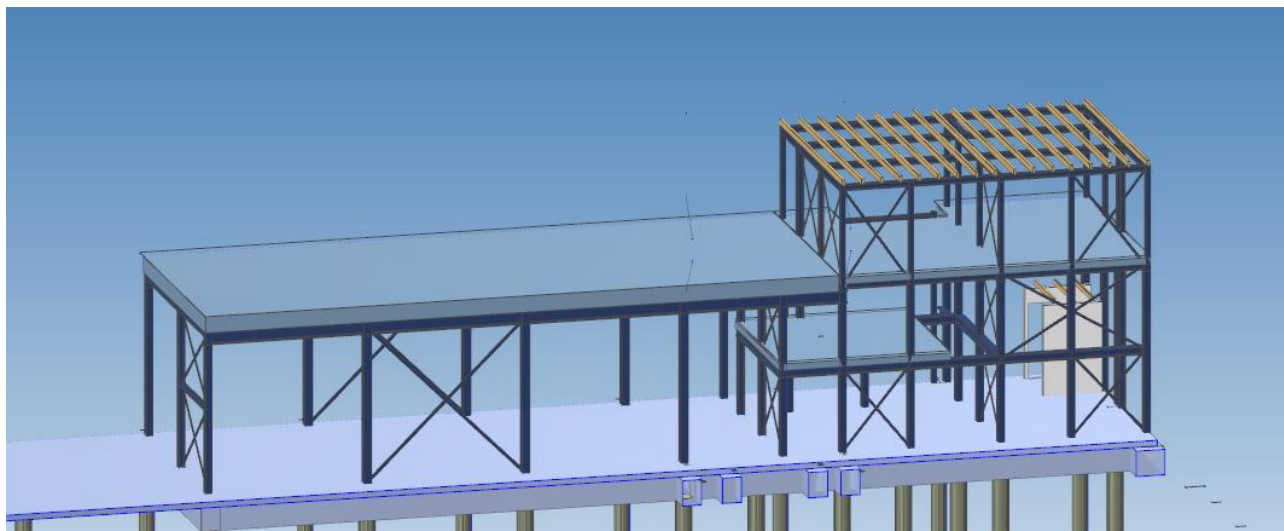

figuur 5-1 Staalconstructie interne bedrijfsruimte

5.3 Paalsysteem

Conform advies Inpijnblokpoel met rapportnummer 23ZP1421 is er gekozen voor mortelschroefpalen rond 500mm, inheidiepte -14500mm.

5.4 Stabiliteit Halconstructie

Deze berekening worden gebruikt voor de reactiekrachten op de fundering te bepalen, zie de berekening van IBV structures (bijlage B) voor de profieltoetsing.

Stabiliteit te verzorgen door stabiliteitsverbanden als weergegeven in figuur 5-2:

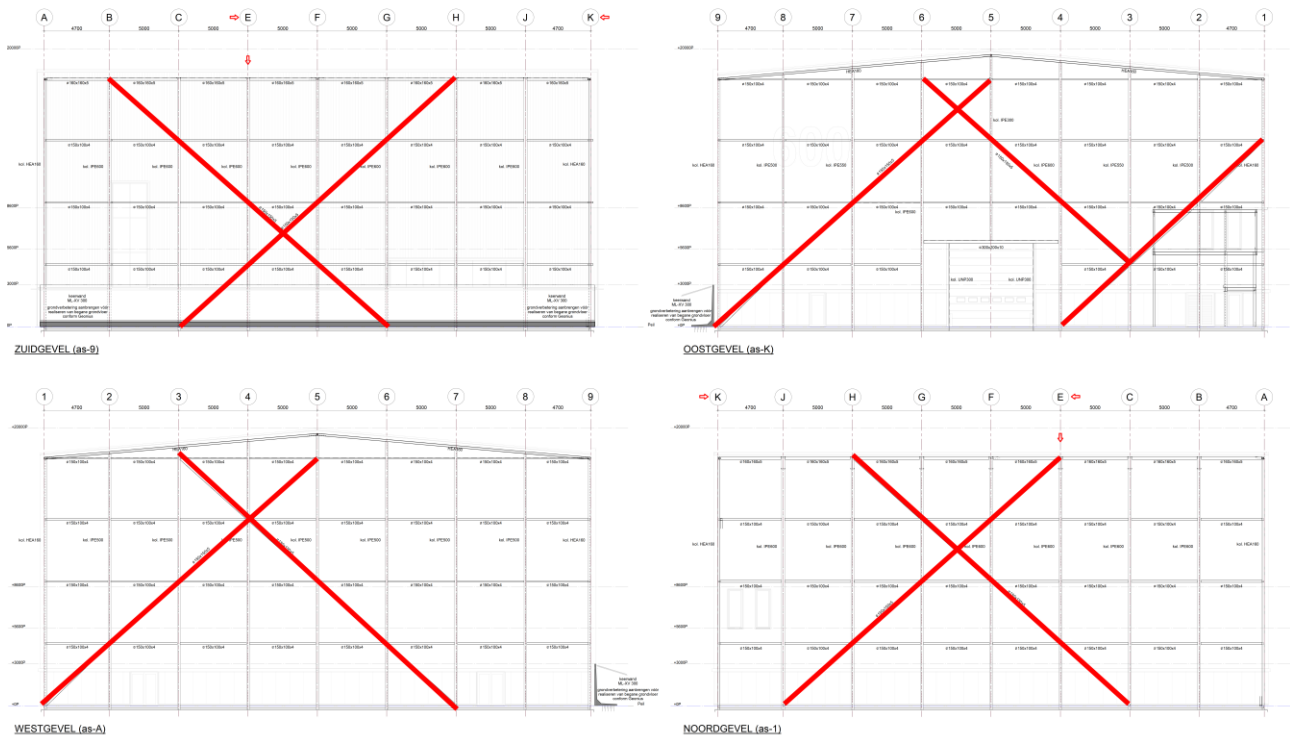

figuur 5-2 Stabiliteitsverbanden halconstructie

5.4.1 Wind

Figuur 5-3 toont de dimensies van de bouwdelen en de primaire windrichtingen.

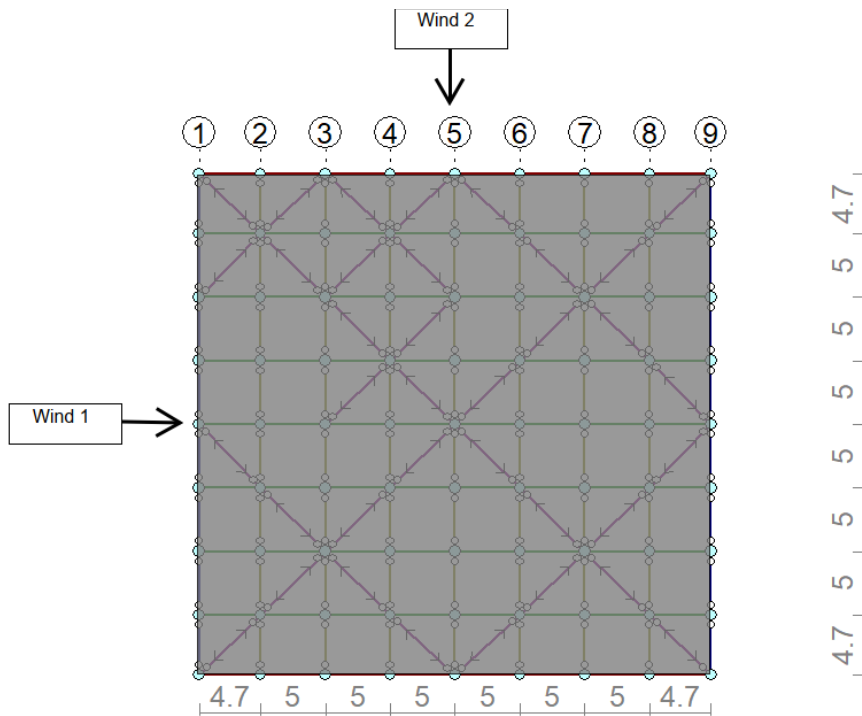

figuur 5-3 Overzicht primaire windrichtingen.

5.4.1.1 Wind 1

De stabiliteitselementen voor wind 1 zitten op as A en as K. De windbelasting op gevel A en K wordt berekend met Technosoft Raamwerken. De bijdrage van de windverbanden in het dak en de wrijving worden toegevoegd als puntlasten.

Wind 1

		$G_k + \psi_0 \times \psi_t \cdot Q_k$	pb	vb
F(B-J)	$((39,4-4,7) \times 9,75 \times 0,88 \times (0,8 + 0,5) \times 0,85) / 7 \times ($	$0,00 + 1,00 \times 1,00$	$) = 0,00 +$	$47,00 \text{ extr}$
Wrijving	$39,4 \times 39,4 \times 0,88 \times 0,01 / 7 \times ($	$0,00 + 1,00 \times 1,00$	$) = 0,00 +$	$1,95 \text{ extr}$
			$+ \text{-----} + \text{-----}$	
		Totaal	$0,00 +$	$48,95 \text{ kN}$

Frequent = 9,40 kN Quasi blijvend = 0,00 kN Momentaan = 0,00 kN Extreem = 48,95 kN

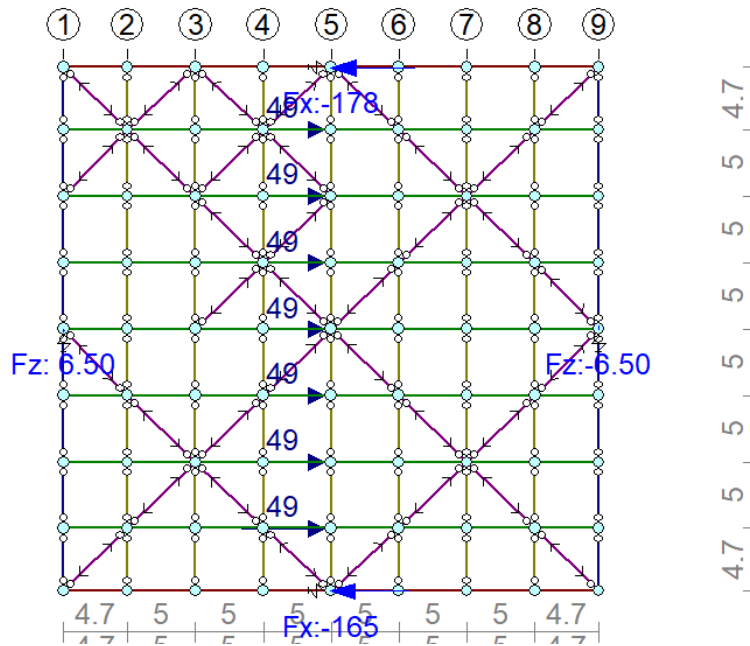

figuur 5-4 Reactiekrachten van wind 1

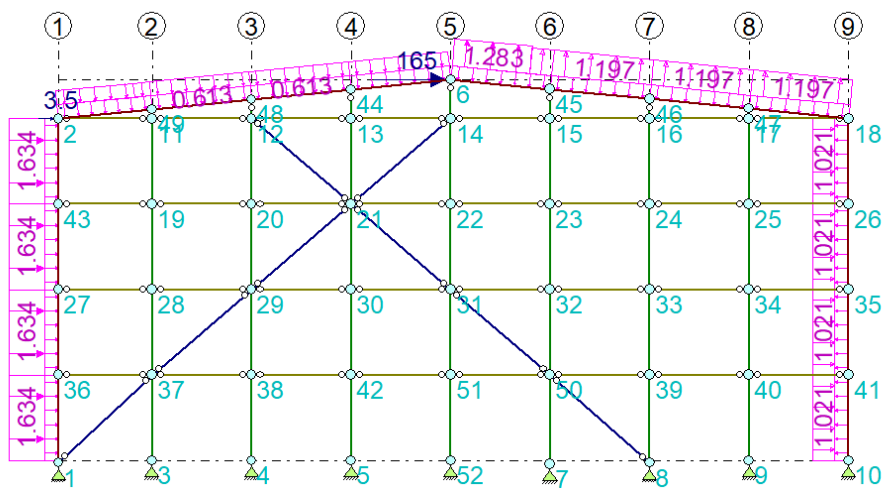

figuur 5-5 Windbelasting op as .A

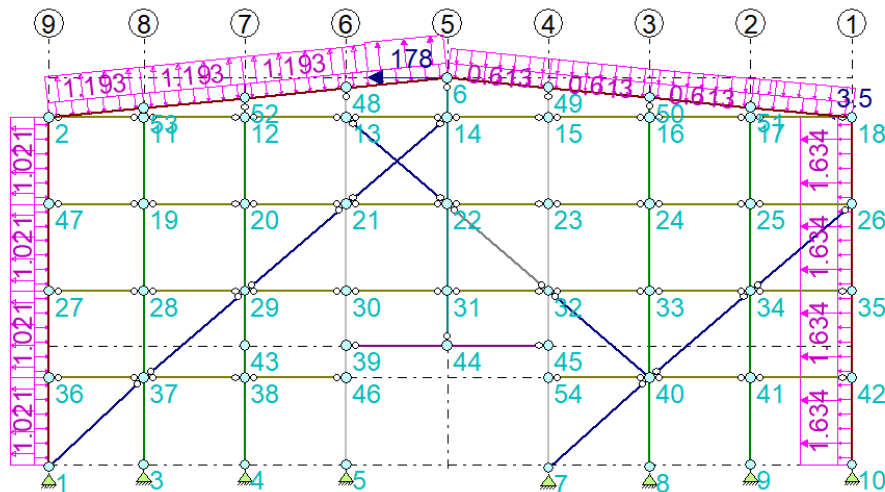

figuur 5-6 Windbelasting op as K.

Voor de berekening zie bijlage A-1 t/m A-3.

5.4.1.2 Wind 2

De stabiliteitselementen voor wind 2 zitten op as 1 en as 9.

Wind 2

		$G_k + \psi_0 \times \psi_t \cdot Q_k$	pb	vb
F1/9	$2,4 \times 9,75 \times 0,88 \times (0,8 + 0,3) \times 0,85 \times ($	$0,00 + 1,00 \times 1,00) =$	$0,00 +$	19,25
F2/8	$4,85 \times 9,75 \times 0,88 \times (0,8 + 0,3) \times 0,85 \times ($	$0,00 + 1,00 \times 1,00) =$	$0,00 +$	38,91
F3-7	$5 \times 9,75 \times 0,88 \times (0,8 + 0,3) \times 0,85 \times ($	$0,00 + 1,00 \times 1,00) =$	$0,00 +$	40,11
F1/9	$2,4 \times 9,75 \times 0,88 \times (0,5 - 0,3) \times 0,85 \times ($	$0,00 + 1,00 \times 1,00) =$	$0,00 +$	3,50
F2/8	$4,85 \times 9,75 \times 0,88 \times (0,5 - 0,3) \times 0,85 \times ($	$0,00 + 1,00 \times 1,00) =$	$0,00 +$	7,07
F3-7	$5 \times 9,75 \times 0,88 \times (0,5 - 0,3) \times 0,85 \times ($	$0,00 + 1,00 \times 1,00) =$	$0,00 +$	7,29
Wrijving	$39,4 \times 39,4 \times 0,88 \times 0,01 / 9 \times ($	$0,00 + 1,00 \times 1,00) =$	$0,00 +$	1,52

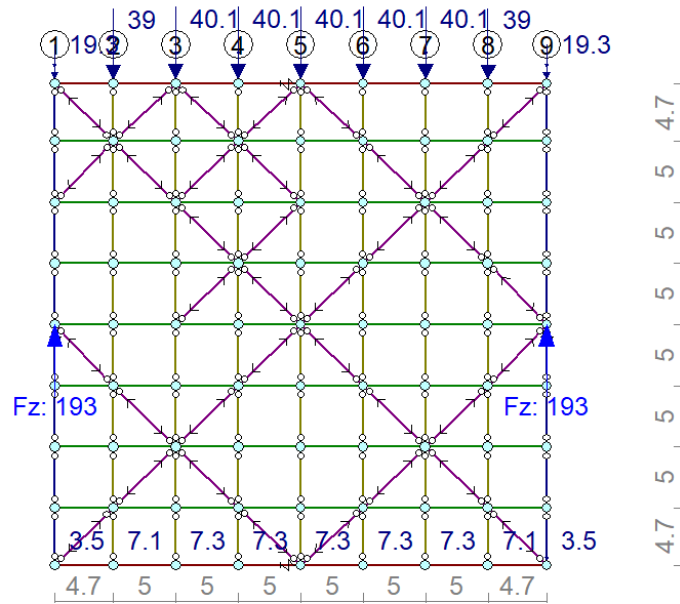

figuur 5-7 Reactiekrachten van wind 1

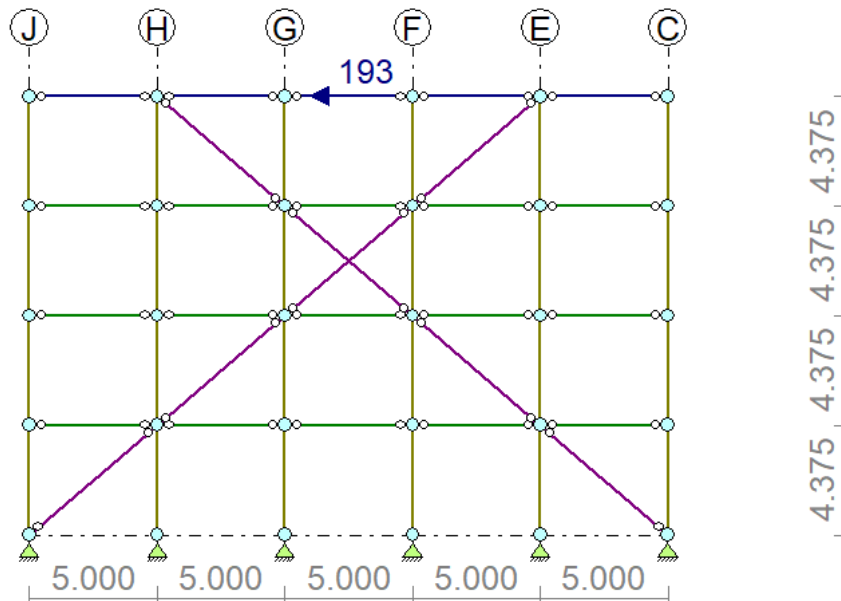

figuur 5-8 Windbelasting op as 1.

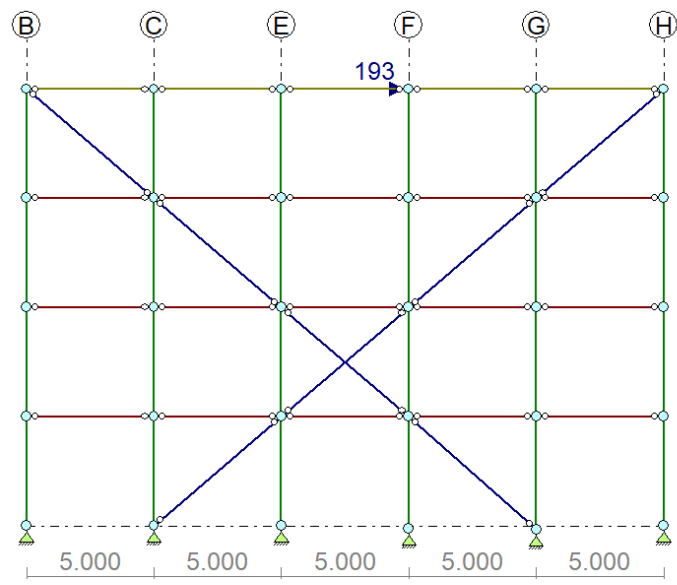

figuur 5-9 Windbelasting op as 9.

Voor de berekeningen zie bijlage A-4 en A-5.

5.5 Stabiliteit Interne ruimte

Stabiliteit te verzorgen door stabiliteitsverbanden als weergegeven in

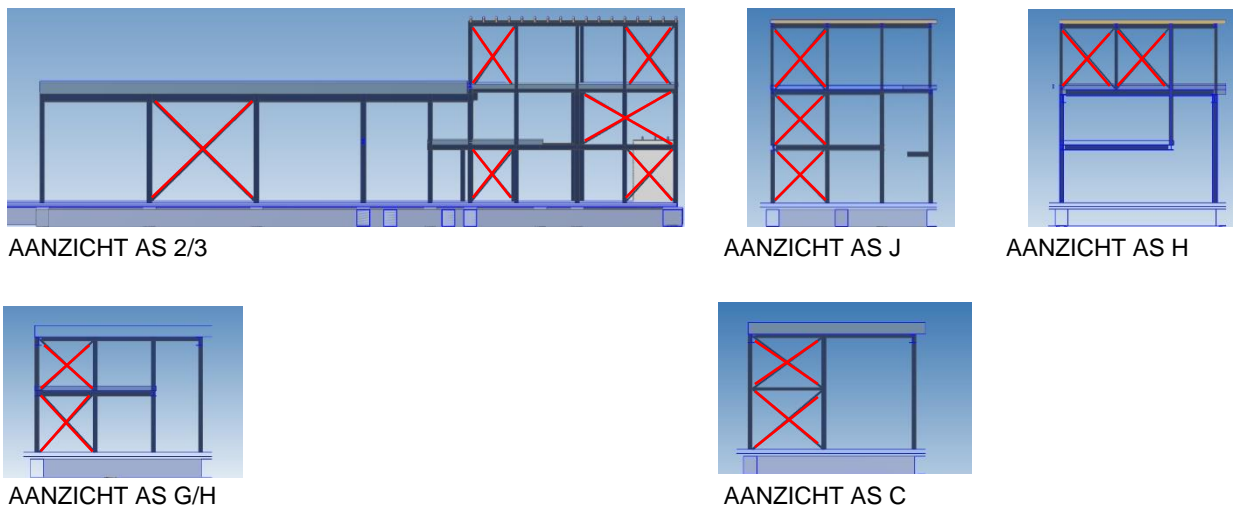

figuur 5-9 Stabiliteitsverbanden interne bedrijfsruimte

5.6 Fundering

Fundering uit te voeren met balken 900x600, loodrecht op de funderingsbalken aanvullende balken 600x800 ten behoeve van opname horizontale belasting uit de bovenbouw, zie figuur 5- en figuur 5-.

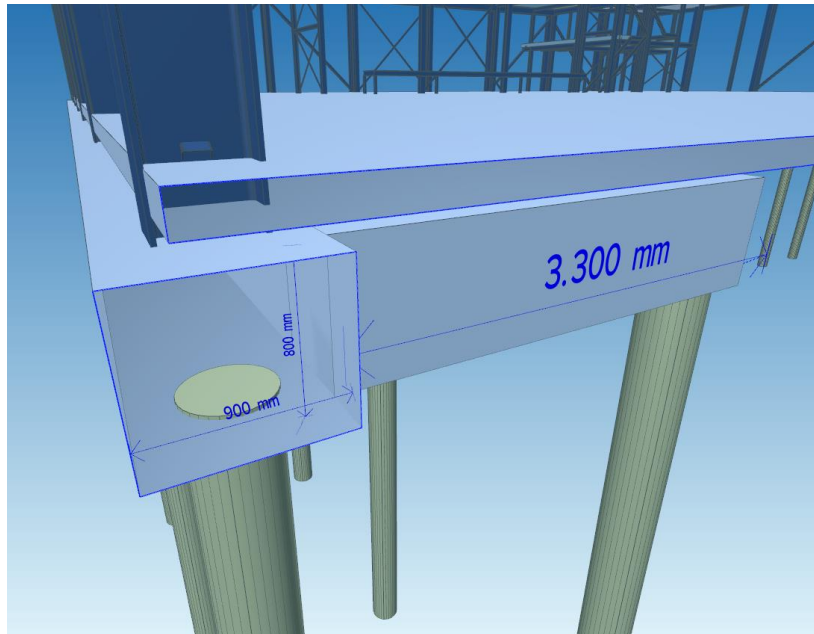

figuur 5-10

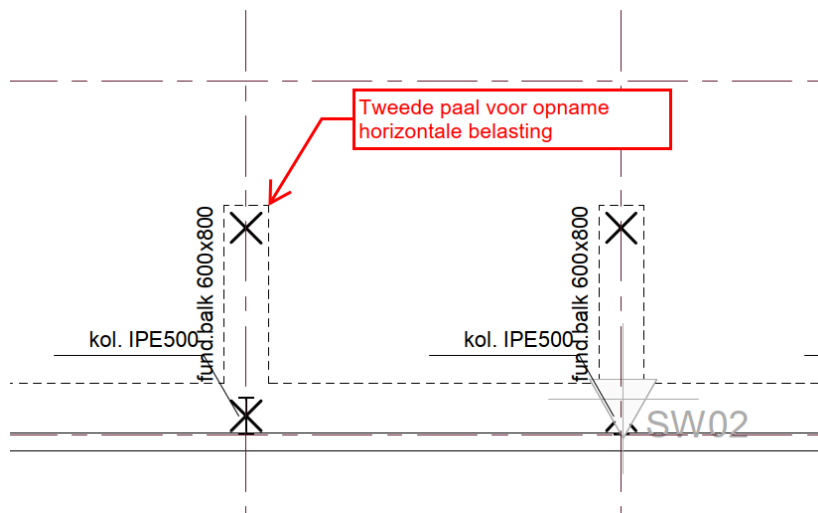

figuur 5-11

5.7 Staalberekening

Voor de staalberekening zie bijlage B.

Bijlage A

Berekening staalconstructie

A - 1 Dak berekening

Technosoft Raamwerken release 6.79a

17 jan 2024

Project.....: MM20152
 Dimensies....: kN;m;rad (tenzij anders aangegeven)
 Bestand.....: K:\Projecten\MM20152\10 Constructeur\03 DO - Definitief
 Ontwerp\reacties\dak.rww

Belastingbreedte.: 5.000
 Rekenmodel.....: 1e-orde-elastisch.
 Theorie voor de bepaling van de krachtsverdeling:
 Geometrisch lineair.
 Fysisch lineair.

Gunstige werking van de permanente belasting wordt automatisch verwerkt.

Toegepaste normen volgens Eurocode met Nederlandse NB

Belastingen	NEN-EN 1990:2002	C2:2010,A1:2019	NB:2019(nl)
	NEN-EN 1991-1-1:2002	C1/C11:2019	NB:2019(nl)
	NEN-EN 1991-1-4:2005	C2:2011	NB:2011(nl)
Staal	NEN-EN 1993-1-1:2006	C2:2011,A1:2016	NB:2016(nl)

GOMETRIE

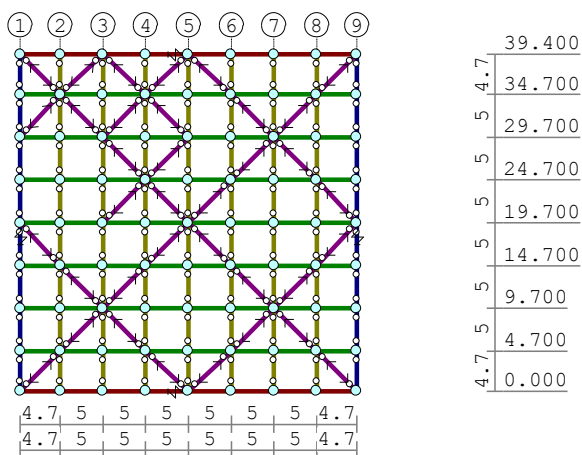

STRAMIENLIJNEN

Nr.	Naam	X	Z-min	Z-max
1	2	4.700	0.000	39.400
2	3	9.700	0.000	39.400
3	4	14.700	0.000	39.400
4	5	19.700	0.000	39.400
5	6	24.700	0.000	39.400
6	7	29.700	0.000	39.400
7	8	34.700	0.000	39.400
8	9	39.400	0.000	39.400
9	1	0.000	0.000	39.400

NIVEAUS

Nr.	Z	X-min	X-max
1	0.000	0.000	39.400
2	4.700	0.000	39.400
3	9.700	0.000	39.400
4	14.700	0.000	39.400
5	19.700	0.000	39.400
6	24.700	0.000	39.400
7	29.700	0.000	39.400
8	34.700	0.000	39.400
9	39.400	0.000	39.400

Onderdeel.....:

MATERIALEN

Mt	Kwaliteit	E-modulus[N/mm2]	S.G.	Pois.	Uitz. coëff
1	S235	210000	78.5	0.30	1.2000e-05

PROFIELEN [mm]

Prof.	Omschrijving	Materiaal	Oppervlak	Traagheid	Vormf.
1	HEA160	1:S235	3.8800e+03	1.6730e+07	0.00
2	IPE500	1:S235	1.1550e+04	4.8200e+08	0.00

3	K100/100/4HF	1:S235	1.5188e+03	2.3181e+06	0.00
4	K160/160/5CF	1:S235	3.0356e+03	1.2024e+07	0.00
5	H120/120/12	1:S235	2.7540e+03	3.6800e+06	0.00
6	IPE300	1:S235	5.3800e+03	8.3560e+07	0.00
7	IPE600	1:S235	1.5600e+04	9.2080e+08	0.00

PROFIELEN vervolg [mm]

Prof.	Staaftype	Breedte	Hoogte	e	Type	b1	h1	b2	h2
1	0:Normaal	160	152	76.0					
2	0:Normaal	200	500	250.0					
3	0:Normaal	100	100	50.0					
4	0:Normaal	160	160	80.0					
5	1:Trek	120	120	34.0					
6	0:Normaal	150	300	150.0					
7	0:Normaal	220	600	300.0					

PROFIELVORMEN [mm]

1 HEA160



2 IPE500



3 K100/100/4HF



4 K160/160/5CF



5 H120/120/12



6 IPE300



7 IPE600



KNOPEN

Knoop	X	Z	Knoop	X	Z
1	0.000	0.000	6	29.700	0.000
2	4.700	0.000	7	34.700	0.000
3	9.700	0.000	8	39.400	0.000
4	14.700	0.000	9	0.000	4.700
5	24.700	0.000	10	4.700	4.700
11	9.700	4.700	16	24.700	4.700

Onderdeel.....:

KNOPEN

Knoop	X	Z	Knoop	X	Z
12	29.700	4.700	17	19.700	4.700
13	34.700	4.700	18	19.700	0.000
14	39.400	4.700	19	-0.000	9.700
15	14.700	4.700	20	39.400	9.700
21	0.000	14.700	26	39.400	24.700
22	39.400	14.700	27	0.000	29.700
23	0.000	19.700	28	39.400	29.700
24	39.400	19.700	29	0.000	34.700
25	0.000	24.700	30	39.400	34.700
31	0.000	39.400	36	4.700	24.700
32	39.400	39.400	37	4.700	29.700
33	4.700	9.700	38	4.700	34.700
34	4.700	14.700	39	4.700	39.400
35	4.700	19.700	40	9.700	9.700
41	14.700	9.700	46	9.700	14.700
42	19.700	9.700	47	9.700	19.700
43	24.700	9.700	48	9.700	24.700
44	29.700	9.700	49	9.700	29.700
45	34.700	9.700	50	9.700	34.700

51	14.700	14.700	56	19.700	14.700
52	14.700	19.700	57	19.700	19.700
53	14.700	24.700	58	19.700	24.700
54	14.700	29.700	59	19.700	29.700
55	14.700	34.700	60	19.700	34.700
61	24.700	14.700	66	29.700	14.700
62	24.700	19.700	67	29.700	19.700
63	24.700	24.700	68	29.700	24.700
64	24.700	29.700	69	29.700	29.700
65	24.700	34.700	70	29.700	34.700
71	34.700	14.700	76	9.700	39.400
72	34.700	19.700	77	14.700	39.400
73	34.700	24.700	78	19.700	39.400
74	34.700	29.700	79	24.700	39.400
75	34.700	34.700	80	29.700	39.400
81	34.700	39.400			

STAVEN

St.	ki	kj	Profiel	Aansl.i	Aansl.j	Lengte	Opm.
1	9	10	2:IPE500	NDM	NDM	4.700	
2	10	11	2:IPE500	NDM	NDM	5.000	
3	11	15	2:IPE500	NDM	NDM	5.000	
4	12	13	2:IPE500	NDM	NDM	5.000	
5	13	14	2:IPE500	NDM	NDM	4.700	
6	15	17	2:IPE500	NDM	NDM	5.000	
7	16	12	2:IPE500	NDM	NDM	5.000	
8	17	16	2:IPE500	NDM	NDM	5.000	
9	19	33	2:IPE500	NDM	NDM	4.700	
10	21	34	2:IPE500	NDM	NDM	4.700	
11	23	35	2:IPE500	NDM	NDM	4.700	
12	25	36	2:IPE500	NDM	NDM	4.700	
13	27	37	2:IPE500	NDM	NDM	4.700	
14	29	38	2:IPE500	NDM	NDM	4.700	
15	1	9	4:K160/160/5CF	ND-	ND-	4.700	
16	9	19	4:K160/160/5CF	ND-	ND-	5.000	
17	19	21	4:K160/160/5CF	ND-	ND-	5.000	
18	21	23	4:K160/160/5CF	ND-	ND-	5.000	

Onderdeel.....:

STAVEN

St.	ki	kj	Profiel	Aansl.i	Aansl.j	Lengte	Opm.
19	23	25	4:K160/160/5CF	ND-	ND-	5.000	
20	25	27	4:K160/160/5CF	ND-	ND-	5.000	
21	27	29	4:K160/160/5CF	ND-	ND-	5.000	
22	29	31	4:K160/160/5CF	ND-	ND-	4.700	
23	14	20	4:K160/160/5CF	ND-	ND-	5.000	
24	20	22	4:K160/160/5CF	ND-	ND-	5.000	
25	22	24	4:K160/160/5CF	ND-	ND-	5.000	
26	24	26	4:K160/160/5CF	ND-	ND-	5.000	
27	26	28	4:K160/160/5CF	ND-	ND-	5.000	
28	28	30	4:K160/160/5CF	ND-	ND-	5.000	
29	30	32	4:K160/160/5CF	ND-	ND-	4.700	
30	31	39	1:HEA160	NDM	NDM	4.700	
31	2	10	3:K100/100/4HF	ND-	ND-	4.700	
32	10	33	3:K100/100/4HF	ND-	ND-	5.000	
33	33	40	2:IPE500	NDM	NDM	5.000	
34	33	34	3:K100/100/4HF	ND-	ND-	5.000	
35	34	46	2:IPE500	NDM	NDM	5.000	
36	34	35	3:K100/100/4HF	ND-	ND-	5.000	
37	35	47	2:IPE500	NDM	NDM	5.000	
38	35	36	3:K100/100/4HF	ND-	ND-	5.000	
39	36	48	2:IPE500	NDM	NDM	5.000	
40	36	37	3:K100/100/4HF	ND-	ND-	5.000	
41	37	49	2:IPE500	NDM	NDM	5.000	
42	37	38	3:K100/100/4HF	ND-	ND-	5.000	
43	38	50	2:IPE500	NDM	NDM	5.000	
44	38	39	3:K100/100/4HF	ND-	ND-	4.700	
45	39	76	1:HEA160	NDM	NDM	5.000	
46	40	41	2:IPE500	NDM	NDM	5.000	
47	41	42	2:IPE500	NDM	NDM	5.000	
48	42	43	2:IPE500	NDM	NDM	5.000	
49	43	44	2:IPE500	NDM	NDM	5.000	
50	45	20	2:IPE500	NDM	NDM	4.700	
51	3	11	3:K100/100/4HF	ND-	ND-	4.700	
52	11	40	3:K100/100/4HF	ND-	ND-	5.000	

53	40	46	3:K100/100/4HF	ND-	ND-	5.000
54	46	51	2:IPE500	NDM	NDM	5.000
55	46	47	3:K100/100/4HF	ND-	ND-	5.000
56	47	52	2:IPE500	NDM	NDM	5.000
57	41	15	3:K100/100/4HF	ND-	ND-	5.000
58	15	4	3:K100/100/4HF	ND-	ND-	4.700
59	42	17	3:K100/100/4HF	ND-	ND-	5.000
60	17	18	3:K100/100/4HF	ND-	ND-	4.700
61	43	16	3:K100/100/4HF	ND-	ND-	5.000
62	16	5	3:K100/100/4HF	ND-	ND-	4.700
63	12	6	3:K100/100/4HF	ND-	ND-	4.700
64	13	7	3:K100/100/4HF	ND-	ND-	4.700
65	45	13	3:K100/100/4HF	ND-	ND-	5.000
66	44	12	3:K100/100/4HF	ND-	ND-	5.000
67	8	14	4:K160/160/5CF	NDM	ND-	4.700
68	48	53	2:IPE500	NDM	NDM	5.000
69	49	54	2:IPE500	NDM	NDM	5.000
70	50	55	2:IPE500	NDM	NDM	5.000
71	51	56	2:IPE500	NDM	NDM	5.000
72	52	57	2:IPE500	NDM	NDM	5.000
73	53	58	2:IPE500	NDM	NDM	5.000

Onderdeel.....:

STAVEN

St.	ki	kj	Profiel	Aansl.i	Aansl.j	Lengte	Opm.
74	54	59	2:IPE500	NDM	NDM	5.000	
75	55	60	2:IPE500	NDM	NDM	5.000	
76	56	61	2:IPE500	NDM	NDM	5.000	
77	57	62	2:IPE500	NDM	NDM	5.000	
78	58	63	2:IPE500	NDM	NDM	5.000	
79	59	64	2:IPE500	NDM	NDM	5.000	
80	60	65	2:IPE500	NDM	NDM	5.000	
81	61	66	2:IPE500	NDM	NDM	5.000	
82	62	67	2:IPE500	NDM	NDM	5.000	
83	63	68	2:IPE500	NDM	NDM	5.000	
84	64	69	2:IPE500	NDM	NDM	5.000	
85	65	70	2:IPE500	NDM	NDM	5.000	
86	66	71	2:IPE500	NDM	NDM	5.000	
87	67	72	2:IPE500	NDM	NDM	5.000	
88	68	73	2:IPE500	NDM	NDM	5.000	
89	69	74	2:IPE500	NDM	NDM	5.000	
90	70	75	2:IPE500	NDM	NDM	5.000	
91	71	22	2:IPE500	NDM	NDM	4.700	
92	72	24	2:IPE500	NDM	NDM	4.700	
93	73	26	2:IPE500	NDM	NDM	4.700	
94	74	28	2:IPE500	NDM	NDM	4.700	
95	75	30	2:IPE500	NDM	NDM	4.700	
96	47	48	3:K100/100/4HF	ND-	ND-	5.000	
97	48	49	3:K100/100/4HF	ND-	ND-	5.000	
98	49	50	3:K100/100/4HF	ND-	ND-	5.000	
99	51	41	3:K100/100/4HF	ND-	ND-	5.000	
100	52	51	3:K100/100/4HF	ND-	ND-	5.000	
101	53	52	3:K100/100/4HF	ND-	ND-	5.000	
102	54	53	3:K100/100/4HF	ND-	ND-	5.000	
103	55	54	3:K100/100/4HF	ND-	ND-	5.000	
104	56	42	3:K100/100/4HF	ND-	ND-	5.000	
105	57	56	3:K100/100/4HF	ND-	ND-	5.000	
106	58	57	3:K100/100/4HF	ND-	ND-	5.000	
107	59	58	3:K100/100/4HF	ND-	ND-	5.000	
108	60	59	3:K100/100/4HF	ND-	ND-	5.000	
109	61	43	3:K100/100/4HF	ND-	ND-	5.000	
110	62	61	3:K100/100/4HF	ND-	ND-	5.000	
111	63	62	3:K100/100/4HF	ND-	ND-	5.000	
112	64	63	3:K100/100/4HF	ND-	ND-	5.000	
113	65	64	3:K100/100/4HF	ND-	ND-	5.000	
114	66	44	3:K100/100/4HF	ND-	ND-	5.000	
115	67	66	3:K100/100/4HF	ND-	ND-	5.000	
116	68	67	3:K100/100/4HF	ND-	ND-	5.000	
117	69	68	3:K100/100/4HF	ND-	ND-	5.000	
118	70	69	3:K100/100/4HF	ND-	ND-	5.000	
119	71	45	3:K100/100/4HF	ND-	ND-	5.000	
120	72	71	3:K100/100/4HF	ND-	ND-	5.000	
121	73	72	3:K100/100/4HF	ND-	ND-	5.000	
122	74	73	3:K100/100/4HF	ND-	ND-	5.000	
123	75	74	3:K100/100/4HF	ND-	ND-	5.000	

124	50	76	3:K100/100/4HF	ND-	ND-	4.700
125	76	77	1:HEA160	NDM	NDM	5.000
126	77	55	3:K100/100/4HF	ND-	ND-	4.700
127	77	78	1:HEA160	NDM	NDM	5.000
128	78	60	3:K100/100/4HF	ND-	ND-	4.700

Onderdeel.....:

STAVEN

St.	ki	kj	Profiel	Aansl.i	Aansl.j	Lengte	Opm.
129	78	79	1:HEA160	NDM	NDM	5.000	
130	79	65	3:K100/100/4HF	ND-	ND-	4.700	
131	79	80	1:HEA160	NDM	NDM	5.000	
132	80	70	3:K100/100/4HF	ND-	ND-	4.700	
133	80	81	1:HEA160	NDM	NDM	5.000	
134	81	75	3:K100/100/4HF	ND-	ND-	4.700	
135	81	32	1:HEA160	NDM	NDM	4.700	
136	1	10	5:H120/120/12	ND-	ND-	6.647	
137	10	40	5:H120/120/12	ND-	ND-	7.071	
138	40	51	5:H120/120/12	ND-	ND-	7.071	
139	51	57	5:H120/120/12	ND-	ND-	7.071	
140	57	63	5:H120/120/12	ND-	ND-	7.071	
141	63	69	5:H120/120/12	ND-	ND-	7.071	
142	69	75	5:H120/120/12	ND-	ND-	7.071	
143	75	32	5:H120/120/12	ND-	ND-	6.647	
144	57	61	5:H120/120/12	ND-	ND-	7.071	
145	61	44	5:H120/120/12	ND-	ND-	7.071	
146	53	57	5:H120/120/12	ND-	ND-	7.071	
147	44	45	2:IPE500	NDM	NDM	5.000	
148	44	13	5:H120/120/12	ND-	ND-	7.071	
149	13	8	5:H120/120/12	ND-	ND-	6.647	
150	49	53	5:H120/120/12	ND-	ND-	7.071	
151	38	49	5:H120/120/12	ND-	ND-	7.071	
152	31	38	5:H120/120/12	ND-	ND-	6.647	
153	18	16	5:H120/120/12	ND-	ND-	6.862	
154	16	44	5:H120/120/12	ND-	ND-	7.071	
155	44	71	5:H120/120/12	ND-	ND-	7.071	
156	71	24	5:H120/120/12	ND-	ND-	6.862	
157	18	15	5:H120/120/12	ND-	ND-	6.862	
158	15	40	5:H120/120/12	ND-	ND-	7.071	
159	40	34	5:H120/120/12	ND-	ND-	7.071	
160	34	23	5:H120/120/12	ND-	ND-	6.862	
161	49	55	5:H120/120/12	ND-	ND-	7.071	
162	55	78	5:H120/120/12	ND-	ND-	6.862	
163	78	65	5:H120/120/12	ND-	ND-	6.862	
164	65	69	5:H120/120/12	ND-	ND-	7.071	
165	69	73	5:H120/120/12	ND-	ND-	7.071	
166	73	24	5:H120/120/12	ND-	ND-	6.862	
167	1	2	1:HEA160	NDM	NDM	4.700	
168	2	3	1:HEA160	NDM	NDM	5.000	
169	3	4	1:HEA160	NDM	NDM	5.000	
170	4	18	1:HEA160	NDM	NDM	5.000	
171	18	5	1:HEA160	NDM	NDM	5.000	
172	5	6	1:HEA160	NDM	NDM	5.000	
173	6	7	1:HEA160	NDM	NDM	5.000	
174	7	8	1:HEA160	NDM	NDM	4.700	
175	76	55	5:H120/120/12	ND-	ND-	6.862	
176	55	59	5:H120/120/12	ND-	ND-	7.071	
177	59	53	5:H120/120/12	ND-	ND-	7.071	
178	53	47	5:H120/120/12	ND-	ND-	7.071	
179	27	38	5:H120/120/12	ND-	ND-	6.862	
180	38	76	5:H120/120/12	ND-	ND-	6.862	

VEREN

Veer	Knoop	Richting	Hoek	Veerwaarde	Type	Ondergrens	Bovengrens
1	18	1:X-transl.	0.00	1.530e+04	Normaal	-1.000e+10	1.000e+10

Onderdeel.....:

VEREN

Veer	Knoop	Richting	Hoek	Veerwaarde	Type	Ondergrens	Bovengrens
2	23	2:Z-transl.	0.00	2.100e+04	Normaal	-1.000e+10	1.000e+10
3	24	2:Z-transl.	0.00	2.100e+04	Normaal	-1.000e+10	1.000e+10
4	78	1:X-transl.	0.00	1.530e+04	Normaal	-1.000e+10	1.000e+10

BELASTINGGEVALLEN

B.G.	Omschrijving	Type
------	--------------	------

- 1 x+
- 2 y+
- 3 Knik
- 4 y-

- 7 Wind van links onderdruk A
- 14 Wind van rechts overdruk B
- 0 Onbekend
- 14 Wind van rechts overdruk B

BELASTINGEN

B.G:1 x+

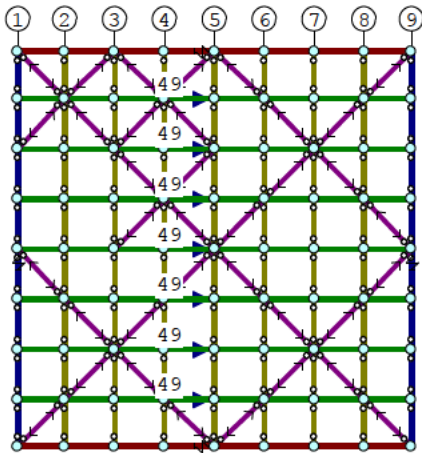

KNOOPBELASTINGEN

B.G:1 x+

Last	Knoop	Richting	waarde	ψ_0	ψ_1	ψ_2
1	60	X	49.000	0.00	0.20	0.00
2	59	X	49.000	0.00	0.20	0.00
3	58	X	49.000	0.00	0.20	0.00
4	57	X	49.000	0.00	0.20	0.00
5	56	X	49.000	0.00	0.20	0.00
6	42	X	49.000	0.00	0.20	0.00
7	17	X	49.000	0.00	0.20	0.00

REACTIES

B.G:1 x+

Kn.	X	Z	M
18	-165.00		
23		6.50	
24		-6.50	
78	-178.00		
-343.00 0.00 : Som van de reacties			
343.00 0.00 : Som van de belastingen			

Onderdeel.....:

BELASTINGEN

B.G:2 y+

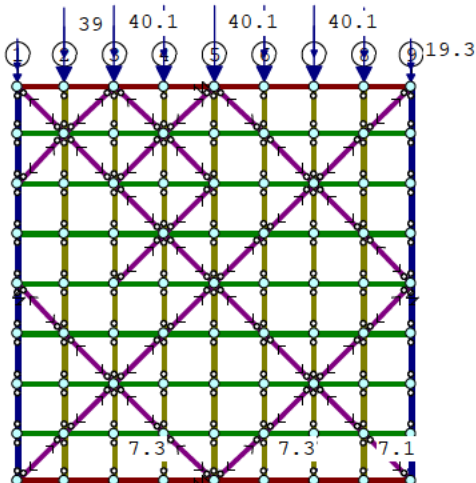

KNOOPBELASTINGEN

B.G:2 y+

Last	Knoop	Richting	waarde	ψ_0	ψ_1	ψ_2
1	39	Z	-39.000	0.00	0.20	0.00
2	76	Z	-40.100	0.00	0.20	0.00
3	77	Z	-40.100	0.00	0.20	0.00
4	78	Z	-40.100	0.00	0.20	0.00
5	79	Z	-40.100	0.00	0.20	0.00
6	80	Z	-40.100	0.00	0.20	0.00
7	81	Z	-39.000	0.00	0.20	0.00
8	32	Z	-19.300	0.00	0.20	0.00

9	31 Z	-19.300	0.00	0.20	0.00
10	1 Z	-3.500	0.00	0.20	0.00
11	8 Z	-3.500	0.00	0.20	0.00
12	2 Z	-7.100	0.00	0.20	0.00
13	7 Z	-7.100	0.00	0.20	0.00
14	3 Z	-7.300	0.00	0.20	0.00
15	4 Z	-7.300	0.00	0.20	0.00
16	18 Z	-7.300	0.00	0.20	0.00
17	5 Z	-7.300	0.00	0.20	0.00
18	6 Z	-7.300	0.00	0.20	0.00
19	31 Z	-1.510	0.00	0.20	0.00
20	39 Z	-1.510	0.00	0.20	0.00
21	76 Z	-1.510	0.00	0.20	0.00
22	77 Z	-1.510	0.00	0.20	0.00
23	79 Z	-1.510	0.00	0.20	0.00
24	80 Z	-1.510	0.00	0.20	0.00
25	81 Z	-1.510	0.00	0.20	0.00
26	32 Z	-1.510	0.00	0.20	0.00

REACTIES

B.G:2 y+

Kn.	X	Z	M
18	0.00		
23		193.44	
24		193.44	
78	-0.00		

0.00 386.88 : Som van de reacties

0.00 -386.88 : Som van de belastingen

Onderdeel....:

BELASTINGEN

B.G:3 Knik

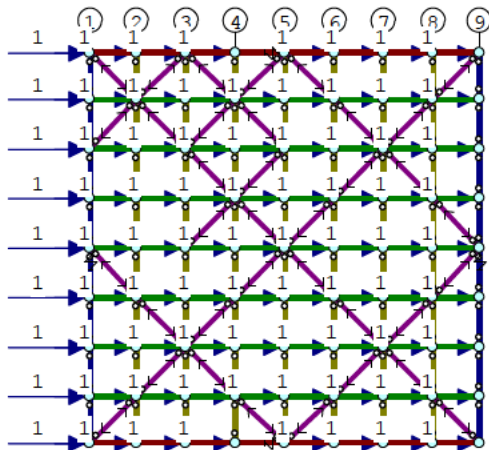

KNOOPBELASTINGEN

B.G:3 Knik

Last	Knoop	Richting	waarde	ψ_0	ψ_1	ψ_2
1	1	X	1.000			
2	2	X	1.000			
3	3	X	1.000			
4	4	X	1.000			
5	5	X	1.000			
6	6	X	1.000			
7	7	X	1.000			
8	8	X	1.000			
9	9	X	1.000			
10	10	X	1.000			
11	11	X	1.000			
12	12	X	1.000			
13	13	X	1.000			
14	14	X	1.000			
15	15	X	1.000			
16	16	X	1.000			
17	17	X	1.000			
18	18	X	1.000			
19	20	X	1.000			
20	21	X	1.000			
21	22	X	1.000			
22	23	X	1.000			
23	24	X	1.000			
24	25	X	1.000			
25	26	X	1.000			
26	27	X	1.000			
27	28	X	1.000			
28	29	X	1.000			
29	30	X	1.000			
30	31	X	1.000			
31	32	X	1.000			

32	33 X	1.000
33	34 X	1.000
34	35 X	1.000
35	36 X	1.000
36	37 X	1.000
37	38 X	1.000
38	39 X	1.000
39	40 X	1.000
40	41 X	1.000
41	42 X	1.000
42	43 X	1.000
43	44 X	1.000
44	45 X	1.000

Onderdeel....:

KNOOPBELASTINGEN

B.G:3 Knik

Last	Knoop	Richting	waarde	Ψ_0	Ψ_1	Ψ_2
45	46 X		1.000			
46	47 X		1.000			
47	48 X		1.000			
48	49 X		1.000			
49	50 X		1.000			
50	51 X		1.000			
51	52 X		1.000			
52	53 X		1.000			
53	54 X		1.000			
54	55 X		1.000			
55	56 X		1.000			
56	57 X		1.000			
57	58 X		1.000			
58	59 X		1.000			
59	60 X		1.000			
60	61 X		1.000			
61	62 X		1.000			
62	63 X		1.000			
63	64 X		1.000			
64	65 X		1.000			
65	66 X		1.000			
66	67 X		1.000			
67	68 X		1.000			
68	69 X		1.000			
69	70 X		1.000			
70	71 X		1.000			
71	72 X		1.000			
72	73 X		1.000			
73	74 X		1.000			
74	75 X		1.000			
75	76 X		1.000			
76	77 X		1.000			
77	79 X		1.000			
78	80 X		1.000			
79	81 X		1.000			

REACTIES

B.G:3 Knik

Kn.	X	Z	M
18	-38.32		
23		1.18	
24		-1.18	
78	-40.68		
<hr/>			
	-79.00	0.00	: Som van de reacties

Onderdeel....: 79.00 0.00 : Som van de belastingen

BELASTINGEN

B.G:4 y-

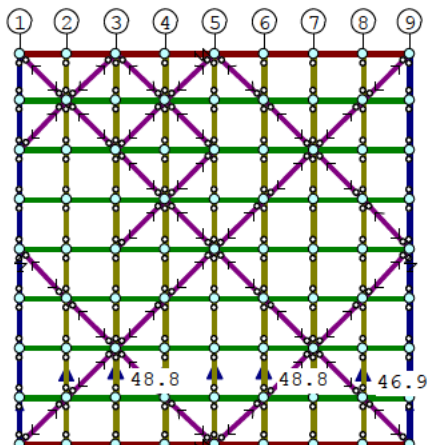

KNOOPBELASTINGEN

B.G:4 y-

Last	Knoop	Richting	waarde	Ψ_0	Ψ_1	Ψ_2
1	7	Z	46.900	0.00	0.20	0.00
2	18	Z	48.800	0.00	0.20	0.00
3	6	Z	48.800	0.00	0.20	0.00
4	5	Z	48.800	0.00	0.20	0.00
5	4	Z	48.800	0.00	0.20	0.00
6	3	Z	48.800	0.00	0.20	0.00
7	2	Z	46.900	0.00	0.20	0.00
8	8	Z	23.200	0.00	0.20	0.00
9	1	Z	23.200	0.00	0.20	0.00

REACTIES

B.G:4 y-

Kn.	X	Z	M
18	5.54		
23		-186.56	
24		-197.64	
78	-5.54		
0.00 -384.20 : Som van de reacties			
0.00 384.20 : Som van de belastingen			

IMPERFECTIES

Scheefstand : 0.00500 * Hoogte
 Deze imperfecties worden conform de opgegeven imperfectie situatie aangebracht.
 Lokale staaf imperfecties worden niet meegenomen.

IMPERFECTIE SITUATIES

Nr.	Omschrijving	Scheefstand	Geldt voor belastingcombinaties
1	Geen imperfecties	0:geen	Alle fundamentele combinaties.
2	imperfecties naar rechts	1:Naar links	Alle fundamentele combinaties.
3	imperfecties naar links	2:Naar Rechts	Alle fundamentele combinaties.

Onderdeel....:

IMPERFECTIEGEGEVENS [mm]

Situatie:1:Geen imperfecties

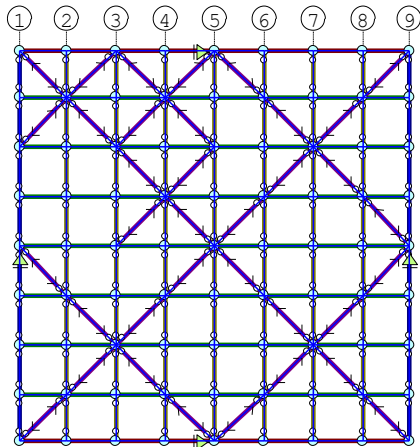

IMPERFECTIEGEGEVENS [mm]

Situatie:1:Geen imperfecties

Nr.	Knoop	Type	Verplaatsing
1	18	1:Vast in X	
2	23	2:Vast in Z	
3	24	2:Vast in Z	
4	78	1:Vast in X	

IMPERFECTIEGEGEVENS [mm]

Situatie:2:imperfecties naar rechts

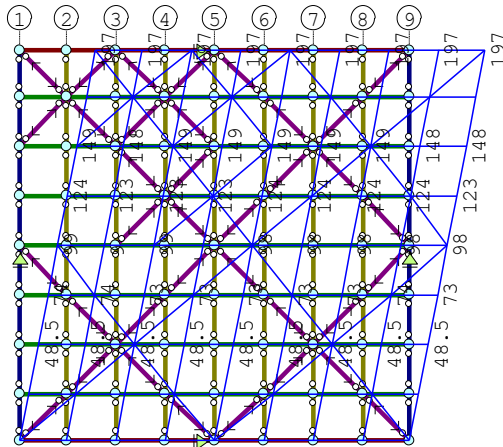

IMPERFECTIEGEGEVENS [mm]

Situatie:2:imperfecties naar rechts

Nr.	Knoop	Type	Verplaatsing
1	18	1:Vast in X	
2	23	2:Vast in Z	
3	24	2:Vast in Z	
4	78	1:Vast in X	

Onderdeel.....:

IMPERFECTIEGEGEVENS [mm]

Situatie:3:imperfecties naar links

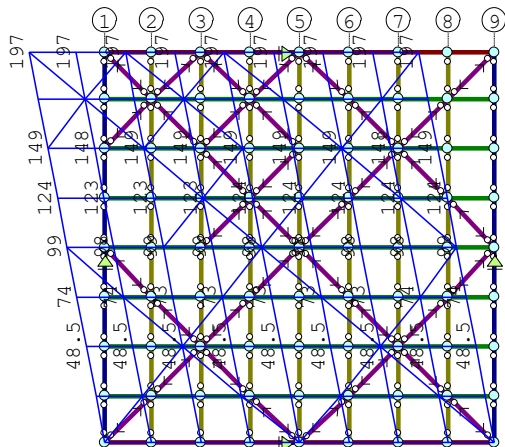

IMPERFECTIEGEGEVENS [mm]

Situatie:3:imperfecties naar links

Nr.	Knoop	Type	Verplaatsing
1	18	1:Vast in X	
2	23	2:Vast in Z	
3	24	2:Vast in Z	
4	78	1:Vast in X	

BELASTINGCOMBINATIES

BC	Type	
1	Fund.	1.50 $Q_{k,1}$
2	Fund.	1.50 $Q_{k,2}$
3	Kar.	1.00 $Q_{k,1}$
4	Kar.	1.00 $Q_{k,2}$

OMHULLENDE VAN DE FUNDAMENTELE COMBINATIES

MOMENTEN

Fundamentele combinatie

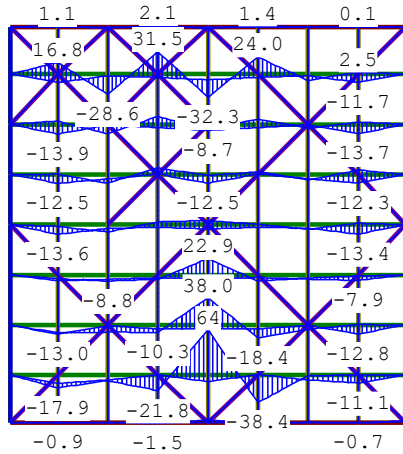

Onderdeel.....:

DWARSKRACHTEN

Fundamentele combinatie

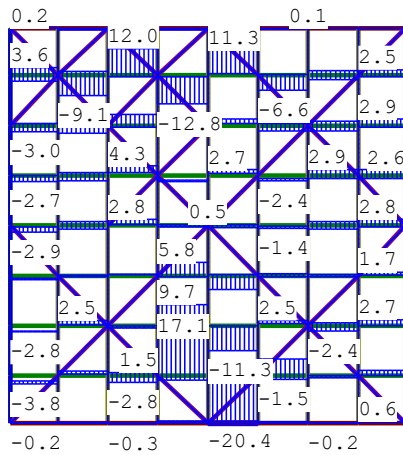

NORMAALKRACHTEN

Fundamentele combinatie

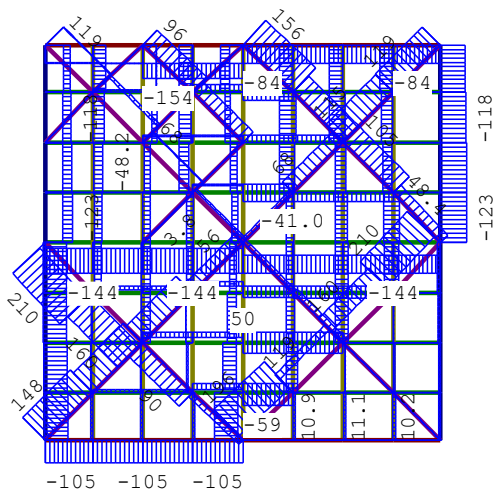

REACTIES

Fundamentele combinatie

Kn.	X-min	X-max	Z-min	Z-max	M-min	M-max
18	-247.70	0.95				
23			9.55	290.24		
24			-9.94	290.23		
78	-267.19	0.93				

Onderdeel.....:

OMHULLENDE VAN DE KARAKTERISTIEKE COMBINATIES

VERPLAATSINGEN [mm]

Karakteristieke combinatie

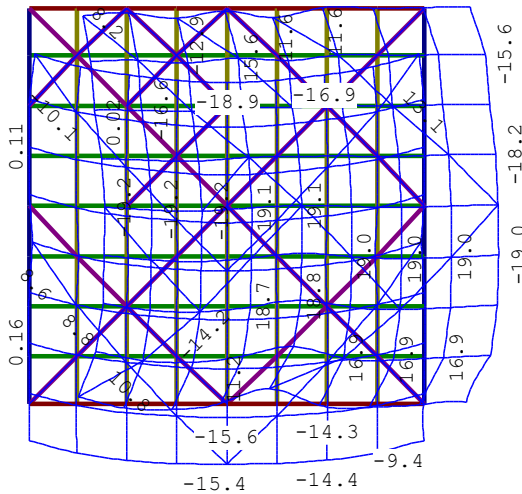

STAALPROFIELEN - ALGEMENE GEGEVENS

Stabiliteit: Classificatie gehele constructie: Ongeschoord
 Belastinggeval m.b.t. bepaling kniklengte: 3=Knik
 Aanpassing inkl. parameter C : Steunpunten
 Tweede-orde-effect:
 Aan te houden verhouding n/(n-1) voor steunmomenten en verplaatsingen: 1.10
 Doorbuiging en verplaatsing:
 Aantal bouwlagen: 1
 Gebouwtype: Overig
 Toel. horiz. verplaatsing gehele gebouw: h/300
 Kleinste gevelhoogte [m]: 0.0

PROFIEL/MATERIAAL

P/M nr.	Profielnaam	Vloeisp. [N/mm ²]	Productie methode	Min. drsn. klasse
1	HEA160	235	Gewalst	1
2	IPE500	235	Gewalst	1
3	K100/100/4HF	235	Warmgewalst	1
4	K160/160/5CF	235	Koudgevormd	1
5	HI20/120/12	235	Gewalst	1
6	IPE300	235	Gewalst	1
7	IPE600	235	Gewalst	1

Partiële veiligheidsfactoren:

Gamma M;0 : 1.00 Gamma M;1 : 1.00

KNIKSTABILITEIT

Staafl	l _{sys} [m]	Classif. y sterke as	l _{knik;y} [m]	Extra aanp. y [kN]	Classif. z zwakke as	l _{knik;z} [m]	Extra aanp. z [kN]
1	4.700	Ongeschoord	4.700*	0.0	Geschoord	4.700	0.0
2	5.000	Ongeschoord	5.000*	0.0	Geschoord	5.000	0.0
3	5.000	Ongeschoord	5.000*	0.0	Geschoord	5.000	0.0
4	5.000	Ongeschoord	5.000*	0.0	Geschoord	5.000	0.0
5	4.700	Ongeschoord	4.700*	0.0	Geschoord	4.700	0.0
6	5.000	Ongeschoord	5.000*	0.0	Geschoord	5.000	0.0
7	5.000	Ongeschoord	5.000*	0.0	Geschoord	5.000	0.0
8	5.000	Ongeschoord	5.000*	0.0	Geschoord	5.000	0.0
9	4.700	Ongeschoord	4.700*	0.0	Geschoord	4.700	0.0
10	4.700	Ongeschoord	4.700*	0.0	Geschoord	4.700	0.0

Onderdeel....:

KNIKSTABILITEIT

Staafl	l _{sys} [m]	Classif. y sterke as	l _{knik;y} [m]	Extra aanp. y [kN]	Classif. z zwakke as	l _{knik;z} [m]	Extra aanp. z [kN]
11	4.700	Ongeschoord	4.700*	0.0	Geschoord	4.700	0.0
12	4.700	Ongeschoord	4.700*	0.0	Geschoord	4.700	0.0
13	4.700	Ongeschoord	4.700*	0.0	Geschoord	4.700	0.0
14	4.700	Ongeschoord	4.700*	0.0	Geschoord	4.700	0.0
15	4.700	Geschoord	4.700	4.7	Geschoord	4.700	0.0
16	5.000	Geschoord	5.000	0.0	Geschoord	5.000	0.0
17	5.000	Geschoord	5.000	0.0	Geschoord	5.000	0.0
18	5.000	Geschoord	5.000	0.0	Geschoord	5.000	0.0
19	5.000	Geschoord	5.000	0.0	Geschoord	5.000	0.0
20	5.000	Geschoord	5.000	0.0	Geschoord	5.000	0.0

21	5.000	Geschoord	5.000	0.0	Geschoord	5.000	0.0
22	4.700	Geschoord	4.700	0.0	Geschoord	4.700	0.0
23	5.000	Geschoord	5.000	0.0	Geschoord	5.000	0.0
24	5.000	Geschoord	5.000	0.0	Geschoord	5.000	0.0
25	5.000	Geschoord	5.000	0.0	Geschoord	5.000	0.0
26	5.000	Geschoord	5.000	0.0	Geschoord	5.000	0.0
27	5.000	Geschoord	5.000	0.0	Geschoord	5.000	0.0
28	5.000	Geschoord	5.000	0.0	Geschoord	5.000	0.0
29	4.700	Geschoord	4.700*	0.0	Geschoord	4.700	0.0
30	4.700	Ongeschoord	4.700*	0.0	Geschoord	4.700	0.0
31	4.700	Geschoord	4.700	0.0	Geschoord	4.700	0.0
32	5.000	Geschoord	5.000	0.0	Geschoord	5.000	0.0
33	5.000	Ongeschoord	5.000*	0.0	Geschoord	5.000	0.0
34	5.000	Geschoord	5.000	0.0	Geschoord	5.000	0.0
35	5.000	Ongeschoord	5.000*	0.0	Geschoord	5.000	0.0
36	5.000	Geschoord	5.000	0.0	Geschoord	5.000	0.0
37	5.000	Ongeschoord	5.000*	0.0	Geschoord	5.000	0.0
38	5.000	Geschoord	5.000	0.0	Geschoord	5.000	0.0
39	5.000	Ongeschoord	5.000*	0.0	Geschoord	5.000	0.0
40	5.000	Geschoord	5.000	0.0	Geschoord	5.000	0.0
41	5.000	Ongeschoord	5.000*	0.0	Geschoord	5.000	0.0
42	5.000	Geschoord	5.000	0.0	Geschoord	5.000	0.0
43	5.000	Ongeschoord	5.000*	0.0	Geschoord	5.000	0.0
44	4.700	Geschoord	4.700	0.0	Geschoord	4.700	0.0
45	5.000	Ongeschoord	5.000*	0.0	Geschoord	5.000	0.0
46	5.000	Ongeschoord	5.000*	0.0	Geschoord	5.000	0.0
47	5.000	Ongeschoord	5.000*	0.0	Geschoord	5.000	0.0
48	5.000	Ongeschoord	5.000*	0.0	Geschoord	5.000	0.0
49	5.000	Ongeschoord	5.000*	0.0	Geschoord	5.000	0.0
50	4.700	Ongeschoord	4.700*	0.0	Geschoord	4.700	0.0
51	4.700	Geschoord	4.700	0.0	Geschoord	4.700	0.0
52	5.000	Geschoord	5.000	0.0	Geschoord	5.000	0.0
53	5.000	Geschoord	5.000	0.0	Geschoord	5.000	0.0
54	5.000	Ongeschoord	5.000*	0.0	Geschoord	5.000	0.0
55	5.000	Geschoord	5.000	0.0	Geschoord	5.000	0.0
56	5.000	Ongeschoord	5.000*	0.0	Geschoord	5.000	0.0
57	5.000	Geschoord	5.000	0.0	Geschoord	5.000	0.0
58	4.700	Geschoord	4.700	0.0	Geschoord	4.700	0.0
59	5.000	Geschoord	5.000	0.0	Geschoord	5.000	0.0
60	4.700	Geschoord	4.700	0.0	Geschoord	4.700	0.0
61	5.000	Geschoord	5.000	0.0	Geschoord	5.000	0.0
62	4.700	Geschoord	4.700	0.0	Geschoord	4.700	0.0
63	4.700	Geschoord	4.700	0.0	Geschoord	4.700	0.0
64	4.700	Geschoord	4.700	0.0	Geschoord	4.700	0.0
65	5.000	Geschoord	5.000	0.0	Geschoord	5.000	0.0

Onderdeel.....:

KNIKSTABILITEIT

Staafl	l_{sys} [m]	Classif. y sterke as	$l_{knik,y}$ [m]	Extra aanp. y [kN]	Classif. z zwakke as	$l_{knik,z}$ [m]	Extra aanp. z [kN]
66	5.000	Geschoord	5.000	0.0	Geschoord	5.000	0.0
67	4.700	Ongeschoord	4.700*	0.0	Geschoord	4.700	0.0
68	5.000	Ongeschoord	5.000*	0.0	Geschoord	5.000	0.0
69	5.000	Ongeschoord	5.000*	0.0	Geschoord	5.000	0.0
70	5.000	Ongeschoord	5.000*	0.0	Geschoord	5.000	0.0
71	5.000	Ongeschoord	5.000*	0.0	Geschoord	5.000	0.0
72	5.000	Ongeschoord	5.000*	0.0	Geschoord	5.000	0.0
73	5.000	Ongeschoord	5.000*	0.0	Geschoord	5.000	0.0
74	5.000	Ongeschoord	5.000*	0.0	Geschoord	5.000	0.0
75	5.000	Ongeschoord	5.000*	0.0	Geschoord	5.000	0.0
76	5.000	Ongeschoord	5.000*	0.0	Geschoord	5.000	0.0
77	5.000	Ongeschoord	5.000*	0.0	Geschoord	5.000	0.0
78	5.000	Ongeschoord	5.000*	0.0	Geschoord	5.000	0.0
79	5.000	Ongeschoord	5.000*	0.0	Geschoord	5.000	0.0
80	5.000	Ongeschoord	5.000*	0.0	Geschoord	5.000	0.0
81	5.000	Ongeschoord	5.000*	0.0	Geschoord	5.000	0.0
82	5.000	Ongeschoord	5.000*	0.0	Geschoord	5.000	0.0
83	5.000	Ongeschoord	5.000*	0.0	Geschoord	5.000	0.0
84	5.000	Ongeschoord	5.000*	0.0	Geschoord	5.000	0.0
85	5.000	Ongeschoord	5.000*	0.0	Geschoord	5.000	0.0
86	5.000	Ongeschoord	5.000*	0.0	Geschoord	5.000	0.0
87	5.000	Ongeschoord	5.000*	0.0	Geschoord	5.000	0.0
88	5.000	Ongeschoord	5.000*	0.0	Geschoord	5.000	0.0
89	5.000	Ongeschoord	5.000*	0.0	Geschoord	5.000	0.0
90	5.000	Ongeschoord	5.000*	0.0	Geschoord	5.000	0.0

91	4.700	Ongeschoord	4.700*	0.0	Geschoord	4.700	0.0
92	4.700	Ongeschoord	4.700*	0.0	Geschoord	4.700	0.0
93	4.700	Ongeschoord	4.700*	0.0	Geschoord	4.700	0.0
94	4.700	Ongeschoord	4.700*	0.0	Geschoord	4.700	0.0
95	4.700	Ongeschoord	4.700*	0.0	Geschoord	4.700	0.0
96	5.000	Geschoord	5.000	0.0	Geschoord	5.000	0.0
97	5.000	Geschoord	5.000	0.0	Geschoord	5.000	0.0
98	5.000	Geschoord	5.000	0.0	Geschoord	5.000	0.0
99	5.000	Geschoord	5.000	0.0	Geschoord	5.000	0.0
100	5.000	Geschoord	5.000	0.0	Geschoord	5.000	0.0
101	5.000	Geschoord	5.000	0.0	Geschoord	5.000	0.0
102	5.000	Geschoord	5.000	0.0	Geschoord	5.000	0.0
103	5.000	Geschoord	5.000	0.0	Geschoord	5.000	0.0
104	5.000	Geschoord	5.000	0.0	Geschoord	5.000	0.0
105	5.000	Geschoord	5.000	0.0	Geschoord	5.000	0.0
106	5.000	Geschoord	5.000	0.0	Geschoord	5.000	0.0
107	5.000	Geschoord	5.000	0.0	Geschoord	5.000	0.0
108	5.000	Geschoord	5.000	0.0	Geschoord	5.000	0.0
109	5.000	Geschoord	5.000	0.0	Geschoord	5.000	0.0
110	5.000	Geschoord	5.000	0.0	Geschoord	5.000	0.0
111	5.000	Geschoord	5.000	0.0	Geschoord	5.000	0.0
112	5.000	Geschoord	5.000	0.0	Geschoord	5.000	0.0
113	5.000	Geschoord	5.000	0.0	Geschoord	5.000	0.0
114	5.000	Geschoord	5.000	0.0	Geschoord	5.000	0.0
115	5.000	Geschoord	5.000	0.0	Geschoord	5.000	0.0
116	5.000	Geschoord	5.000	0.0	Geschoord	5.000	0.0
117	5.000	Geschoord	5.000	0.0	Geschoord	5.000	0.0
118	5.000	Geschoord	5.000	0.0	Geschoord	5.000	0.0
119	5.000	Geschoord	5.000	0.0	Geschoord	5.000	0.0
120	5.000	Geschoord	5.000	0.0	Geschoord	5.000	0.0

Onderdeel....:

KNIKSTABILITEIT

Staaft	l _{sys} [m]	Classif. y sterke as	l _{knik,y} [m]	Extra		Extra	
				aanp. y [kN]	Classif. z zwakke as	l _{knik,z} [m]	aanp. z [kN]
121	5.000	Geschoord	5.000	0.0	Geschoord	5.000	0.0
122	5.000	Geschoord	5.000	0.0	Geschoord	5.000	0.0
123	5.000	Geschoord	5.000	0.0	Geschoord	5.000	0.0
124	4.700	Geschoord	4.700	0.0	Geschoord	4.700	0.0
125	5.000	Ongeschoord	5.000*	0.0	Geschoord	5.000	0.0
126	4.700	Geschoord	4.700	0.0	Geschoord	4.700	0.0
127	5.000	Ongeschoord	5.000*	0.0	Geschoord	5.000	0.0
128	4.700	Geschoord	4.700	0.0	Geschoord	4.700	0.0
129	5.000	Ongeschoord	5.000*	0.0	Geschoord	5.000	0.0
130	4.700	Geschoord	4.700	0.0	Geschoord	4.700	0.0
131	5.000	Ongeschoord	5.000*	0.0	Geschoord	5.000	0.0
132	4.700	Geschoord	4.700	0.0	Geschoord	4.700	0.0
133	5.000	Ongeschoord	5.000*	0.0	Geschoord	5.000	0.0
134	4.700	Geschoord	4.700	0.0	Geschoord	4.700	0.0
135	4.700	Ongeschoord	4.700*	0.0	Geschoord	4.700	0.0
136	6.647	Geschoord	6.647	0.0	Geschoord	6.647	0.0
137	7.071	Geschoord	7.071	0.0	Geschoord	7.071	0.0
138	7.071	Geschoord	7.071	0.0	Geschoord	7.071	0.0
139	7.071	Geschoord	7.071	0.0	Geschoord	7.071	0.0
140	7.071	Geschoord	7.071	0.0	Geschoord	7.071	0.0
141	7.071	Geschoord	7.071	0.0	Geschoord	7.071	0.0
142	7.071	Geschoord	7.071	0.0	Geschoord	7.071	0.0
143	6.647	Geschoord	6.647	0.0	Geschoord	6.647	0.0
144	7.071	Geschoord	7.071	0.0	Geschoord	7.071	0.0
145	7.071	Geschoord	7.071	0.0	Geschoord	7.071	0.0
146	7.071	Geschoord	7.071	0.0	Geschoord	7.071	0.0
147	5.000	Ongeschoord	5.000*	0.0	Geschoord	5.000	0.0
148	7.071	Geschoord	7.071*	0.0	Geschoord	7.071	0.0
149	6.647	Geschoord	6.647*	0.0	Geschoord	6.647	0.0
150	7.071	Geschoord	7.071	0.0	Geschoord	7.071	0.0
151	7.071	Geschoord	7.071	0.0	Geschoord	7.071	0.0
152	6.647	Geschoord	6.647	0.0	Geschoord	6.647	0.0
153	6.862	Geschoord	6.862*	0.0	Geschoord	6.862	0.0
154	7.071	Geschoord	7.071*	0.0	Geschoord	7.071	0.0
155	7.071	Geschoord	7.071*	0.0	Geschoord	7.071	0.0
156	6.862	Geschoord	6.862*	0.0	Geschoord	6.862	0.0
157	6.862	Geschoord	6.862*	0.0	Geschoord	6.862	0.0
158	7.071	Geschoord	7.071*	0.0	Geschoord	7.071	0.0
159	7.071	Geschoord	7.071*	0.0	Geschoord	7.071	0.0
160	6.862	Geschoord	6.862*	0.0	Geschoord	6.862	0.0

161	7.071	Geschoord	7.071*	0.0	Geschoord	7.071	0.0
162	6.862	Geschoord	6.862*	0.0	Geschoord	6.862	0.0
163	6.862	Geschoord	6.862*	0.0	Geschoord	6.862	0.0
164	7.071	Geschoord	7.071*	0.0	Geschoord	7.071	0.0
165	7.071	Geschoord	7.071*	0.0	Geschoord	7.071	0.0
166	6.862	Geschoord	6.862*	0.0	Geschoord	6.862	0.0
167	4.700	Ongeschoord	4.000*	0.0	Geschoord	4.700	0.0
168	5.000	Ongeschoord	5.000*	0.0	Geschoord	5.000	0.0
169	5.000	Ongeschoord	5.000*	0.0	Geschoord	5.000	0.0
170	5.000	Ongeschoord	5.000*	0.0	Geschoord	5.000	0.0
171	5.000	Ongeschoord	5.000*	0.0	Geschoord	5.000	0.0
172	5.000	Ongeschoord	5.000*	0.0	Geschoord	5.000	0.0
173	5.000	Ongeschoord	5.000*	0.0	Geschoord	5.000	0.0
174	4.700	Ongeschoord	4.700*	0.0	Geschoord	4.700	0.0
175	6.862	Geschoord	6.862	0.0	Geschoord	6.862	0.0

Onderdeel....:

KNIKSTABILITEIT

Staafl	l _{sys} [m]	Classif. y sterke as	l _{knik,y} [m]	Extra		l _{knik,z} [m]	Extra	
				aanp. y [kN]	Classif. z zwakke as		aanp. z [kN]	
176	7.071	Geschoord	7.071	0.0	Geschoord	7.071	0.0	0.0
177	7.071	Geschoord	7.071	0.0	Geschoord	7.071	0.0	0.0
178	7.071	Geschoord	7.071	0.0	Geschoord	7.071	0.0	0.0
179	6.862	Geschoord	6.862	0.0	Geschoord	6.862	0.0	0.0
180	6.862	Geschoord	6.862	0.0	Geschoord	6.862	0.0	0.0

* Door gebruiker gedefinieerde kniklengte

KIPSTABILITEIT

Staafl	Plts. aangr.		l gaffel [m]	Kipsteunafstanden [m]
1	1.0*h	boven:	4.70	4.700
		onder:		4.700
2	1.0*h	boven:	5.00	5.000
		onder:		5.000
3	1.0*h	boven:	5.00	5.000
		onder:		5.000
4	1.0*h	boven:	5.00	5.000
		onder:		5.000
5	1.0*h	boven:	4.70	4.7
		onder:		4.7
6	1.0*h	boven:	5.00	5.000
		onder:		5.000
7	1.0*h	boven:	5.00	5.000
		onder:		5.000
8	1.0*h	boven:	5.00	5.000
		onder:		5.000
9	1.0*h	boven:	4.70	4.700
		onder:		4.700
10	1.0*h	boven:	4.70	4.700
		onder:		4.700
11	1.0*h	boven:	4.70	4.700
		onder:		4.700
12	1.0*h	boven:	4.70	4.700
		onder:		4.700
13	1.0*h	boven:	4.70	4.700
		onder:		4.700
14	1.0*h	boven:	4.70	4.700
		onder:		4.700
15	1.0*h	boven:	4.70	4.700
		onder:		4.700
16	1.0*h	boven:	5.00	5.000
		onder:		5.000
17	1.0*h	boven:	5.00	5.000
		onder:		5.000
18	1.0*h	boven:	5.00	5.000
		onder:		5.000
19	1.0*h	boven:	5.00	5.000
		onder:		5.000
20	1.0*h	boven:	5.00	5.000
		onder:		5.000
21	1.0*h	boven:	5.00	5.000
		onder:		5.000
22	1.0*h	boven:	4.70	4.7
		onder:		4.7
23	0.0*h	boven:	5.00	5.000
		onder:		5.000
24	0.0*h	boven:	5.00	5.000
		onder:		5.000
25	0.0*h	boven:	5.00	5.000
		onder:		5.000

Onderdeel....:

KIPSTABILITEIT

Staaft	Plts. aangr.		1 gaffel [m]	Kipsteunafstanden [m]
26	0.0*h	boven:	5.00	5.000
		onder:		5.000
27	0.0*h	boven:	5.00	5.000
		onder:		5.000
28	0.0*h	boven:	5.00	5.000
		onder:		5.000
29	0.0*h	boven:	4.70	4.7
		onder:		4.7
30	1.0*h	boven:	4.70	4.700
		onder:		4.700
31	1.0*h	boven:	4.70	4.700
		onder:		4.700
32	1.0*h	boven:	5.00	5.000
		onder:		5.000
33	1.0*h	boven:	5.00	5.000
		onder:		5.000
34	1.0*h	boven:	5.00	5.000
		onder:		5.000
35	1.0*h	boven:	5.00	5.000
		onder:		5.000
36	1.0*h	boven:	5.00	5.000
		onder:		5.000
37	1.0*h	boven:	5.00	5.000
		onder:		5.000
38	1.0*h	boven:	5.00	5.000
		onder:		5.000
39	1.0*h	boven:	5.00	5.000
		onder:		5.000
40	1.0*h	boven:	5.00	5.000
		onder:		5.000
41	1.0*h	boven:	5.00	5.000
		onder:		5.000
42	1.0*h	boven:	5.00	5.000
		onder:		5.000
43	1.0*h	boven:	5.00	5.000
		onder:		5.000
44	1.0*h	boven:	4.70	4.7
		onder:		4.7
45	1.0*h	boven:	5.00	5.000
		onder:		5.000
46	1.0*h	boven:	5.00	5.000
		onder:		5.000
47	1.0*h	boven:	5.00	5.000
		onder:		5.000
48	1.0*h	boven:	5.00	5.000
		onder:		5.000
49	1.0*h	boven:	5.00	5.000
		onder:		5.000
50	1.0*h	boven:	4.70	4.7
		onder:		4.7
51	1.0*h	boven:	4.70	4.700
		onder:		4.700
52	1.0*h	boven:	5.00	5.000
		onder:		5.000
53	1.0*h	boven:	5.00	5.000
		onder:		5.000
54	1.0*h	boven:	5.00	5.000
		onder:		5.000
55	1.0*h	boven:	5.00	5.000
		onder:		5.000

Onderdeel....:

KIPSTABILITEIT

Staaft	Plts. aangr.		1 gaffel [m]	Kipsteunafstanden [m]
56	1.0*h	boven:	5.00	5.000
		onder:		5.000
57	0.0*h	boven:	5.00	5.000
		onder:		5.000
58	0.0*h	boven:	4.70	4.700
		onder:		4.700
59	0.0*h	boven:	5.00	5.000
		onder:		5.000
60	0.0*h	boven:	4.70	4.700
		onder:		4.700
61	0.0*h	boven:	5.00	5.000
		onder:		5.000

62	0.0*h	boven:	4.70	4.700
		onder:		4.700
63	0.0*h	boven:	4.70	4.700
		onder:		4.700
64	0.0*h	boven:	4.70	4.700
		onder:		4.700
65	0.0*h	boven:	5.00	5.000
		onder:		5.000
66	0.0*h	boven:	5.00	5.000
		onder:		5.000
67	0.0*h	boven:	4.70	4.700
		onder:		4.700
68	1.0*h	boven:	5.00	5.000
		onder:		5.000
69	1.0*h	boven:	5.00	5.000
		onder:		5.000
70	1.0*h	boven:	5.00	5.000
		onder:		5.000
71	1.0*h	boven:	5.00	5.000
		onder:		5.000
72	1.0*h	boven:	5.00	5.000
		onder:		5.000
73	1.0*h	boven:	5.00	5.000
		onder:		5.000
74	1.0*h	boven:	5.00	5.000
		onder:		5.000
75	1.0*h	boven:	5.00	5.000
		onder:		5.000
76	1.0*h	boven:	5.00	5.000
		onder:		5.000
77	1.0*h	boven:	5.00	5.000
		onder:		5.000
78	1.0*h	boven:	5.00	5.000
		onder:		5.000
79	1.0*h	boven:	5.00	5.000
		onder:		5.000
80	1.0*h	boven:	5.00	5.000
		onder:		5.000
81	1.0*h	boven:	5.00	5.000
		onder:		5.000
82	1.0*h	boven:	5.00	5.000
		onder:		5.000
83	1.0*h	boven:	5.00	5.000
		onder:		5.000
84	1.0*h	boven:	5.00	5.000
		onder:		5.000
85	1.0*h	boven:	5.00	5.000
		onder:		5.000

Onderdeel....:

KIPSTABILITEIT

Staaft	Plts. aangr.		1 gaffel [m]	Kipsteunafstanden [m]
86	1.0*h	boven:	5.00	5.000
		onder:		5.000
87	1.0*h	boven:	5.00	5.000
		onder:		5.000
88	1.0*h	boven:	5.00	5.000
		onder:		5.000
89	1.0*h	boven:	5.00	5.000
		onder:		5.000
90	1.0*h	boven:	5.00	5.000
		onder:		5.000
91	1.0*h	boven:	4.70	4.7
		onder:		4.7
92	1.0*h	boven:	4.70	4.7
		onder:		4.7
93	1.0*h	boven:	4.70	4.7
		onder:		4.7
94	1.0*h	boven:	4.70	4.7
		onder:		4.7
95	1.0*h	boven:	4.70	4.7
		onder:		4.7
96	1.0*h	boven:	5.00	5.000
		onder:		5.000
97	1.0*h	boven:	5.00	5.000
		onder:		5.000
98	1.0*h	boven:	5.00	5.000
		onder:		5.000
99	0.0*h	boven:	5.00	5.000
		onder:		5.000
100	0.0*h	boven:	5.00	5.000

		onder:	5.000	
101	0.0*h	boven:	5.00	5.000
		onder:		5.000
102	0.0*h	boven:	5.00	5.000
		onder:		5.000
103	0.0*h	boven:	5.00	5.000
		onder:		5.000
104	0.0*h	boven:	5.00	5.000
		onder:		5.000
105	0.0*h	boven:	5.00	5.000
		onder:		5.000
106	0.0*h	boven:	5.00	5.000
		onder:		5.000
107	0.0*h	boven:	5.00	5.000
		onder:		5.000
108	0.0*h	boven:	5.00	5.000
		onder:		5.000
109	0.0*h	boven:	5.00	5.000
		onder:		5.000
110	0.0*h	boven:	5.00	5.000
		onder:		5.000
111	0.0*h	boven:	5.00	5.000
		onder:		5.000
112	0.0*h	boven:	5.00	5.000
		onder:		5.000
113	0.0*h	boven:	5.00	5.000
		onder:		5.000
114	0.0*h	boven:	5.00	5.000
		onder:		5.000
115	0.0*h	boven:	5.00	5.000
		onder:		5.000

Onderdeel....:

KIPSTABILITEIT

Staafl	Plts. aangr.		l gaffel [m]	Kipsteunafstanden [m]
116	0.0*h	boven:	5.00	5.000
		onder:		5.000
117	0.0*h	boven:	5.00	5.000
		onder:		5.000
118	0.0*h	boven:	5.00	5.000
		onder:		5.000
119	0.0*h	boven:	5.00	5.000
		onder:		5.000
120	0.0*h	boven:	5.00	5.000
		onder:		5.000
121	0.0*h	boven:	5.00	5.000
		onder:		5.000
122	0.0*h	boven:	5.00	5.000
		onder:		5.000
123	0.0*h	boven:	5.00	5.000
		onder:		5.000
124	1.0*h	boven:	4.70	4.7
		onder:		4.7
125	1.0*h	boven:	5.00	5.000
		onder:		5.000
126	0.0*h	boven:	4.70	4.7
		onder:		4.7
127	1.0*h	boven:	5.00	5.000
		onder:		5.000
128	0.0*h	boven:	4.70	4.7
		onder:		4.7
129	1.0*h	boven:	5.00	5.000
		onder:		5.000
130	0.0*h	boven:	4.70	4.7
		onder:		4.7
131	1.0*h	boven:	5.00	5.000
		onder:		5.000
132	0.0*h	boven:	4.70	4.7
		onder:		4.7
133	1.0*h	boven:	5.00	5.000
		onder:		5.000
134	0.0*h	boven:	4.70	4.7
		onder:		4.7
135	1.0*h	boven:	4.70	4.7
		onder:		4.7
136	1.0*h	boven:	6.65	6.647
		onder:		6.647
137	1.0*h	boven:	7.07	7.071
		onder:		7.071
138	1.0*h	boven:	7.07	7.071

		onder:	7.071
139	1.0*h	boven:	7.07 7.071
		onder:	7.071
140	1.0*h	boven:	7.07 7.071
		onder:	7.071
141	1.0*h	boven:	7.07 7.071
		onder:	7.071
142	1.0*h	boven:	7.07 7.071
		onder:	7.071
143	1.0*h	boven:	6.65 6.6468
		onder:	6.6468
144	0.0*h	boven:	7.07 7.071
		onder:	7.071
145	0.0*h	boven:	7.07 7.071
		onder:	7.071

Onderdeel....:

KIPSTABILITEIT

Staaft Plts. l gaffel Kipsteunafstanden
aangr. [m] [m]

146	0.0*h	boven:	7.07 7.071
		onder:	7.071
147	1.0*h	boven:	5.00 5.000
		onder:	5.000
148	0.0*h	boven:	7.07 7.071
		onder:	7.071
149	0.0*h	boven:	6.65 6.647
		onder:	6.647
150	0.0*h	boven:	7.07 7.071
		onder:	7.071
151	0.0*h	boven:	7.07 7.071
		onder:	7.071
152	0.0*h	boven:	6.65 6.647
		onder:	6.647
153	1.0*h	boven:	6.86 6.862
		onder:	6.862
154	1.0*h	boven:	7.07 7.071
		onder:	7.071
155	1.0*h	boven:	7.07 7.071
		onder:	7.071
156	1.0*h	boven:	6.86 6.862
		onder:	6.862
157	1.0*h	boven:	6.86 6.862
		onder:	6.862
158	1.0*h	boven:	7.07 7.071
		onder:	7.071
159	1.0*h	boven:	7.07 7.071
		onder:	7.071
160	1.0*h	boven:	6.86 6.862
		onder:	6.862
161	1.0*h	boven:	7.07 7.071
		onder:	7.071
162	1.0*h	boven:	6.86 6.862
		onder:	6.862
163	0.0*h	boven:	6.86 6.862
		onder:	6.862
164	0.0*h	boven:	7.07 7.071
		onder:	7.071
165	0.0*h	boven:	7.07 7.071
		onder:	7.071
166	0.0*h	boven:	6.86 6.862
		onder:	6.862
167	1.0*h	boven:	4.70 4.700
		onder:	4.700
168	1.0*h	boven:	5.00 5.000
		onder:	5.000
169	1.0*h	boven:	5.00 5.000
		onder:	5.000
170	1.0*h	boven:	5.00 5.000
		onder:	5.000
171	1.0*h	boven:	5.00 5.000
		onder:	5.000
172	1.0*h	boven:	5.00 5.000
		onder:	5.000
173	1.0*h	boven:	5.00 5.000
		onder:	5.000
174	1.0*h	boven:	4.70 4.7
		onder:	4.7
175	0.0*h	boven:	6.86 6.862
		onder:	6.862

Onderdeel....:

KIPSTABILITEIT

Staafl	Plts. aangr.		l gaffel [m]	Kipsteunafstanden [m]
176	0.0*h	boven:	7.07	7.071
		onder:		7.071
177	0.0*h	boven:	7.07	7.0711
		onder:		7.0711
178	0.0*h	boven:	7.07	7.071
		onder:		7.071
179	1.0*h	boven:	6.86	6.862
		onder:		6.862
180	1.0*h	boven:	6.86	6.862
		onder:		6.862

TOETSING SPANNINGEN

Staafl	P/M	BC	Sit	Kl	Plaats	Norm	Artikel	Formule	Hoogste toetsing U.C. [N/mm ²]	Opm.
1	2	1	2	1	Staafl	EN3-1-1	6.3.2	(6.54)	0.038	9
2	2	1	2	1	Begin	EN3-1-1	6.2.10	(6.45+6.31y)	0.038	9
3	2	1	3	1	Staafl	EN3-1-1	6.3.2	(6.54)	0.046	11
4	2	2	2	1	Einde	EN3-1-1	6.2.10	(6.45+6.31y)	0.024	6
5	2	2	2	1	Begin	EN3-1-1	6.2.10	(6.45+6.31y)	0.024	6
6	2	1	3	1	Staafl	EN3-1-1	6.3.2	(6.54)	0.136	32
7	2	1	3	1	Begin	EN3-1-1	6.2.10	(6.45+6.31y)	0.082	19
8	2	1	3	1	Staafl	EN3-1-1	6.3.3	(6.62)	0.167	39
9	2	2	3	1	Staafl	EN3-1-1	6.3.2	(6.54)	0.028	7
10	2	2	3	1	Staafl	EN3-1-1	6.3.2	(6.54)	0.017	4
11	2	2	3	3	Staafl	EN3-1-1	6.3.3	(6.62)	0.136	32
12	2	2	3	1	Staafl	EN3-1-1	6.3.2	(6.54)	0.027	6
13	2	2	3	1	Staafl	EN3-1-1	6.3.2	(6.54)	0.030	7
14	2	1	3	1	Staafl	EN3-1-1	6.3.2	(6.54)	0.036	8
15	4	1	3	1	Staafl	EN3-1-1	6.3.1.1	(6.46y)	0.220	52
16	4	1	3	1	Staafl	EN3-1-1	6.3.1.1	(6.46y)	0.223	52
17	4	1	3	1	Staafl	EN3-1-1	6.3.1.1	(6.46y)	0.217	51
18	4	1	3	1	Staafl	EN3-1-1	6.3.1.1	(6.46y)	0.215	50
19	4	2	3	1	Staafl	EN3-1-1	6.3.1.1	(6.46y)	0.273	64
20	4	2	3	1	Staafl	EN3-1-1	6.3.1.1	(6.46y)	0.267	63
21	4	2	3	1	Staafl	EN3-1-1	6.3.1.1	(6.46y)	0.260	61
22	4	2	3	1	Staafl	EN3-1-1	6.3.1.1	(6.46y)	0.243	57
23	4	2	2	1	Begin	EN3-1-1	6.2.3	(6.5)	0.011	3
24	4	2	2	1	Begin	EN3-1-1	6.2.3	(6.5)	0.015	4
25	4	2	2	1	Begin	EN3-1-1	6.2.3	(6.5)	0.017	4
26	4	2	2	1	Staafl	EN3-1-1	6.3.1.1	(6.46y)	0.273	64
27	4	2	2	1	Staafl	EN3-1-1	6.3.1.1	(6.46y)	0.267	63
28	4	2	2	1	Staafl	EN3-1-1	6.3.1.1	(6.46y)	0.260	61
29	4	2	2	1	Staafl	EN3-1-1	6.3.1.1	(6.46y)	0.243	57
30	1	1	2	1	Staafl	EN3-1-1	6.3.3	(6.62)	0.244	57
31	3	2	2	1	Begin	EN3-1-1	6.2.3	(6.5)	0.029	7
32	3	1	2	1	Begin	EN3-1-1	6.2.3	(6.5)	0.023	5
33	2	2	3	1	Begin	EN3-1-1	6.2.8	(6.30)	0.028	7
34	3	1	2	1	Begin	EN3-1-1	6.2.3	(6.5)	0.016	4
35	2	1	2	1	Staafl	EN3-1-1	6.3.2	(6.54)	0.019	4
36	3	2	3	1	Staafl	EN3-1-1	6.3.1.1	(6.46y)	0.256	60
37	2	2	3	3	Staafl	EN3-1-1	6.3.3	(6.62)	0.145	34
38	3	2	3	1	Staafl	EN3-1-1	6.3.1.1	(6.46y)	0.285	67
39	2	2	3	1	Begin	EN3-1-1	6.2.8	(6.30)	0.027	6
40	3	2	3	1	Staafl	EN3-1-1	6.3.1.1	(6.46y)	0.310	73
41	2	2	3	1	Begin	EN3-1-1	6.2.8	(6.30)	0.030	7
42	3	2	3	1	Staafl	EN3-1-1	6.3.1.1	(6.46y)	0.346	81
43	2	1	2	1	Staafl	EN3-1-1	6.3.2	(6.54)	0.061	14

Onderdeel.....:

TOETSING SPANNINGEN

Staafl	P/M	BC	Sit	Kl	Plaats	Norm	Artikel	Formule	Hoogste toetsing U.C. [N/mm ²]	Opm.
44	3	2	3	1	Staafl	EN3-1-1	6.3.1.1	(6.46y)	0.353	83
45	1	1	2	1	Staafl	EN3-1-1	6.3.3	(6.62)	0.272	64
46	2	1	3	1	Staafl	EN3-1-1	6.3.2	(6.54)	0.022	5
47	2	1	3	1	Staafl	EN3-1-1	6.3.2	(6.54)	0.081	19
48	2	1	3	1	Staafl	EN3-1-1	6.3.3	(6.62)	0.110	26
49	2	1	3	1	Staafl	EN3-1-1	6.3.3	(6.62)	0.074	17
50	2	2	2	1	Begin	EN3-1-1	6.2.8	(6.30)	0.027	6
51	3	2	3	1	Begin	EN3-1-1	6.2.3	(6.5)	0.031	7
52	3	2	1	1	Begin	EN3-1-1	6.2.3	(6.5)	0.029	7
53	3	2	3	1	Staafl	EN3-1-1	6.3.1.1	(6.46y)	0.232	55
54	2	1	2	1	Begin	EN3-1-1	6.2.10	(6.45+6.31y)	0.019	4
55	3	2	2	1	Staafl	EN3-1-1	6.3.1.1	(6.46y)	0.233	55

56	2	2	3	3	Staaaf	EN3-1-1	6.3.3	(6.62)	0.127	30
57	3	2	2	1	Staaaf	EN3-1-1	6.3.1.1	(6.46y)	0.195	46
58	3	2	2	1	Begin	EN3-1-1	6.2.3	(6.5)	0.031	7
59	3	1	3	1	Staaaf	EN3-1-1	6.3.1.1	(6.46y)	0.606	143
60	3	1	3	1	Staaaf	EN3-1-1	6.3.1.1	(6.46y)	0.769	181
61	3	2	3	1	Staaaf	EN3-1-1	6.3.1.1	(6.46y)	0.196	46
62	3	2	3	1	Begin	EN3-1-1	6.2.3	(6.5)	0.031	7
63	3	2	2	1	Begin	EN3-1-1	6.2.3	(6.5)	0.031	7
64	3	2	3	1	Begin	EN3-1-1	6.2.3	(6.5)	0.028	7
65	3	2	3	1	Begin	EN3-1-1	6.2.3	(6.5)	0.019	5
66	3	2	2	1	Begin	EN3-1-1	6.2.3	(6.5)	0.029	7
67	4	1	2	1	Begin	EN3-1-1	6.2.10	(6.45+6.31y)	0.057	13
68	2	1	2	1	Begin	EN3-1-1	6.2.8	(6.30)	0.026	6
69	2	1	3	1	Begin	EN3-1-1	6.2.10	(6.45+6.31y)	0.028	7
70	2	1	2	1	Staaaf	EN3-1-1	6.3.2	(6.54)	0.067	16
71	2	1	3	1	Staaaf	EN3-1-1	6.3.2	(6.54)	0.049	11
72	2	2	3	3	Staaaf	EN3-1-1	6.3.3	(6.62)	0.129	30
73	2	2	2	1	Staaaf	EN3-1-1	6.3.2	(6.54)	0.027	6
74	2	1	2	1	Begin	EN3-1-1	6.2.10	(6.45+6.31y)	0.024	6
75	2	1	2	1	Staaaf	EN3-1-1	6.3.2	(6.54)	0.069	16
76	2	1	3	1	Staaaf	EN3-1-1	6.3.3	(6.62)	0.063	15
77	2	2	2	3	Staaaf	EN3-1-1	6.3.3	(6.62)	0.129	30
78	2	1	2	3	Staaaf	EN3-1-1	6.3.3	(6.62)	0.042	10
79	2	2	3	1	Begin	EN3-1-1	6.2.10	(6.45+6.31y)	0.019	4
80	2	1	2	1	Staaaf	EN3-1-1	6.3.3	(6.62)	0.093	22
81	2	1	3	1	Staaaf	EN3-1-1	6.3.3	(6.62)	0.039	9
82	2	2	2	3	Staaaf	EN3-1-1	6.3.3	(6.62)	0.127	30
83	2	1	2	3	Staaaf	EN3-1-1	6.3.3	(6.62)	0.050	12
84	2	1	2	1	Begin	EN3-1-1	6.2.8	(6.30)	0.016	4
85	2	1	2	1	Begin	EN3-1-1	6.2.8	(6.30)	0.051	12
86	2	1	2	3	Staaaf	EN3-1-1	6.3.3	(6.62)	0.032	8
87	2	2	2	3	Staaaf	EN3-1-1	6.3.3	(6.62)	0.145	34
88	2	1	2	3	Staaaf	EN3-1-1	6.3.3	(6.62)	0.050	12
89	2	2	1	1	Staaaf	EN3-1-1	6.3.2	(6.54)	0.029	7
90	2	2	1	1	Staaaf	EN3-1-1	6.3.2	(6.54)	0.025	6
91	2	2	2	1	Begin	EN3-1-1	6.2.8	(6.30)	0.017	4
92	2	2	2	3	Staaaf	EN3-1-1	6.3.3	(6.62)	0.135	32
93	2	2	2	1	Begin	EN3-1-1	6.2.8	(6.30)	0.026	6
94	2	2	1	1	Begin	EN3-1-1	6.2.8	(6.30)	0.029	7
95	2	2	1	1	Begin	EN3-1-1	6.2.8	(6.30)	0.025	6
96	3	2	2	1	Staaaf	EN3-1-1	6.3.1.1	(6.46y)	0.224	53
97	3	2	2	1	Staaaf	EN3-1-1	6.3.1.1	(6.46y)	0.225	53

Onderdeel.....:

TOETSING SPANNINGEN

nr.	P/M	BC	Sit	Kl	Plaats	Norm	Artikel	Formule	Hoogste toetsing U.C. [N/mm ²]	Opm.
98	3	2	3	1	Staaaf	EN3-1-1	6.3.1.1	(6.46y)	0.417	98
99	3	2	2	1	Staaaf	EN3-1-1	6.3.1.1	(6.46y)	0.201	47
100	3	2	2	1	Staaaf	EN3-1-1	6.3.1.1	(6.46y)	0.196	46
101	3	2	2	1	Staaaf	EN3-1-1	6.3.1.1	(6.46y)	0.191	45
102	3	2	2	1	Staaaf	EN3-1-1	6.3.1.1	(6.46y)	0.402	94
103	3	2	2	1	Staaaf	EN3-1-1	6.3.1.1	(6.46y)	0.402	94
104	3	1	3	1	Staaaf	EN3-1-1	6.3.1.1	(6.46y)	0.472	111
105	3	1	3	1	Staaaf	EN3-1-1	6.3.1.1	(6.46y)	0.394	93
106	3	2	1	1	Staaaf	EN3-1-1	6.3.1.1	(6.46y)	0.333	78
107	3	2	2	1	Staaaf	EN3-1-1	6.3.1.1	(6.46y)	0.367	86
108	3	1	2	1	Staaaf	EN3-1-1	6.3.1.1	(6.46y)	0.520	122
109	3	2	3	1	Staaaf	EN3-1-1	6.3.1.1	(6.46y)	0.202	48
110	3	2	3	1	Staaaf	EN3-1-1	6.3.1.1	(6.46y)	0.196	46
111	3	2	3	1	Staaaf	EN3-1-1	6.3.1.1	(6.46y)	0.191	45
112	3	2	1	1	Staaaf	EN3-1-1	6.3.1.1	(6.46y)	0.402	94
113	3	2	3	1	Staaaf	EN3-1-1	6.3.1.1	(6.46y)	0.402	94
114	3	2	3	1	Staaaf	EN3-1-1	6.3.1.1	(6.46y)	0.232	55
115	3	2	3	1	Staaaf	EN3-1-1	6.3.1.1	(6.46y)	0.233	55
116	3	2	3	1	Staaaf	EN3-1-1	6.3.1.1	(6.46y)	0.224	53
117	3	2	1	1	Staaaf	EN3-1-1	6.3.1.1	(6.46y)	0.225	53
118	3	2	3	1	Staaaf	EN3-1-1	6.3.1.1	(6.46y)	0.416	98
119	3				Staaaf is onbelast					57
120	3	2	2	1	Staaaf	EN3-1-1	6.3.1.1	(6.46y)	0.256	60
121	3	2	2	1	Staaaf	EN3-1-1	6.3.1.1	(6.46y)	0.285	67
122	3	2	2	1	Staaaf	EN3-1-1	6.3.1.1	(6.46y)	0.310	73
123	3	2	2	1	Staaaf	EN3-1-1	6.3.1.1	(6.46y)	0.345	81
124	3	1	2	1	Staaaf	EN3-1-1	6.3.1.1	(6.46y)	0.373	88
125	1	1	2	1	Staaaf	EN3-1-1	6.3.3	(6.62)	0.476	112

126	3	2	3	1	Staaft	EN3-1-1	6.3.1.1	(6.46y)	0.363	85	
127	1	1	2	1	Staaft	EN3-1-1	6.3.3	(6.62)	0.477	112	
128	3	1	2	1	Staaft	EN3-1-1	6.3.1.1	(6.46y)	0.612	144	
129	1	2	3	1	Staaft	EN3-1-1	6.3.3	(6.62)	0.249	59	
130	3	2	3	1	Staaft	EN3-1-1	6.3.1.1	(6.46y)	0.363	85	
131	1	2	3	1	Staaft	EN3-1-1	6.3.3	(6.62)	0.247	58	
132	3	2	3	1	Staaft	EN3-1-1	6.3.1.1	(6.46y)	0.364	86	
133	1	2	2	1	Staaft	EN3-1-1	6.3.3	(6.62)	0.251	59	
134	3	2	2	1	Staaft	EN3-1-1	6.3.1.1	(6.46y)	0.353	83	
135	1	2	2	1	Staaft	EN3-1-1	6.3.3	(6.62)	0.232	54	
136	5	1	2	3	Begin	EN3-1-1	6.2.3	(6.5)	0.229	54	
137	5	1	2	3	Begin	EN3-1-1	6.2.3	(6.5)	0.197	46	
138	5	1	2	3	Begin	EN3-1-1	6.2.3	(6.5)	0.168	39	
139	5	1	2	3	Begin	EN3-1-1	6.2.3	(6.5)	0.086	20	
140	5	2	2	3	Begin	EN3-1-1	6.2.3	(6.5)	0.025	6	
141	5	2	2	3	Begin	EN3-1-1	6.2.3	(6.5)	0.106	25	
142	5	2	2	3	Begin	EN3-1-1	6.2.3	(6.5)	0.178	42	
143	5	2	2	3	Begin	EN3-1-1	6.2.3	(6.5)	0.184	43	
144	5	1	3	3	Begin	EN3-1-1	6.2.3	(6.5)	0.029	7	
145	5	1	3	3	Begin	EN3-1-1	6.2.3	(6.5)	0.038	9	
146	5	1	2	3	Begin	EN3-1-1	6.2.3	(6.5)	0.035	8	
147	2	2	2	1	Staaft	EN3-1-1	6.3.2	(6.54)	0.027	6	
148	5				Staaft is onbelast						57
149	5				Staaft is onbelast						57
150	5	2	3	3	Begin	EN3-1-1	6.2.3	(6.5)	0.105	25	
151	5	2	3	3	Begin	EN3-1-1	6.2.3	(6.5)	0.178	42	

Onderdeel....:

TOETSING SPANNINGEN

Staaft	P/M	BC	Sit	Kl	Plaats	Norm	Artikel	Formule	Hoogste toetsing	Opm.
nr.									U.C. [N/mm ²]	
152	5	1	3	3	Begin	EN3-1-1	6.2.3	(6.5)	0.184	43
153	5	1	2	3	Begin	EN3-1-1	6.2.3	(6.5)	0.303	71
154	5	1	2	3	Begin	EN3-1-1	6.2.3	(6.5)	0.183	43
155	5	2	3	3	Begin	EN3-1-1	6.2.3	(6.5)	0.247	58
156	5	2	3	3	Begin	EN3-1-1	6.2.3	(6.5)	0.324	76
157	5	2	2	3	Begin	EN3-1-1	6.2.3	(6.5)	0.042	10
158	5	2	2	3	Begin	EN3-1-1	6.2.3	(6.5)	0.138	33
159	5	2	2	3	Begin	EN3-1-1	6.2.3	(6.5)	0.247	58
160	5	2	2	3	Begin	EN3-1-1	6.2.3	(6.5)	0.324	76
161	5				Staaft is onbelast					57
162	5				Staaft is onbelast					57
163	5	1	3	3	Begin	EN3-1-1	6.2.3	(6.5)	0.241	57
164	5	1	3	3	Begin	EN3-1-1	6.2.3	(6.5)	0.162	38
165	5	1	3	3	Begin	EN3-1-1	6.2.3	(6.5)	0.162	38
166	5	1	2	3	Begin	EN3-1-1	6.2.3	(6.5)	0.075	18
167	1	1	3	1	Staaft	EN3-1-1	6.3.3	(6.62)	0.295	69
168	1	1	3	1	Staaft	EN3-1-1	6.3.3	(6.62)	0.320	75
169	1	1	3	1	Staaft	EN3-1-1	6.3.3	(6.62)	0.331	78
170	1	1	3	1	Staaft	EN3-1-1	6.3.3	(6.62)	0.355	83
171	1	1	3	1	Begin	EN3-1-1	6.2.10	(6.45+6.31y)	0.065	15
172	1	1	3	1	Begin	EN3-1-1	6.2.10	(6.45+6.31y)	0.040	9
173	1	2	2	1	Staaft	EN3-1-1	6.3.2	(6.54)	0.013	3
174	1	1	2	1	Staaft	EN3-1-1	6.3.2	(6.54)	0.041	10
175	5	1	3	3	Begin	EN3-1-1	6.2.3	(6.5)	0.148	35
176	5	1	3	3	Begin	EN3-1-1	6.2.3	(6.5)	0.104	24
177	5				Staaft is onbelast					57
178	5				Staaft is onbelast					57
179	5				Staaft is onbelast					57
180	5				Staaft is onbelast					57

Opmerkingen:

[57] Staaft is (nagenoeg) onbelast.

TOETSING DOORBUIGING

Staaft	Soort	Mtg	Lengte	Overst	Zeeg	u _{tot}	BC	Sit	u	Toelaatbaar	
			[m]	I	J	[mm]			[mm]	[mm] *1	
1	Vloer	ss	4.70	N	N	0.0	-3.4	4	1	Eind	-3.4 ±37.6 2*0.004
2	Vloer	ss	5.00	N	N	0.0	-2.1	4	1	Eind	-2.1 ±40.0 2*0.004
3	Vloer	ss	5.00	N	N	0.0	-1.7	3	1	Eind	-1.7 ±40.0 2*0.004
4	Vloer	ss	5.00	N	N	0.0	-2.0	4	1	Eind	-2.0 ±40.0 2*0.004
5	Vloer	ss	4.70	N	N	0.0	-3.3	4	1	Eind	-3.3 ±37.6 2*0.004
6	Vloer	ss	5.00	N	N	0.0	2.6	3	1	Eind	2.6 ±40.0 2*0.004
							-0.5	4	1	Eind	-0.5
7	Vloer	ss	5.00	N	N	0.0	-0.9	4	1	Eind	-0.9 ±40.0 2*0.004
8	Vloer	ss	5.00	N	N	0.0	3.2	3	1	Eind	3.2 ±40.0 2*0.004
							-0.6	4	1	Eind	-0.6
9	Vloer	ss	4.70	N	N	0.0	-3.3	4	1	Eind	-3.3 ±37.6 2*0.004
10	Vloer	ss	4.70	N	N	0.0	-3.4	4	1	Eind	-3.4 ±37.6 2*0.004

11	Vloer	ss	4.70	N	N	0.0	-3.9	4	1	Eind	-3.9	±37.6	2*0.004
12	Vloer	ss	4.70	N	N	0.0	-3.7	4	1	Eind	-3.7	±37.6	2*0.004
13	Vloer	ss	4.70	N	N	0.0	-3.6	4	1	Eind	-3.6	±37.6	2*0.004
14	Vloer	ss	4.70	N	N	0.0	-3.5	4	1	Eind	-3.5	±37.6	2*0.004
30	Dak	ss	4.70	N	N	0.0	-3.6	4	1	Eind	-3.6	-37.6	2*0.004
33	Vloer	ss	5.00	N	N	0.0	-2.0	4	1	Eind	-2.0	±40.0	2*0.004
35	Vloer	ss	5.00	N	N	0.0	-2.5	4	1	Eind	-2.5	±40.0	2*0.004
37	Vloer	ss	5.00	N	N	0.0	-2.4	4	1	Eind	-2.4	±40.0	2*0.004
39	Vloer	ss	5.00	N	N	0.0	-2.3	4	1	Eind	-2.3	±40.0	2*0.004
41	Vloer	ss	5.00	N	N	0.0	-2.2	4	1	Eind	-2.2	±40.0	2*0.004

Onderdeel.....:

TOETSING DOORBUIGING

Staaft	Soort	Mtg	Lengte [m]	Overst I	Overst J	Zeeg [mm]	u_{tot} [mm]	BC	Sit	u [mm]	Toelaatbaar [mm]	*1	
43	Vloer	ss	5.00	N	N	0.0	-2.3	4	1	Eind	-2.3	±40.0	2*0.004
45	Dak	ss	5.00	N	N	0.0	-2.3	4	1	Eind	-2.3	-40.0	2*0.004
46	Vloer	ss	5.00	N	N	0.0	-1.4	3	1	Eind	-1.4	±40.0	2*0.004
47	Vloer	ss	5.00	N	N	0.0	1.8	3	1	Eind	1.8	±40.0	2*0.004
48	Vloer	ss	5.00	N	N	0.0	-0.5	4	1	Eind	-0.5		
							1.9	3	1	Eind	1.9	±40.0	2*0.004
							-0.5	4	1	Eind	-0.5		
49	Vloer	ss	5.00	N	N	0.0	-1.4	4	1	Eind	-1.4	±40.0	2*0.004
50	Vloer	ss	4.70	N	N	0.0	-3.3	4	1	Eind	-3.3	±37.6	2*0.004
54	Vloer	ss	5.00	N	N	0.0	-1.3	4	1	Eind	-1.3	±40.0	2*0.004
56	Vloer	ss	5.00	N	N	0.0	-1.3	4	1	Eind	-1.3	±40.0	2*0.004
68	Vloer	ss	5.00	N	N	0.0	-1.2	4	1	Eind	-1.2	±40.0	2*0.004
69	Vloer	ss	5.00	N	N	0.0	-1.5	4	1	Eind	-1.5	±40.0	2*0.004
70	Vloer	ss	5.00	N	N	0.0	-1.5	4	1	Eind	-1.5	±40.0	2*0.004
71	Vloer	ss	5.00	N	N	0.0	1.3	3	1	Eind	1.3	±40.0	2*0.004
							-0.5	4	1	Eind	-0.5		
72	Vloer	ss	5.00	N	N	0.0	-0.6	3	1	Eind	-0.6	±40.0	2*0.004
73	Vloer	ss	5.00	N	N	0.0	-0.7	4	1	Eind	-0.7	±40.0	2*0.004
74	Vloer	ss	5.00	N	N	0.0	-0.7	4	1	Eind	-0.7	±40.0	2*0.004
75	Vloer	ss	5.00	N	N	0.0	-0.7	3	1	Eind	-0.7	±40.0	2*0.004
76	Vloer	ss	5.00	N	N	0.0	1.0	3	1	Eind	1.0	±40.0	2*0.004
							-0.5	4	1	Eind	-0.5		
77	Vloer	ss	5.00	N	N	0.0	-0.5	4	1	Eind	-0.5	±40.0	2*0.004
78	Vloer	ss	5.00	N	N	0.0	-0.7	4	1	Eind	-0.7	±40.0	2*0.004
79	Vloer	ss	5.00	N	N	0.0	-0.7	4	1	Eind	-0.7	±40.0	2*0.004
80	Vloer	ss	5.00	N	N	0.0	-1.6	3	1	Eind	-1.6	±40.0	2*0.004
81	Vloer	ss	5.00	N	N	0.0	-1.3	4	1	Eind	-1.3	±40.0	2*0.004
82	Vloer	ss	5.00	N	N	0.0	-1.3	4	1	Eind	-1.3	±40.0	2*0.004
83	Vloer	ss	5.00	N	N	0.0	-1.2	4	1	Eind	-1.2	±40.0	2*0.004
84	Vloer	ss	5.00	N	N	0.0	-1.5	4	1	Eind	-1.5	±40.0	2*0.004
85	Vloer	ss	5.00	N	N	0.0	-1.5	4	1	Eind	-1.5	±40.0	2*0.004
86	Vloer	ss	5.00	N	N	0.0	-2.4	4	1	Eind	-2.4	±40.0	2*0.004
87	Vloer	ss	5.00	N	N	0.0	-2.4	4	1	Eind	-2.4	±40.0	2*0.004
88	Vloer	ss	5.00	N	N	0.0	-2.3	4	1	Eind	-2.3	±40.0	2*0.004
89	Vloer	ss	5.00	N	N	0.0	-2.1	4	1	Eind	-2.1	±40.0	2*0.004
90	Vloer	ss	5.00	N	N	0.0	-2.3	4	1	Eind	-2.3	±40.0	2*0.004
91	Vloer	ss	4.70	N	N	0.0	-3.3	4	1	Eind	-3.3	±37.6	2*0.004
92	Vloer	ss	4.70	N	N	0.0	-3.9	4	1	Eind	-3.9	±37.6	2*0.004
93	Vloer	ss	4.70	N	N	0.0	-3.7	4	1	Eind	-3.7	±37.6	2*0.004
94	Vloer	ss	4.70	N	N	0.0	-3.5	4	1	Eind	-3.5	±37.6	2*0.004
95	Vloer	ss	4.70	N	N	0.0	-3.5	4	1	Eind	-3.5	±37.6	2*0.004
125	Dak	ss	5.00	N	N	0.0	-2.0	3	1	Eind	-2.0	-40.0	2*0.004
127	Dak	ss	5.00	N	N	0.0	-1.8	3	1	Eind	-1.8	-40.0	2*0.004
129	Dak	ss	5.00	N	N	0.0	-2.7	3	1	Eind	-2.7	-40.0	2*0.004
131	Dak	ss	5.00	N	N	0.0	-1.5	4	1	Eind	-1.5	-40.0	2*0.004
133	Dak	ss	5.00	N	N	0.0	-2.3	4	1	Eind	-2.3	-40.0	2*0.004
135	Dak	ss	4.70	N	N	0.0	-3.5	4	1	Eind	-3.5	-37.6	2*0.004
147	Vloer	ss	5.00	N	N	0.0	-2.0	4	1	Eind	-2.0	±40.0	2*0.004
167	Vloer	ss	4.70	N	N	0.0	-3.5	4	1	Eind	-3.5	±37.6	2*0.004
168	Vloer	ss	5.00	N	N	0.0	-2.1	4	1	Eind	-2.1	±40.0	2*0.004
169	Vloer	ss	5.00	N	N	0.0	-1.7	3	1	Eind	-1.7	±40.0	2*0.004
170	Vloer	ss	5.00	N	N	0.0	4.1	3	1	Eind	4.1	±40.0	2*0.004
							-0.1	4	1	Eind	-0.1		
171	Vloer	ss	5.00	N	N	0.0	4.7	3	1	Eind	4.7	±40.0	2*0.004
							-0.2	4	1	Eind	-0.2		
172	Vloer	db	5.00	N	N	0.0	-0.6	3	1	Eind	-0.6	±20.0	0.004

Onderdeel.....:

TOETSING DOORBUIGING

Staaft	Soort	Mtg	Lengte [m]	Overst I	Overst J	Zeeg [mm]	u_{tot} [mm]	BC	Sit	u [mm]	Toelaatbaar [mm]	*1
--------	-------	-----	------------	----------	----------	-----------	----------------	----	-----	--------	------------------	----

173	Vloer	ss	5.00	N	N	0.0	-2.1	4	1	Eind	-2.1	±40.0	2*0.004
174	Vloer	ss	4.70	N	N	0.0	-3.4	4	1	Eind	-3.4	±37.6	2*0.004

TOETSING HORIZONTALE VERPLAATSING

Staaft	BC	Sit	Lengte [m]	u_{eind} [mm]	Toelaatbaar [mm]	Maatgevend [h/]
15	3	1	4.700	-4.9	15.7	300 scheefstand
16	3	1	5.000	-2.0	16.7	300 scheefstand
17	3	1	5.000	-0.3	16.7	300 scheefstand
18	4	1	5.000	-1.0	16.7	300 scheefstand
19	3	1	5.000	-1.0	16.7	300 scheefstand
20	3	1	5.000	-1.9	16.7	300 scheefstand
21	3	1	5.000	-1.1	16.7	300 scheefstand
22	3	1	4.700	-2.2	15.7	300 scheefstand
23	3	1	5.000	-1.9	16.7	300 scheefstand
24	3	1	5.000	-0.3	16.7	300 scheefstand
25	4	1	5.000	1.0	16.7	300 scheefstand
26	4	1	5.000	0.9	16.7	300 scheefstand
27	3	1	5.000	-1.7	16.7	300 scheefstand
28	3	1	5.000	-1.1	16.7	300 scheefstand
29	3	1	4.700	-4.4	15.7	300 scheefstand
31	3	1	4.700	-5.3	15.7	300 scheefstand
32	3	1	5.000	-2.0	16.7	300 scheefstand
34	3	1	5.000	-0.3	16.7	300 scheefstand
36	4	1	5.000	-0.8	16.7	300 scheefstand
38	3	1	5.000	-1.0	16.7	300 scheefstand
40	3	1	5.000	-1.9	16.7	300 scheefstand
42	3	1	5.000	-1.1	16.7	300 scheefstand
44	3	1	4.700	-2.6	15.7	300 scheefstand
51	3	1	4.700	-5.8	15.7	300 scheefstand
52	3	1	5.000	-1.9	16.7	300 scheefstand
53	3	1	5.000	-0.3	16.7	300 scheefstand
55	4	1	5.000	-0.5	16.7	300 scheefstand
57	3	1	5.000	-2.0	16.7	300 scheefstand
58	3	1	4.700	-6.3	15.7	300 scheefstand
59	3	1	5.000	-2.0	16.7	300 scheefstand
60	3	1	4.700	-6.8	15.7	300 scheefstand
61	3	1	5.000	-2.0	16.7	300 scheefstand
62	3	1	4.700	-6.7	15.7	300 scheefstand
63	3	1	4.700	-6.7	15.7	300 scheefstand
64	3	1	4.700	-6.7	15.7	300 scheefstand
65	3	1	5.000	-1.9	16.7	300 scheefstand
66	3	1	5.000	-1.9	16.7	300 scheefstand
67	3	1	4.700	-6.7	15.7	300 scheefstand
96	3	1	5.000	-0.9	16.7	300 scheefstand
97	3	1	5.000	-1.9	16.7	300 scheefstand
98	3	1	5.000	-1.1	16.7	300 scheefstand
99	3	1	5.000	-0.3	16.7	300 scheefstand
100	4	1	5.000	-0.3	16.7	300 scheefstand
101	3	1	5.000	-0.9	16.7	300 scheefstand
102	3	1	5.000	-1.9	16.7	300 scheefstand
103	3	1	5.000	-1.1	16.7	300 scheefstand
104	3	1	5.000	-0.3	16.7	300 scheefstand
105	4	1	5.000	0.0	16.7	300 scheefstand
106	3	1	5.000	-0.8	16.7	300 scheefstand
107	3	1	5.000	-1.9	16.7	300 scheefstand

Onderdeel.....:

TOETSING HORIZONTALE VERPLAATSING

Staaft	BC	Sit	Lengte [m]	u_{eind} [mm]	Toelaatbaar [mm]	Maatgevend [h/]
108	3	1	5.000	-1.1	16.7	300 scheefstand
109	3	1	5.000	-0.4	16.7	300 scheefstand
110	4	1	5.000	0.2	16.7	300 scheefstand
111	3	1	5.000	-0.8	16.7	300 scheefstand
112	3	1	5.000	-1.8	16.7	300 scheefstand
113	3	1	5.000	-1.1	16.7	300 scheefstand
114	3	1	5.000	-0.4	16.7	300 scheefstand
115	4	1	5.000	0.5	16.7	300 scheefstand
116	3	1	5.000	-0.7	16.7	300 scheefstand
117	3	1	5.000	-1.8	16.7	300 scheefstand
118	3	1	5.000	-1.1	16.7	300 scheefstand
119	3	1	5.000	-0.3	16.7	300 scheefstand
120	4	1	5.000	0.8	16.7	300 scheefstand
121	3	1	5.000	-0.7	16.7	300 scheefstand
122	3	1	5.000	-1.7	16.7	300 scheefstand

123	3	1	5.000	-1.1	16.7	300	scheefstand
124	3	1	4.700	-3.0	15.7	300	scheefstand
126	3	1	4.700	-3.7	15.7	300	scheefstand
128	3	1	4.700	-4.4	15.7	300	scheefstand
130	3	1	4.700	-4.4	15.7	300	scheefstand
132	3	1	4.700	-4.4	15.7	300	scheefstand
134	3	1	4.700	-4.4	15.7	300	scheefstand
177	3	1	7.071	0.0	23.6	300	scheefstand

TOETSING HOR. VERPLAATSING GLOBAAL

Er is een maximale horizontale verplaatsing van 0.0212 [m] gevonden bij knoop 23 en combinatie 3; belastingsituatie 1 (combinatietype 2). Bij een hoogte van 19.700 [m] levert dit $h / 931$ (toel.: $h / 300$).

A - 2 Facade A

Technosoft Raamwerken release 6.79a

17 jan 2024

Project.....: MM20152
 Dimensies....: kN;m;rad (tenzij anders aangegeven)
 Bestand.....: K:\Projecten\MM20152\10 Constructeur\03 DO - Definitief
 Ontwerp\reacties\facade as A.rww

Belastingbreedte.: 2.350
 Rekenmodel.....: 1e-orde-elastisch.
 Theorie voor de bepaling van de krachtsverdeling:
 Geometrisch lineair.
 Fysisch lineair.

Gunstige werking van de permanente belasting wordt automatisch verwerkt.

Toegepaste normen volgens Eurocode met Nederlandse NB

Belastingen	NEN-EN 1990:2002	C2:2010,A1:2019	NB:2019(nl)
	NEN-EN 1991-1-1:2002	C1/C11:2019	NB:2019(nl)
	NEN-EN 1991-1-4:2005	C2:2011	NB:2011(nl)
Staal	NEN-EN 1993-1-1:2006	C2:2011,A1:2016	NB:2016(nl)

GEOMETRIE

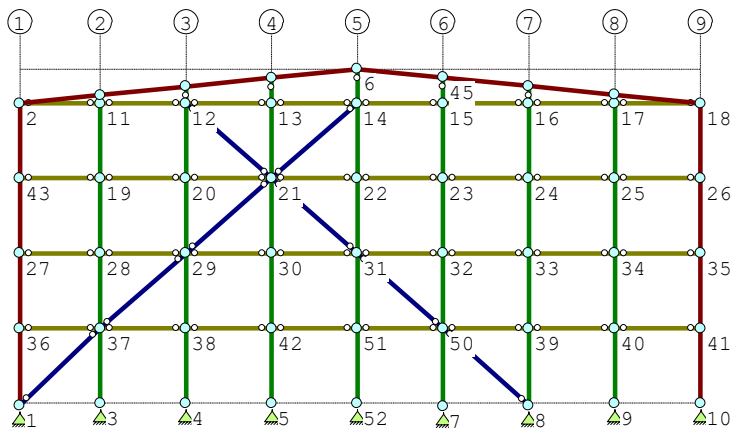

STRAMIENLIJNEN

Nr.	Naam	X	Z-min	Z-max
1	2	4.700	-0.175	19.500
2	3	9.700	-0.175	19.500
3	4	14.700	-0.175	19.500
4	5	19.700	-0.175	19.500
5	6	24.700	-0.175	19.500
6	7	29.700	-0.175	19.500
7	8	34.700	-0.175	19.500
8	9	39.700	-0.175	19.500
9	1	0.000	-0.175	19.500

NIVEAUS

Nr.	Z	X-min	X-max
1	0.000	0.000	39.700
2	4.375	0.000	39.700
3	8.750	0.000	39.700
4	13.125	0.000	39.700
5	17.500	0.000	39.700
6	19.500	0.000	39.700

Onderdeel.....:

MATERIALEN

Mt	Kwaliteit	E-modulus[N/mm2]	S.G.	Pois.	Uitz. coëff
1	S235	210000	78.5	0.30	1.2000e-05
2	S355	210000	78.5	0.30	1.2000e-05

PROFIELEN [mm]

Prof.	Omschrijving	Materiaal	Oppervlak	Traagheid	Vormf.
1	HEA160	1:S235	3.8800e+03	1.6730e+07	0.00
2	IPE500	2:S355	1.1550e+04	4.8200e+08	0.00
3	K150/100/4CF	1:S235	1.8948e+03	5.9460e+06	0.00
4	K150/150/5CF	1:S235	2.8356e+03	9.8212e+06	0.00

PROFIELEN vervolg [mm]

Prof.	Staaftype	Breedte	Hoogte	e	Type	b1	h1	b2	h2
1	0:Normaal	160	152	76.0					
2	0:Normaal	200	500	250.0					
3	0:Normaal	100	150	75.0					
4	0:Normaal	150	150	75.0					

PROFIELVORMEN [mm]

1 HEA160



2 IPE500



3 K150/100/4CF



4 K150/150/5CF



KNOPEN

Knoop	X	Z	Knoop	X	Z
1	0.000	-0.118	6	19.700	19.500
2	0.000	17.500	7	24.700	-0.175
3	4.700	0.000	8	29.700	-0.118
4	9.700	0.000	9	34.700	0.000
5	14.700	0.000	10	39.700	0.000
11	4.700	17.500	16	29.700	17.500
12	9.700	17.500	17	34.700	17.500
13	14.700	17.500	18	39.700	17.500
14	19.700	17.500	19	4.700	13.125
15	24.700	17.500	20	9.700	13.125
21	14.700	13.125	26	39.700	13.125
22	19.700	13.125	27	0.000	8.750
23	24.700	13.125	28	4.700	8.750
24	29.700	13.125	29	9.700	8.750
25	34.700	13.125	30	14.700	8.750
31	19.700	8.750	36	0.000	4.375
32	24.700	8.750	37	4.700	4.375
33	29.700	8.750	38	9.700	4.375
34	34.700	8.750	39	29.700	4.375
35	39.700	8.750	40	34.700	4.375
41	39.700	4.375	46	29.700	18.500
42	14.700	4.375	47	34.700	18.000
43	0.000	13.125	48	9.700	18.485

Onderdeel.....:

KNOPEN

Knoop	X	Z	Knoop	X	Z
44	14.700	18.992	49	4.700	17.977
45	24.700	19.000	50	24.700	4.375
51	19.700	4.375			
52	19.700	0.000			

STAVEN

St.	ki	kj	Profiel	Aansl.i	Aansl.j	Lengte	Opm.
1	1	36	1:HEA160	NDM	NDM	4.493	
2	6	14	2:IPE500	ND-	NDM	2.000	
3	2	11	3:K150/100/4CF	ND-	ND-	4.700	
4	11	19	2:IPE500	NDM	NDM	4.375	
5	11	12	3:K150/100/4CF	ND-	ND-	5.000	
6	12	20	2:IPE500	NDM	NDM	4.375	
7	12	13	3:K150/100/4CF	ND-	ND-	5.000	
8	13	21	2:IPE500	NDM	NDM	4.375	
9	13	14	3:K150/100/4CF	ND-	ND-	5.000	
10	14	22	2:IPE500	NDM	NDM	4.375	
11	14	15	3:K150/100/4CF	ND-	ND-	5.000	
12	15	23	2:IPE500	NDM	NDM	4.375	
13	15	16	3:K150/100/4CF	ND-	ND-	5.000	
14	16	24	2:IPE500	NDM	NDM	4.375	
15	16	17	3:K150/100/4CF	ND-	ND-	5.000	
16	17	25	2:IPE500	NDM	NDM	4.375	
17	17	18	3:K150/100/4CF	ND-	ND-	5.000	

18	18	26	1:HEA160	NDM	NDM	4.375
19	19	28	2:IPE500	NDM	NDM	4.375
20	19	20	3:K150/100/4CF	ND-	ND-	5.000
21	20	29	2:IPE500	NDM	NDM	4.375
22	20	21	3:K150/100/4CF	ND-	ND-	5.000
23	21	30	2:IPE500	NDM	NDM	4.375
24	21	22	3:K150/100/4CF	ND-	ND-	5.000
25	22	31	2:IPE500	NDM	NDM	4.375
26	22	23	3:K150/100/4CF	ND-	ND-	5.000
27	23	32	2:IPE500	NDM	NDM	4.375
28	23	24	3:K150/100/4CF	ND-	ND-	5.000
29	24	33	2:IPE500	NDM	NDM	4.375
30	24	25	3:K150/100/4CF	ND-	ND-	5.000
31	25	34	2:IPE500	NDM	NDM	4.375
32	25	26	3:K150/100/4CF	ND-	ND-	5.000
33	26	35	1:HEA160	NDM	NDM	4.375
34	27	28	3:K150/100/4CF	ND-	ND-	4.700
35	28	37	2:IPE500	NDM	NDM	4.375
36	28	29	3:K150/100/4CF	ND-	ND-	5.000
37	29	30	3:K150/100/4CF	ND-	ND-	5.000
38	30	31	3:K150/100/4CF	ND-	ND-	5.000
39	31	32	3:K150/100/4CF	ND-	ND-	5.000
40	32	33	3:K150/100/4CF	ND-	ND-	5.000
41	33	34	3:K150/100/4CF	ND-	ND-	5.000
42	34	40	2:IPE500	NDM	NDM	4.375
43	34	35	3:K150/100/4CF	ND-	ND-	5.000
44	35	41	1:HEA160	NDM	NDM	4.375
45	36	27	1:HEA160	NDM	NDM	4.375
46	36	37	3:K150/100/4CF	ND-	ND-	4.700
47	37	3	2:IPE500	NDM	NDM	4.375
48	37	38	3:K150/100/4CF	ND-	ND-	5.000
49	38	4	2:IPE500	NDM	NDM	4.375

Onderdeel.....:

STAVEN

St.	ki	kj	Profiel	Aansl.i	Aansl.j	Lengte	Opm.
50	39	8	2:IPE500	NDM	NDM	4.493	
51	39	40	3:K150/100/4CF	ND-	ND-	5.000	
52	40	9	2:IPE500	NDM	NDM	4.375	
53	40	41	3:K150/100/4CF	ND-	ND-	5.000	
54	41	10	1:HEA160	NDM	NDM	4.375	
55	38	42	3:K150/100/4CF	ND-	ND-	5.000	
56	42	5	2:IPE500	NDM	NDM	4.375	
57	2	49	1:HEA160	NDM	NDM	4.724	
58	6	45	1:HEA160	NDM	NDM	5.025	
59	27	43	1:HEA160	NDM	NDM	4.375	
60	43	19	3:K150/100/4CF	ND-	ND-	4.700	
61	43	2	1:HEA160	NDM	NDM	4.375	
62	44	13	2:IPE500	ND-	NDM	1.492	
63	44	6	1:HEA160	NDM	NDM	5.026	
64	45	15	2:IPE500	ND-	NDM	1.500	
65	45	46	1:HEA160	NDM	NDM	5.025	
66	46	16	2:IPE500	ND-	NDM	1.000	
67	46	47	1:HEA160	NDM	NDM	5.025	
68	47	17	2:IPE500	ND-	NDM	0.500	
69	47	18	1:HEA160	NDM	NDM	5.025	
70	48	12	2:IPE500	ND-	NDM	0.985	
71	48	44	1:HEA160	NDM	NDM	5.026	
72	49	11	2:IPE500	ND-	NDM	0.477	
73	49	48	1:HEA160	NDM	NDM	5.026	
74	50	39	3:K150/100/4CF	ND-	ND-	5.000	
75	50	7	2:IPE500	NDM	NDM	4.550	
76	33	39	2:IPE500	NDM	NDM	4.375	
77	29	38	2:IPE500	NDM	NDM	4.375	
78	31	51	2:IPE500	NDM	NDM	4.375	
79	51	52	2:IPE500	NDM	NDM	4.375	
80	32	50	2:IPE500	NDM	NDM	4.375	
81	30	42	2:IPE500	NDM	NDM	4.375	
82	42	51	3:K150/100/4CF	ND-	ND-	5.000	
83	51	50	3:K150/100/4CF	ND-	ND-	5.000	
84	1	37	4:K150/150/5CF	ND-	ND-	6.502	
85	37	29	4:K150/150/5CF	ND-	ND-	6.644	
86	29	21	4:K150/150/5CF	ND-	ND-	6.644	
87	21	14	4:K150/150/5CF	ND-	ND-	6.644	
88	12	21	4:K150/150/5CF	ND-	ND-	6.644	

89	21	31	4:K150/150/5CF	ND-	ND-	6.644
90	31	50	4:K150/150/5CF	ND-	ND-	6.644
91	50	8	4:K150/150/5CF	ND-	ND-	6.722

VASTE STEUNPUNTEN

Nr.	knoop	Kode	XZR 1=vast 0=vrij	Hoek
1	1	110		0.00
2	3	110		0.00
3	4	110		0.00
4	5	110		0.00
5	7	110		0.00
6	8	110		0.00
7	9	110		0.00
8	10	110		0.00
9	52	110		0.00

Onderdeel....:

BELASTINGGENERATIE ALGEMEEN.

Betrouwbaarheidsklasse.....:	2	Referentieperiode.....:	50
Gebouwdiepte.....:	39.00	Gebouwhoogte.....:	19.50
Niveau aansl.terrein.....:	0.00	E.g. scheid.w. [kN/m2]:	0.00

WIND

Terrein categorie ...[4.3.2]....:	Onbebouwd		
Windgebied	3	Vb,0 ..[4.2].....:	24.500
Positie spant in het gebouw....:	0.000	Kr ...[4.3.2].....:	0.209
z0	0.200	Zmin ..[4.3.2].....:	4.000
Co wind van links ..[4.3.3]....:	1.000	Co wind van rechts....:	1.000
Co wind loodrecht ..[4.3.3]....:	1.000		
Cpi wind van links ..[7.2.9]....:	0.200	-0.300	
Cpi windloodrecht ...[7.2.9]....:	0.200	-0.300	
Cpi wind van rechts ..[7.2.9]....:	0.200	-0.300	
Cfr windwrijving ...[7.5].....:	0.040		

STAFTYPEN

Type	staven
1:Vloer.	: 3-17-2,20-36-2,37-41,43,46,48,51,53,55,60,74 : 82,83
4:Wand / kolom.	: 2-16-2,19-31-2,35,42,47,49,50,52,56,62-72-2 : 75-81
5:Linker gevel.	: 1,45,59,61
6:Rechter gevel.	: 18,33,44,54
7:Dak.	: 57,58,63-73-2
9:Open.	: 84-91

LASTVELDEN

Wind staven Sneeuw staven

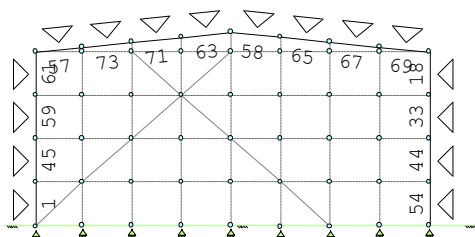

WIND DAKTYPES

Nr.	Staaft Type	reductie bij wind van links	reductie bij wind van rechts	Cpe volgens art:
1	1-61 Gevel	1.000	1.000	7.2.2
2	57-63 Zadeldak	1.000	1.000	7.2.5
3	58-69 Zadeldak	1.000	1.000	7.2.5
4	18-54 Gevel	1.000	1.000	7.2.2

WIND ZONES

Wind van links Wind van rechts

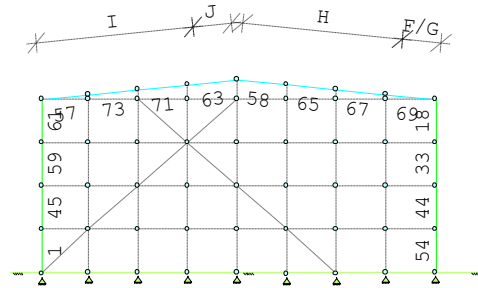
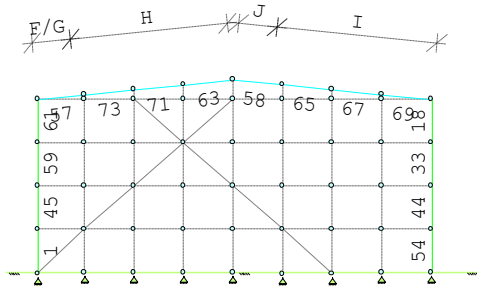

Onderdeel....:

WIND VAN LINKS ZONES

Nr.	Staaft	Positie	Lengte	Zone
1	1-61	0.000	17.618	D
2	57-63	0.000	3.900	F/G
3	57-63	3.900	15.901	H
4	58-69	0.000	3.900	J
5	58-69	3.900	16.200	I
6	18-54	0.000	17.500	E

WIND VAN RECHTS ZONES

Nr.	Staaft	Positie	Lengte	Zone
1	18-54	0.000	17.500	D
2	58-69	0.000	3.900	F/G
3	58-69	3.900	16.200	H
4	57-63	0.000	3.900	J
5	57-63	3.900	15.901	I
6	1-61	0.000	17.618	E

Wind indexen

Index	CsCd	Cpe/Cpi	qp	breedte	reductie	Qw	Zone	Hoek(en)
Qw1		0.300	0.869	2.350		-0.613	-i	
Qw2	1.00	0.800	0.869	2.350		-1.634	D	
Qw3	1.00	0.016	0.869	2.350		-0.033	F	5.8
Qw4	1.00	0.016	0.869	2.350		-0.033	H	5.8
Qw5	1.00	-0.628	0.869	2.350		1.283	J	5.7
Qw6	1.00	-0.586	0.869	2.350		1.197	I	5.7
Qw7	1.00	-0.500	0.869	2.350		1.021	E	
Qw8		-0.200	0.869	2.350		0.408	+i	
Qw9	1.00	-1.636	0.869	2.350		3.341	F	5.8
Qw10	1.00	-0.576	0.869	2.350		1.176	H	5.8
Qw11	1.00	0.014	0.869	2.350		-0.028	F	5.7
Qw12	1.00	0.014	0.869	2.350		-0.028	H	5.7
Qw13	1.00	-0.632	0.869	2.350		1.291	J	5.8
Qw14	1.00	-0.584	0.869	2.350		1.193	I	5.8
Qw15	1.00	-1.644	0.869	2.350		3.358	F	5.7
Qw16	1.00	-0.579	0.869	2.350		1.183	H	5.7
Qw17	1.00	0.186	0.869	2.350		-0.380	J	5.7
Qw18	1.00	0.184	0.869	2.350		-0.376	J	5.8

BELASTINGGEVALLEN

B.G.	Omschrijving	Type
	1 Permanente belasting	EGZ=-1.00
g*	2 Wind van links onderdruk A	7
g*	3 Wind van links overdruk A	8
g*	4 Wind van links onderdruk B	9
g*	5 Wind van links overdruk B	10
g*	6 Wind van links onderdruk C	37
g*	7 Wind van links overdruk C	38
g*	8 Wind van links onderdruk D	39
g*	9 Wind van links overdruk D	40
g*	10 Wind van rechts onderdruk A	11
g*	11 Wind van rechts overdruk A	12
g*	12 Wind van rechts onderdruk B	13
g*	13 Wind van rechts overdruk B	14
g*	14 Wind van rechts onderdruk C	41
g*	15 Wind van rechts overdruk C	42
g*	16 Wind van rechts onderdruk D	43
g*	17 Wind van rechts overdruk D	44
	18 SNEEUW	22 Sneeuw A
	19 Knik	0 Onbekend

g = gegeneerd belastinggeval

* = belastinggeval bevat 1 of meer handmatig toegevoegde en/of gewijzigde lasten

Onderdeel....:

BELASTINGEN

B.G:1 Permanente belasting

Eigen gewicht van alle staven is meegenomen in berekening. Richting:↓

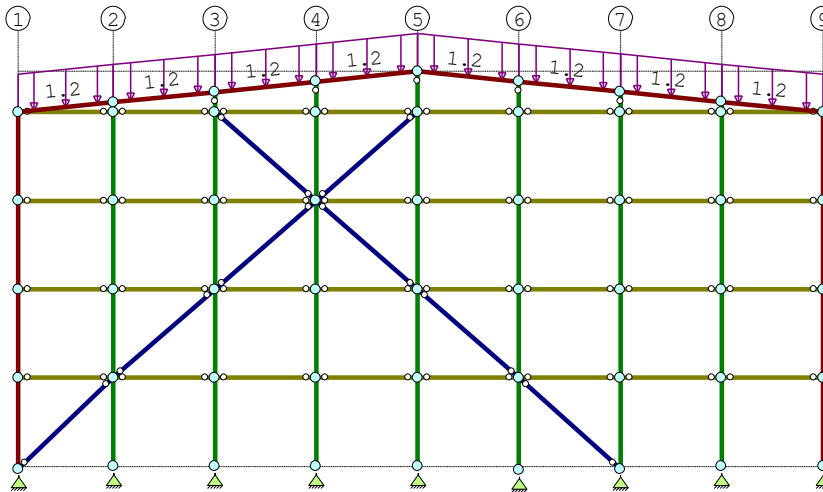

STAAFBELASTINGEN

B.G:1 Permanente belasting

Staat	Type	q1/p/m	q2	A	B	ψ ₀	ψ ₁	ψ ₂
57	5:QZGloobaal	-1.20	-1.20	0.000	0.000			
73	5:QZGloobaal	-1.20	-1.20	0.000	0.000			
71	5:QZGloobaal	-1.20	-1.20	0.000	0.000			
63	5:QZGloobaal	-1.20	-1.20	0.000	0.000			
58	5:QZGloobaal	-1.20	-1.20	0.000	0.000			
65	5:QZGloobaal	-1.20	-1.20	0.000	0.000			
67	5:QZGloobaal	-1.20	-1.20	0.000	0.000			
69	5:QZGloobaal	-1.20	-1.20	0.000	0.000			

REACTIES

B.G:1 Permanente belasting

Kn.	X	Z	M
1	1.99	12.55	
3	0.00	28.16	
4	0.00	28.69	
5	0.00	29.11	
7	0.01	29.24	
8	-2.01	29.85	
9	0.00	27.35	
10	0.01	10.23	
52	0.00	29.52	

0.00 224.71 : Som van de reacties
 0.00 -224.71 : Som van de belastingen

Onderdeel.....:

BELASTINGEN

B.G:2 Wind van links onderdruk A

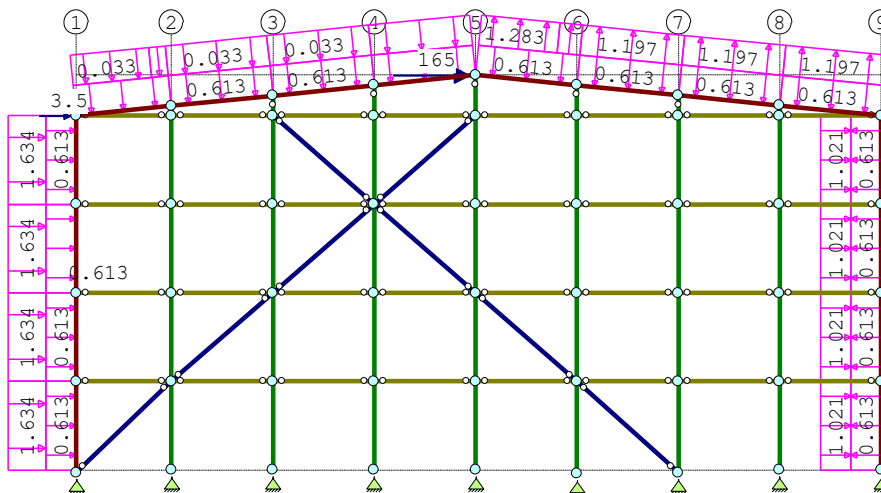

KNOOPBELASTINGEN

B.G:2 Wind van links onderdruk A

Last	Knoop	Richting	waarde	ψ ₀	ψ ₁	ψ ₂	Opm.
1	6	X	165.000	0.00	0.20	0.00	*
2	2	X	3.500	0.00	0.20	0.00	*

Opmerkingen

[*] Deze belasting is handmatig toegevoegd of gewijzigd.

STAAFBELASTINGEN

B.G:2 Wind van links onderdruk A

Staaftype	Index	q1/p/m	q2	A	B	Ψ ₀	Ψ ₁	Ψ ₂
1 1:QZLokaal	Qw1	-0.61	-0.61	0.118	0.000	0.00	0.20	0.00
45 1:QZLokaal	Qw1	-0.61	-0.61	0.000	0.000	0.00	0.20	0.00
59 1:QZLokaal	Qw1	-0.61	-0.61	0.000	0.000	0.00	0.20	0.00
61 1:QZLokaal	Qw1	-0.61	-0.61	0.000	0.000	0.00	0.20	0.00
57 1:QZLokaal	Qw1	-0.61	-0.61	0.000	0.000	0.00	0.20	0.00
73 1:QZLokaal	Qw1	-0.61	-0.61	0.000	0.000	0.00	0.20	0.00
71 1:QZLokaal	Qw1	-0.61	-0.61	0.000	0.000	0.00	0.20	0.00
63 1:QZLokaal	Qw1	-0.61	-0.61	0.000	0.000	0.00	0.20	0.00
58 1:QZLokaal	Qw1	-0.61	-0.61	0.000	0.000	0.00	0.20	0.00
65 1:QZLokaal	Qw1	-0.61	-0.61	0.000	0.000	0.00	0.20	0.00
67 1:QZLokaal	Qw1	-0.61	-0.61	0.000	0.000	0.00	0.20	0.00
69 1:QZLokaal	Qw1	-0.61	-0.61	0.000	0.000	0.00	0.20	0.00
18 1:QZLokaal	Qw1	-0.61	-0.61	0.000	0.000	0.00	0.20	0.00
33 1:QZLokaal	Qw1	-0.61	-0.61	0.000	0.000	0.00	0.20	0.00
44 1:QZLokaal	Qw1	-0.61	-0.61	0.000	0.000	0.00	0.20	0.00
54 1:QZLokaal	Qw1	-0.61	-0.61	0.000	0.000	0.00	0.20	0.00
1 1:QZLokaal	Qw2	-1.63	-1.63	0.118	0.000	0.00	0.20	0.00
45 1:QZLokaal	Qw2	-1.63	-1.63	0.000	0.000	0.00	0.20	0.00
59 1:QZLokaal	Qw2	-1.63	-1.63	0.000	0.000	0.00	0.20	0.00
61 1:QZLokaal	Qw2	-1.63	-1.63	0.000	0.000	0.00	0.20	0.00
57 1:QZLokaal	Qw3	-0.03	-0.03	0.000	0.824	0.00	0.20	0.00
57 1:QZLokaal	Qw4	-0.03	-0.03	3.900	0.000	0.00	0.20	0.00
73 1:QZLokaal	Qw4	-0.03	-0.03	0.000	0.000	0.00	0.20	0.00
71 1:QZLokaal	Qw4	-0.03	-0.03	0.000	0.000	0.00	0.20	0.00
63 1:QZLokaal	Qw4	-0.03	-0.03	0.000	0.000	0.00	0.20	0.00
58 1:QZLokaal	Qw5	1.28	1.28	0.000	1.125	0.00	0.20	0.00
58 1:QZLokaal	Qw6	1.20	1.20	3.900	0.000	0.00	0.20	0.00
65 1:QZLokaal	Qw6	1.20	1.20	0.000	0.000	0.00	0.20	0.00
67 1:QZLokaal	Qw6	1.20	1.20	0.000	0.000	0.00	0.20	0.00
69 1:QZLokaal	Qw6	1.20	1.20	0.000	0.000	0.00	0.20	0.00
18 1:QZLokaal	Qw7	1.02	1.02	0.000	0.000	0.00	0.20	0.00
33 1:QZLokaal	Qw7	1.02	1.02	0.000	0.000	0.00	0.20	0.00
44 1:QZLokaal	Qw7	1.02	1.02	0.000	0.000	0.00	0.20	0.00
54 1:QZLokaal	Qw7	1.02	1.02	0.000	0.000	0.00	0.20	0.00

Onderdeel.....:

REACTIES

B.G:2 Wind van links onderdruk A

Kn.	X	Z	M
1	-109.77	-101.75	
3	-0.75	12.21	
4	-0.84	-83.04	
5	-0.65	2.72	
7	-0.45	-1.92	
8	-102.95	90.19	
9	-0.58	-3.10	
10	-0.72	1.49	
52	-0.73	83.91	
			-217.46
		0.70	: Som van de reacties
			217.46
		-0.70	: Som van de belastingen

BELASTINGEN

B.G:3 Wind van links overdruk A

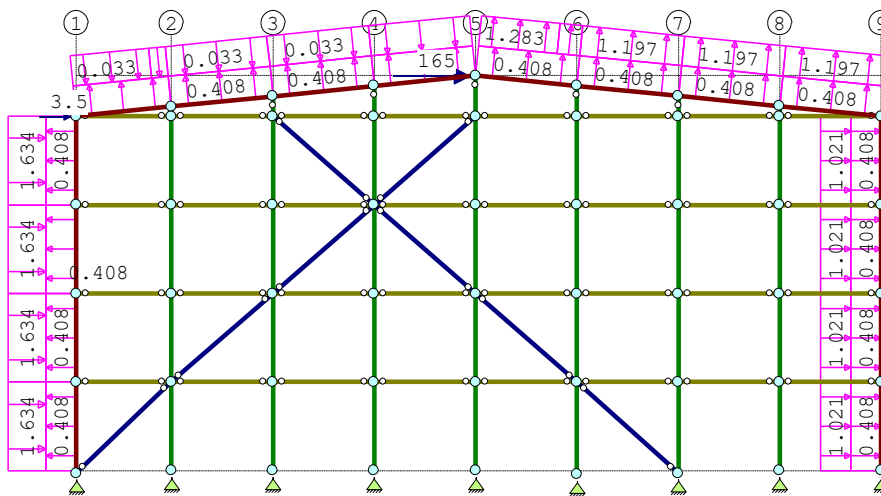

KNOOPBELASTINGEN

B.G:3 Wind van links overdruk A

Last	Knoop	Richting	waarde	Ψ ₀	Ψ ₁	Ψ ₂	Opm.
1	6	X	165.000	0.00	0.20	0.00	*
2	2	X	3.500	0.00	0.20	0.00	*

Opmerkingen

[*] Deze belasting is handmatig toegevoegd of gewijzigd.

STAAFBELASTINGEN

B.G:3 Wind van links overdruk A

Staaftype	Index	q1/p/m	q2	A	B	Ψ ₀	Ψ ₁	Ψ ₂
1 1:QZLokaal	Qw8	0.41	0.41	0.118	0.000	0.00	0.20	0.00
45 1:QZLokaal	Qw8	0.41	0.41	0.000	0.000	0.00	0.20	0.00
59 1:QZLokaal	Qw8	0.41	0.41	0.000	0.000	0.00	0.20	0.00
61 1:QZLokaal	Qw8	0.41	0.41	0.000	0.000	0.00	0.20	0.00
57 1:QZLokaal	Qw8	0.41	0.41	0.000	0.000	0.00	0.20	0.00
73 1:QZLokaal	Qw8	0.41	0.41	0.000	0.000	0.00	0.20	0.00
71 1:QZLokaal	Qw8	0.41	0.41	0.000	0.000	0.00	0.20	0.00
63 1:QZLokaal	Qw8	0.41	0.41	0.000	0.000	0.00	0.20	0.00
58 1:QZLokaal	Qw8	0.41	0.41	0.000	0.000	0.00	0.20	0.00
65 1:QZLokaal	Qw8	0.41	0.41	0.000	0.000	0.00	0.20	0.00
67 1:QZLokaal	Qw8	0.41	0.41	0.000	0.000	0.00	0.20	0.00
69 1:QZLokaal	Qw8	0.41	0.41	0.000	0.000	0.00	0.20	0.00
18 1:QZLokaal	Qw8	0.41	0.41	0.000	0.000	0.00	0.20	0.00
33 1:QZLokaal	Qw8	0.41	0.41	0.000	0.000	0.00	0.20	0.00
44 1:QZLokaal	Qw8	0.41	0.41	0.000	0.000	0.00	0.20	0.00
54 1:QZLokaal	Qw8	0.41	0.41	0.000	0.000	0.00	0.20	0.00
1 1:QZLokaal	Qw2	-1.63	-1.63	0.118	0.000	0.00	0.20	0.00
45 1:QZLokaal	Qw2	-1.63	-1.63	0.000	0.000	0.00	0.20	0.00
59 1:QZLokaal	Qw2	-1.63	-1.63	0.000	0.000	0.00	0.20	0.00

Onderdeel....:

STAAFBELASTINGEN

B.G:3 Wind van links overdruk A

Staaftype	Index	q1/p/m	q2	A	B	Ψ ₀	Ψ ₁	Ψ ₂
61 1:QZLokaal	Qw2	-1.63	-1.63	0.000	0.000	0.00	0.20	0.00
57 1:QZLokaal	Qw3	-0.03	-0.03	0.000	0.824	0.00	0.20	0.00
57 1:QZLokaal	Qw4	-0.03	-0.03	3.900	0.000	0.00	0.20	0.00
73 1:QZLokaal	Qw4	-0.03	-0.03	0.000	0.000	0.00	0.20	0.00
71 1:QZLokaal	Qw4	-0.03	-0.03	0.000	0.000	0.00	0.20	0.00
63 1:QZLokaal	Qw4	-0.03	-0.03	0.000	0.000	0.00	0.20	0.00
58 1:QZLokaal	Qw5	1.28	1.28	0.000	1.125	0.00	0.20	0.00
58 1:QZLokaal	Qw6	1.20	1.20	3.900	0.000	0.00	0.20	0.00
65 1:QZLokaal	Qw6	1.20	1.20	0.000	0.000	0.00	0.20	0.00
67 1:QZLokaal	Qw6	1.20	1.20	0.000	0.000	0.00	0.20	0.00
69 1:QZLokaal	Qw6	1.20	1.20	0.000	0.000	0.00	0.20	0.00
18 1:QZLokaal	Qw7	1.02	1.02	0.000	0.000	0.00	0.20	0.00
33 1:QZLokaal	Qw7	1.02	1.02	0.000	0.000	0.00	0.20	0.00
44 1:QZLokaal	Qw7	1.02	1.02	0.000	0.000	0.00	0.20	0.00
54 1:QZLokaal	Qw7	1.02	1.02	0.000	0.000	0.00	0.20	0.00

REACTIES

B.G:3 Wind van links overdruk A

Kn.	X	Z	M
1	-105.96	-102.28	
3	-0.73	4.47	
4	-0.81	-88.39	
5	-0.65	-0.83	
7	-0.44	-9.33	
8	-104.84	86.71	
9	-0.79	-8.26	
10	-2.50	-1.24	
52	-0.74	79.31	
-217.46		-39.84	: Som van de reacties
217.46		39.84	: Som van de belastingen

BELASTINGEN

B.G:4 Wind van links onderdruk B

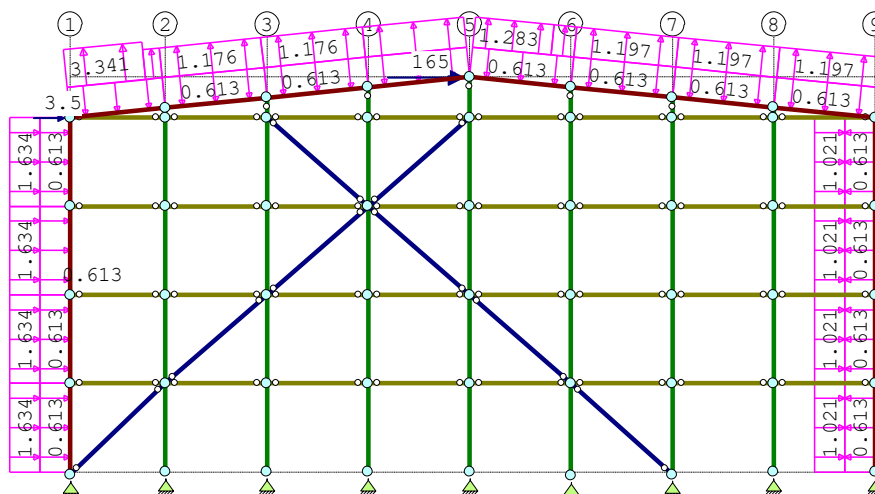

KNOOPBELASTINGEN

B.G:4 Wind van links onderdruk B

Last	Knoop	Richting	waarde	Ψ ₀	Ψ ₁	Ψ ₂	Opm.
1	6	X	165.000	0.00	0.20	0.00	*

2 2 X 3.500 0.00 0.20 0.00 *

Opmerkingen

[*] Deze belasting is handmatig toegevoegd of gewijzigd.

Onderdeel.....:

STAAFBELASTINGEN

B.G:4 Wind van links onderdruk B

Staaftype	Type	Index	q1/p/m	q2	A	B	Ψ_0	Ψ_1	Ψ_2
1	1:QZLokaal	Qw1	-0.61	-0.61	0.118	0.000	0.00	0.20	0.00
45	1:QZLokaal	Qw1	-0.61	-0.61	0.000	0.000	0.00	0.20	0.00
59	1:QZLokaal	Qw1	-0.61	-0.61	0.000	0.000	0.00	0.20	0.00
61	1:QZLokaal	Qw1	-0.61	-0.61	0.000	0.000	0.00	0.20	0.00
57	1:QZLokaal	Qw1	-0.61	-0.61	0.000	0.000	0.00	0.20	0.00
73	1:QZLokaal	Qw1	-0.61	-0.61	0.000	0.000	0.00	0.20	0.00
71	1:QZLokaal	Qw1	-0.61	-0.61	0.000	0.000	0.00	0.20	0.00
63	1:QZLokaal	Qw1	-0.61	-0.61	0.000	0.000	0.00	0.20	0.00
58	1:QZLokaal	Qw1	-0.61	-0.61	0.000	0.000	0.00	0.20	0.00
65	1:QZLokaal	Qw1	-0.61	-0.61	0.000	0.000	0.00	0.20	0.00
67	1:QZLokaal	Qw1	-0.61	-0.61	0.000	0.000	0.00	0.20	0.00
69	1:QZLokaal	Qw1	-0.61	-0.61	0.000	0.000	0.00	0.20	0.00
18	1:QZLokaal	Qw1	-0.61	-0.61	0.000	0.000	0.00	0.20	0.00
33	1:QZLokaal	Qw1	-0.61	-0.61	0.000	0.000	0.00	0.20	0.00
44	1:QZLokaal	Qw1	-0.61	-0.61	0.000	0.000	0.00	0.20	0.00
54	1:QZLokaal	Qw1	-0.61	-0.61	0.000	0.000	0.00	0.20	0.00
1	1:QZLokaal	Qw2	-1.63	-1.63	0.118	0.000	0.00	0.20	0.00
45	1:QZLokaal	Qw2	-1.63	-1.63	0.000	0.000	0.00	0.20	0.00
59	1:QZLokaal	Qw2	-1.63	-1.63	0.000	0.000	0.00	0.20	0.00
61	1:QZLokaal	Qw2	-1.63	-1.63	0.000	0.000	0.00	0.20	0.00
57	1:QZLokaal	Qw9	3.34	3.34	0.000	0.824	0.00	0.20	0.00
57	1:QZLokaal	Qw10	1.18	1.18	3.900	0.000	0.00	0.20	0.00
73	1:QZLokaal	Qw10	1.18	1.18	0.000	0.000	0.00	0.20	0.00
71	1:QZLokaal	Qw10	1.18	1.18	0.000	0.000	0.00	0.20	0.00
63	1:QZLokaal	Qw10	1.18	1.18	0.000	0.000	0.00	0.20	0.00
58	1:QZLokaal	Qw5	1.28	1.28	0.000	1.125	0.00	0.20	0.00
58	1:QZLokaal	Qw6	1.20	1.20	3.900	0.000	0.00	0.20	0.00
65	1:QZLokaal	Qw6	1.20	1.20	0.000	0.000	0.00	0.20	0.00
67	1:QZLokaal	Qw6	1.20	1.20	0.000	0.000	0.00	0.20	0.00
69	1:QZLokaal	Qw6	1.20	1.20	0.000	0.000	0.00	0.20	0.00
18	1:QZLokaal	Qw7	1.02	1.02	0.000	0.000	0.00	0.20	0.00
33	1:QZLokaal	Qw7	1.02	1.02	0.000	0.000	0.00	0.20	0.00
44	1:QZLokaal	Qw7	1.02	1.02	0.000	0.000	0.00	0.20	0.00
54	1:QZLokaal	Qw7	1.02	1.02	0.000	0.000	0.00	0.20	0.00

REACTIES

B.G:4 Wind van links onderdruk B

Kn.	X	Z	M
1	-108.62	-108.15	
3	-0.73	2.00	
4	-0.81	-86.34	
5	-0.63	-3.21	
7	-0.43	-1.70	
8	-100.98	88.32	
9	-0.57	-3.07	
10	-0.72	1.44	
52	-0.70	79.20	
-214.18		-31.52	: Som van de reacties
214.18		31.52	: Som van de belastingen

Onderdeel.....:

BELASTINGEN

B.G:5 Wind van links overdruk B

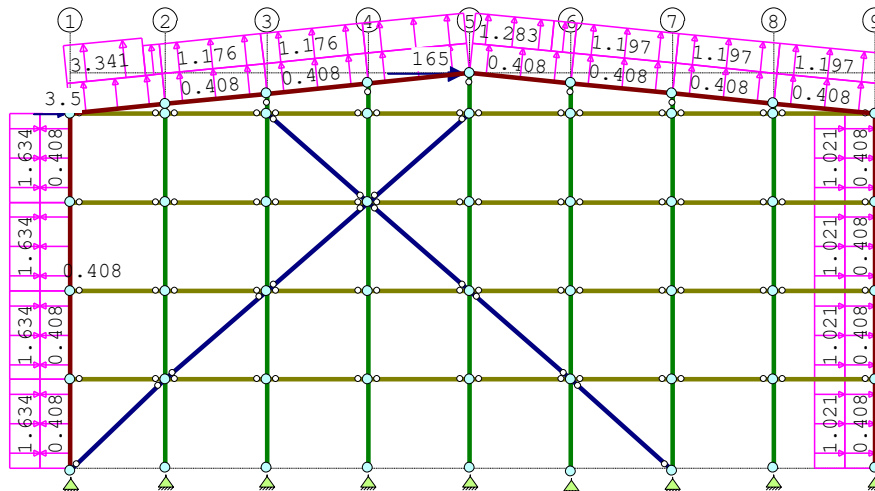

KNOOPBELASTINGEN

B.G:5 Wind van links overdruk B

Last Knoop	Richting	waarde	Ψ_0	Ψ_1	Ψ_2	Opm.
------------	----------	--------	----------	----------	----------	------

1	6 X	165.000	0.00	0.20	0.00	*
2	2 X	3.500	0.00	0.20	0.00	*

Opmerkingen

[*] Deze belasting is handmatig toegevoegd of gewijzigd.

STAAFBELASTINGEN

B.G:5 Wind van links overdruk B

Staaftype	Type	Index	q1/p/m	q2	A	B	Ψ_0	Ψ_1	Ψ_2
1	1:QZLokaal	Qw8	0.41	0.41	0.118	0.000	0.00	0.20	0.00
45	1:QZLokaal	Qw8	0.41	0.41	0.000	0.000	0.00	0.20	0.00
59	1:QZLokaal	Qw8	0.41	0.41	0.000	0.000	0.00	0.20	0.00
61	1:QZLokaal	Qw8	0.41	0.41	0.000	0.000	0.00	0.20	0.00
57	1:QZLokaal	Qw8	0.41	0.41	0.000	0.000	0.00	0.20	0.00
73	1:QZLokaal	Qw8	0.41	0.41	0.000	0.000	0.00	0.20	0.00
71	1:QZLokaal	Qw8	0.41	0.41	0.000	0.000	0.00	0.20	0.00
63	1:QZLokaal	Qw8	0.41	0.41	0.000	0.000	0.00	0.20	0.00
58	1:QZLokaal	Qw8	0.41	0.41	0.000	0.000	0.00	0.20	0.00
65	1:QZLokaal	Qw8	0.41	0.41	0.000	0.000	0.00	0.20	0.00
67	1:QZLokaal	Qw8	0.41	0.41	0.000	0.000	0.00	0.20	0.00
69	1:QZLokaal	Qw8	0.41	0.41	0.000	0.000	0.00	0.20	0.00
18	1:QZLokaal	Qw8	0.41	0.41	0.000	0.000	0.00	0.20	0.00
33	1:QZLokaal	Qw8	0.41	0.41	0.000	0.000	0.00	0.20	0.00
44	1:QZLokaal	Qw8	0.41	0.41	0.000	0.000	0.00	0.20	0.00
54	1:QZLokaal	Qw8	0.41	0.41	0.000	0.000	0.00	0.20	0.00
1	1:QZLokaal	Qw2	-1.63	-1.63	0.118	0.000	0.00	0.20	0.00
45	1:QZLokaal	Qw2	-1.63	-1.63	0.000	0.000	0.00	0.20	0.00
59	1:QZLokaal	Qw2	-1.63	-1.63	0.000	0.000	0.00	0.20	0.00
61	1:QZLokaal	Qw2	-1.63	-1.63	0.000	0.000	0.00	0.20	0.00
57	1:QZLokaal	Qw9	3.34	3.34	0.000	0.824	0.00	0.20	0.00
57	1:QZLokaal	Qw10	1.18	1.18	3.900	0.000	0.00	0.20	0.00
73	1:QZLokaal	Qw10	1.18	1.18	0.000	0.000	0.00	0.20	0.00
71	1:QZLokaal	Qw10	1.18	1.18	0.000	0.000	0.00	0.20	0.00
63	1:QZLokaal	Qw10	1.18	1.18	0.000	0.000	0.00	0.20	0.00
58	1:QZLokaal	Qw5	1.28	1.28	0.000	1.125	0.00	0.20	0.00
58	1:QZLokaal	Qw6	1.20	1.20	3.900	0.000	0.00	0.20	0.00
65	1:QZLokaal	Qw6	1.20	1.20	0.000	0.000	0.00	0.20	0.00
67	1:QZLokaal	Qw6	1.20	1.20	0.000	0.000	0.00	0.20	0.00
69	1:QZLokaal	Qw6	1.20	1.20	0.000	0.000	0.00	0.20	0.00
18	1:QZLokaal	Qw7	1.02	1.02	0.000	0.000	0.00	0.20	0.00
33	1:QZLokaal	Qw7	1.02	1.02	0.000	0.000	0.00	0.20	0.00
44	1:QZLokaal	Qw7	1.02	1.02	0.000	0.000	0.00	0.20	0.00
54	1:QZLokaal	Qw7	1.02	1.02	0.000	0.000	0.00	0.20	0.00

Onderdeel.....

REACTIES

B.G:5 Wind van links overdruk B

Kn.	X	Z	M
1	-104.81	-108.68	
3	-0.71	-5.74	
4	-0.77	-91.69	
5	-0.62	-6.77	
7	-0.42	-9.11	
8	-102.87	84.84	
9	-0.77	-8.24	
10	-2.50	-1.29	
52	-0.72	74.61	
-214.18			-72.06 : Som van de reacties
214.18			72.06 : Som van de belastingen

BELASTINGEN

B.G:6 Wind van links onderdruk C

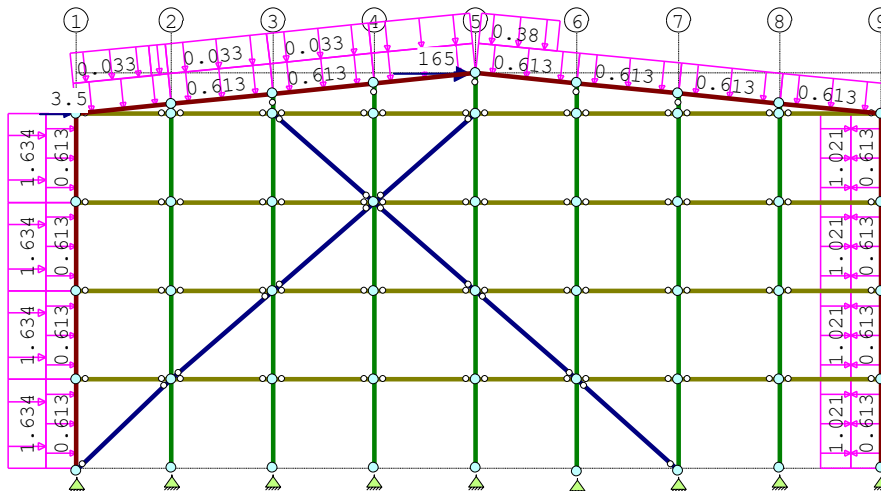

KNOOPBELASTINGEN

B.G:6 Wind van links onderdruk C

Last Knoop	Richting	waarde	Ψ_0	Ψ_1	Ψ_2	Opm.
------------	----------	--------	----------	----------	----------	------

1	6 X	165.000	0.00	0.20	0.00	*
2	2 X	3.500	0.00	0.20	0.00	*

Opmerkingen

[*] Deze belasting is handmatig toegevoegd of gewijzigd.

STAAFBELASTINGEN

B.G:6 Wind van links onderdruk C

Staaftype	Type	Index	q1/p/m	q2	A	B	ψ ₀	ψ ₁	ψ ₂
1	1:QZLokaal	Qw1	-0.61	-0.61	0.118	0.000	0.00	0.20	0.00
45	1:QZLokaal	Qw1	-0.61	-0.61	0.000	0.000	0.00	0.20	0.00
59	1:QZLokaal	Qw1	-0.61	-0.61	0.000	0.000	0.00	0.20	0.00
61	1:QZLokaal	Qw1	-0.61	-0.61	0.000	0.000	0.00	0.20	0.00
57	1:QZLokaal	Qw1	-0.61	-0.61	0.000	0.000	0.00	0.20	0.00
73	1:QZLokaal	Qw1	-0.61	-0.61	0.000	0.000	0.00	0.20	0.00
71	1:QZLokaal	Qw1	-0.61	-0.61	0.000	0.000	0.00	0.20	0.00
63	1:QZLokaal	Qw1	-0.61	-0.61	0.000	0.000	0.00	0.20	0.00
58	1:QZLokaal	Qw1	-0.61	-0.61	0.000	0.000	0.00	0.20	0.00
65	1:QZLokaal	Qw1	-0.61	-0.61	0.000	0.000	0.00	0.20	0.00
67	1:QZLokaal	Qw1	-0.61	-0.61	0.000	0.000	0.00	0.20	0.00
69	1:QZLokaal	Qw1	-0.61	-0.61	0.000	0.000	0.00	0.20	0.00
18	1:QZLokaal	Qw1	-0.61	-0.61	0.000	0.000	0.00	0.20	0.00
33	1:QZLokaal	Qw1	-0.61	-0.61	0.000	0.000	0.00	0.20	0.00
44	1:QZLokaal	Qw1	-0.61	-0.61	0.000	0.000	0.00	0.20	0.00
54	1:QZLokaal	Qw1	-0.61	-0.61	0.000	0.000	0.00	0.20	0.00
1	1:QZLokaal	Qw2	-1.63	-1.63	0.118	0.000	0.00	0.20	0.00
45	1:QZLokaal	Qw2	-1.63	-1.63	0.000	0.000	0.00	0.20	0.00
59	1:QZLokaal	Qw2	-1.63	-1.63	0.000	0.000	0.00	0.20	0.00

Onderdeel.....:

STAAFBELASTINGEN

B.G:6 Wind van links onderdruk C

Staaftype	Type	Index	q1/p/m	q2	A	B	ψ ₀	ψ ₁	ψ ₂
61	1:QZLokaal	Qw2	-1.63	-1.63	0.000	0.000	0.00	0.20	0.00
57	1:QZLokaal	Qw3	-0.03	-0.03	0.000	0.824	0.00	0.20	0.00
57	1:QZLokaal	Qw4	-0.03	-0.03	3.900	0.000	0.00	0.20	0.00
73	1:QZLokaal	Qw4	-0.03	-0.03	0.000	0.000	0.00	0.20	0.00
71	1:QZLokaal	Qw4	-0.03	-0.03	0.000	0.000	0.00	0.20	0.00
63	1:QZLokaal	Qw4	-0.03	-0.03	0.000	0.000	0.00	0.20	0.00
58	1:QZLokaal	Qw17	-0.38	-0.38	0.000	1.125	0.00	0.20	0.00
18	1:QZLokaal	Qw7	1.02	1.02	0.000	0.000	0.00	0.20	0.00
33	1:QZLokaal	Qw7	1.02	1.02	0.000	0.000	0.00	0.20	0.00
44	1:QZLokaal	Qw7	1.02	1.02	0.000	0.000	0.00	0.20	0.00
54	1:QZLokaal	Qw7	1.02	1.02	0.000	0.000	0.00	0.20	0.00

REACTIES

B.G:6 Wind van links onderdruk C

Kn.	X	Z	M
1	-108.39	-100.39	
3	-0.74	12.07	
4	-0.82	-81.89	
5	-0.64	3.04	
7	-0.43	5.15	
8	-101.87	94.89	
9	-0.57	3.39	
10	-0.72	4.14	
52	-0.71	86.04	
			-214.88
			26.44
			: Som van de reacties
			214.88
			-26.44
			: Som van de belastingen

BELASTINGEN

B.G:7 Wind van links overdruk C

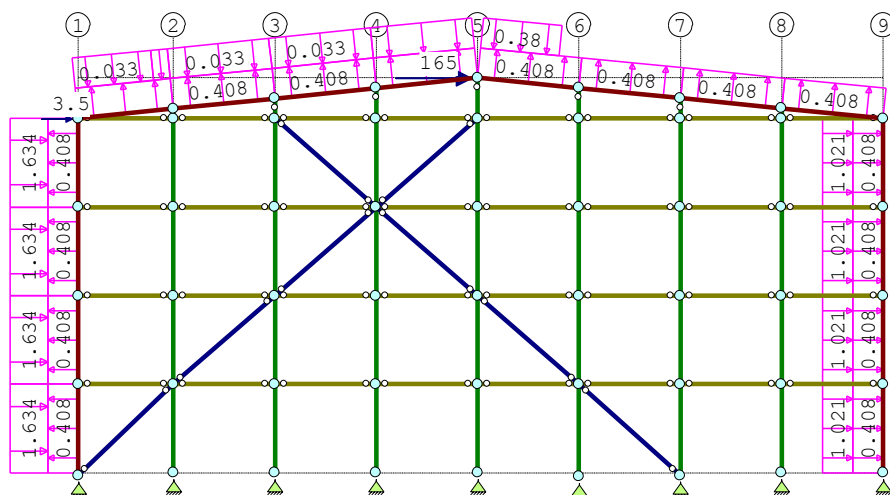

KNOOPBELASTINGEN

B.G:7 Wind van links overdruk C

Last	Knoop	Richting	waarde	ψ ₀	ψ ₁	ψ ₂	Opm.
------	-------	----------	--------	----------------	----------------	----------------	------

1	6 X	165.000	0.00	0.20	0.00	*
2	2 X	3.500	0.00	0.20	0.00	*

Opmerkingen

[*] Deze belasting is handmatig toegevoegd of gewijzigd.
Onderdeel.....:

STAAFBELASTINGEN

B.G:7 Wind van links overdruk C

Staat	Type	Index	q1/p/m	q2	A	B	Ψ ₀	Ψ ₁	Ψ ₂
1	1:QZLokaal	Qw8	0.41	0.41	0.118	0.000	0.00	0.20	0.00
45	1:QZLokaal	Qw8	0.41	0.41	0.000	0.000	0.00	0.20	0.00
59	1:QZLokaal	Qw8	0.41	0.41	0.000	0.000	0.00	0.20	0.00
61	1:QZLokaal	Qw8	0.41	0.41	0.000	0.000	0.00	0.20	0.00
57	1:QZLokaal	Qw8	0.41	0.41	0.000	0.000	0.00	0.20	0.00
73	1:QZLokaal	Qw8	0.41	0.41	0.000	0.000	0.00	0.20	0.00
71	1:QZLokaal	Qw8	0.41	0.41	0.000	0.000	0.00	0.20	0.00
63	1:QZLokaal	Qw8	0.41	0.41	0.000	0.000	0.00	0.20	0.00
58	1:QZLokaal	Qw8	0.41	0.41	0.000	0.000	0.00	0.20	0.00
65	1:QZLokaal	Qw8	0.41	0.41	0.000	0.000	0.00	0.20	0.00
67	1:QZLokaal	Qw8	0.41	0.41	0.000	0.000	0.00	0.20	0.00
69	1:QZLokaal	Qw8	0.41	0.41	0.000	0.000	0.00	0.20	0.00
18	1:QZLokaal	Qw8	0.41	0.41	0.000	0.000	0.00	0.20	0.00
33	1:QZLokaal	Qw8	0.41	0.41	0.000	0.000	0.00	0.20	0.00
44	1:QZLokaal	Qw8	0.41	0.41	0.000	0.000	0.00	0.20	0.00
54	1:QZLokaal	Qw8	0.41	0.41	0.000	0.000	0.00	0.20	0.00
1	1:QZLokaal	Qw2	-1.63	-1.63	0.118	0.000	0.00	0.20	0.00
45	1:QZLokaal	Qw2	-1.63	-1.63	0.000	0.000	0.00	0.20	0.00
59	1:QZLokaal	Qw2	-1.63	-1.63	0.000	0.000	0.00	0.20	0.00
61	1:QZLokaal	Qw2	-1.63	-1.63	0.000	0.000	0.00	0.20	0.00
57	1:QZLokaal	Qw3	-0.03	-0.03	0.000	0.824	0.00	0.20	0.00
73	1:QZLokaal	Qw4	-0.03	-0.03	3.900	0.000	0.00	0.20	0.00
71	1:QZLokaal	Qw4	-0.03	-0.03	0.000	0.000	0.00	0.20	0.00
63	1:QZLokaal	Qw4	-0.03	-0.03	0.000	0.000	0.00	0.20	0.00
58	1:QZLokaal	Qw17	-0.38	-0.38	0.000	1.125	0.00	0.20	0.00
18	1:QZLokaal	Qw7	1.02	1.02	0.000	0.000	0.00	0.20	0.00
33	1:QZLokaal	Qw7	1.02	1.02	0.000	0.000	0.00	0.20	0.00
44	1:QZLokaal	Qw7	1.02	1.02	0.000	0.000	0.00	0.20	0.00
54	1:QZLokaal	Qw7	1.02	1.02	0.000	0.000	0.00	0.20	0.00

REACTIES

B.G:7 Wind van links overdruk C

Kn.	X	Z	M
1	-104.57	-100.91	
3	-0.72	4.34	
4	-0.79	-87.24	
5	-0.63	-0.52	
7	-0.42	-2.26	
8	-103.75	91.41	
9	-0.77	-1.77	
10	-2.49	1.41	
52	-0.73	81.44	

-214.88 -14.10 : Som van de reacties

214.88 14.10 : Som van de belastingen

Onderdeel.....:

BELASTINGEN

B.G:8 Wind van links onderdruk D

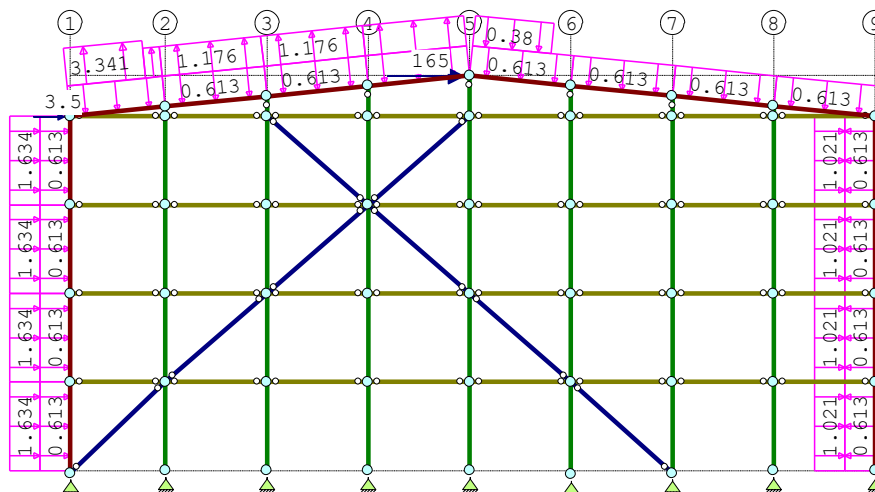

KNOOPBELASTINGEN

B.G:8 Wind van links onderdruk D

Last	Knoop	Richting	waarde	Ψ ₀	Ψ ₁	Ψ ₂	Opm.
1	6	X	165.000	0.00	0.20	0.00	*
2	2	X	3.500	0.00	0.20	0.00	*

Opmerkingen

[*] Deze belasting is handmatig toegevoegd of gewijzigd.

STAAFBELASTINGEN

B.G:8 Wind van links onderdruk D

Staf	Type	Index	q1/p/m	q2	A	B	Ψ_0	Ψ_1	Ψ_2
1	1:QZLokaal	Qw1	-0.61	-0.61	0.118	0.000	0.00	0.20	0.00
45	1:QZLokaal	Qw1	-0.61	-0.61	0.000	0.000	0.00	0.20	0.00
59	1:QZLokaal	Qw1	-0.61	-0.61	0.000	0.000	0.00	0.20	0.00
61	1:QZLokaal	Qw1	-0.61	-0.61	0.000	0.000	0.00	0.20	0.00
57	1:QZLokaal	Qw1	-0.61	-0.61	0.000	0.000	0.00	0.20	0.00
73	1:QZLokaal	Qw1	-0.61	-0.61	0.000	0.000	0.00	0.20	0.00
71	1:QZLokaal	Qw1	-0.61	-0.61	0.000	0.000	0.00	0.20	0.00
63	1:QZLokaal	Qw1	-0.61	-0.61	0.000	0.000	0.00	0.20	0.00
58	1:QZLokaal	Qw1	-0.61	-0.61	0.000	0.000	0.00	0.20	0.00
65	1:QZLokaal	Qw1	-0.61	-0.61	0.000	0.000	0.00	0.20	0.00
67	1:QZLokaal	Qw1	-0.61	-0.61	0.000	0.000	0.00	0.20	0.00
69	1:QZLokaal	Qw1	-0.61	-0.61	0.000	0.000	0.00	0.20	0.00
18	1:QZLokaal	Qw1	-0.61	-0.61	0.000	0.000	0.00	0.20	0.00
33	1:QZLokaal	Qw1	-0.61	-0.61	0.000	0.000	0.00	0.20	0.00
44	1:QZLokaal	Qw1	-0.61	-0.61	0.000	0.000	0.00	0.20	0.00
54	1:QZLokaal	Qw1	-0.61	-0.61	0.000	0.000	0.00	0.20	0.00
1	1:QZLokaal	Qw2	-1.63	-1.63	0.118	0.000	0.00	0.20	0.00
45	1:QZLokaal	Qw2	-1.63	-1.63	0.000	0.000	0.00	0.20	0.00
59	1:QZLokaal	Qw2	-1.63	-1.63	0.000	0.000	0.00	0.20	0.00
61	1:QZLokaal	Qw2	-1.63	-1.63	0.000	0.000	0.00	0.20	0.00
57	1:QZLokaal	Qw9	3.34	3.34	0.000	0.824	0.00	0.20	0.00
57	1:QZLokaal	Qw10	1.18	1.18	3.900	0.000	0.00	0.20	0.00
73	1:QZLokaal	Qw10	1.18	1.18	0.000	0.000	0.00	0.20	0.00
71	1:QZLokaal	Qw10	1.18	1.18	0.000	0.000	0.00	0.20	0.00
63	1:QZLokaal	Qw10	1.18	1.18	0.000	0.000	0.00	0.20	0.00
58	1:QZLokaal	Qw17	-0.38	-0.38	0.000	1.125	0.00	0.20	0.00
18	1:QZLokaal	Qw7	1.02	1.02	0.000	0.000	0.00	0.20	0.00
33	1:QZLokaal	Qw7	1.02	1.02	0.000	0.000	0.00	0.20	0.00
44	1:QZLokaal	Qw7	1.02	1.02	0.000	0.000	0.00	0.20	0.00
54	1:QZLokaal	Qw7	1.02	1.02	0.000	0.000	0.00	0.20	0.00

Onderdeel.....:

REACTIES

B.G:8 Wind van links onderdruk D

Kn.	X	Z	M
1	-107.24	-106.78	
3	-0.71	1.86	
4	-0.79	-85.19	
5	-0.61	-2.90	
7	-0.41	5.37	
8	-99.90	93.02	
9	-0.55	3.42	
10	-0.72	4.09	
52	-0.69	81.33	
-211.61		-5.78	: Som van de reacties
211.61		5.78	: Som van de belastingen

BELASTINGEN

B.G:9 Wind van links overdruk D

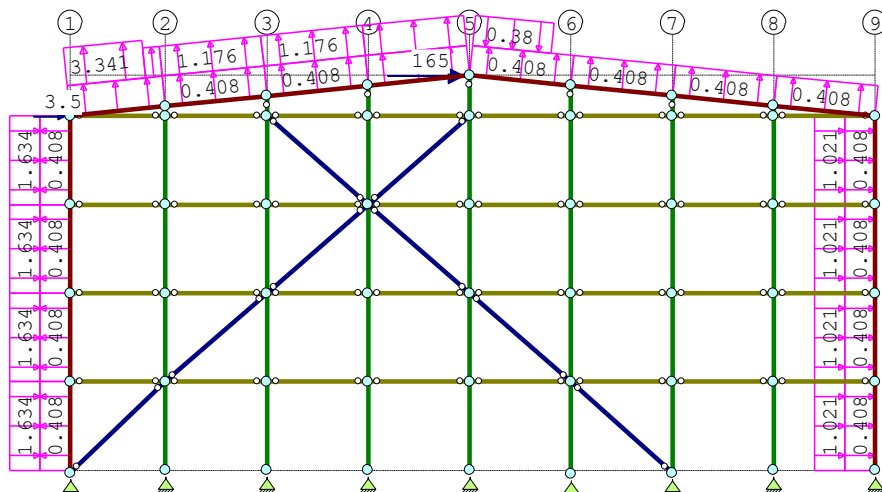

KNOOPBELASTINGEN

B.G:9 Wind van links overdruk D

Last	Knoop	Richting	waarde	Ψ_0	Ψ_1	Ψ_2	Opm.
1	6	X	165.000	0.00	0.20	0.00	*
2	2	X	3.500	0.00	0.20	0.00	*

Opmerkingen

[*] Deze belasting is handmatig toegevoegd of gewijzigd.

STAAFBELASTINGEN

B.G:9 Wind van links overdruk D

Staaft Type	Index	q1/p/m	q2	A	B	Ψ_0	Ψ_1	Ψ_2
1 1:QZLokaal	Qw8	0.41	0.41	0.118	0.000	0.00	0.20	0.00
45 1:QZLokaal	Qw8	0.41	0.41	0.000	0.000	0.00	0.20	0.00
59 1:QZLokaal	Qw8	0.41	0.41	0.000	0.000	0.00	0.20	0.00
61 1:QZLokaal	Qw8	0.41	0.41	0.000	0.000	0.00	0.20	0.00
57 1:QZLokaal	Qw8	0.41	0.41	0.000	0.000	0.00	0.20	0.00
73 1:QZLokaal	Qw8	0.41	0.41	0.000	0.000	0.00	0.20	0.00
71 1:QZLokaal	Qw8	0.41	0.41	0.000	0.000	0.00	0.20	0.00
63 1:QZLokaal	Qw8	0.41	0.41	0.000	0.000	0.00	0.20	0.00
58 1:QZLokaal	Qw8	0.41	0.41	0.000	0.000	0.00	0.20	0.00
65 1:QZLokaal	Qw8	0.41	0.41	0.000	0.000	0.00	0.20	0.00
67 1:QZLokaal	Qw8	0.41	0.41	0.000	0.000	0.00	0.20	0.00
69 1:QZLokaal	Qw8	0.41	0.41	0.000	0.000	0.00	0.20	0.00
18 1:QZLokaal	Qw8	0.41	0.41	0.000	0.000	0.00	0.20	0.00
33 1:QZLokaal	Qw8	0.41	0.41	0.000	0.000	0.00	0.20	0.00
44 1:QZLokaal	Qw8	0.41	0.41	0.000	0.000	0.00	0.20	0.00
54 1:QZLokaal	Qw8	0.41	0.41	0.000	0.000	0.00	0.20	0.00
1 1:QZLokaal	Qw2	-1.63	-1.63	0.118	0.000	0.00	0.20	0.00
45 1:QZLokaal	Qw2	-1.63	-1.63	0.000	0.000	0.00	0.20	0.00
59 1:QZLokaal	Qw2	-1.63	-1.63	0.000	0.000	0.00	0.20	0.00

Onderdeel.....:

STAAFBELASTINGEN				B.G:9 Wind van links overdruk D				
Staaft Type	Index	q1/p/m	q2	A	B	Ψ_0	Ψ_1	Ψ_2
61 1:QZLokaal	Qw2	-1.63	-1.63	0.000	0.000	0.00	0.20	0.00
57 1:QZLokaal	Qw9	3.34	3.34	0.000	0.824	0.00	0.20	0.00
57 1:QZLokaal	Qw10	1.18	1.18	3.900	0.000	0.00	0.20	0.00
73 1:QZLokaal	Qw10	1.18	1.18	0.000	0.000	0.00	0.20	0.00
71 1:QZLokaal	Qw10	1.18	1.18	0.000	0.000	0.00	0.20	0.00
63 1:QZLokaal	Qw10	1.18	1.18	0.000	0.000	0.00	0.20	0.00
58 1:QZLokaal	Qw17	-0.38	-0.38	0.000	1.125	0.00	0.20	0.00
18 1:QZLokaal	Qw7	1.02	1.02	0.000	0.000	0.00	0.20	0.00
33 1:QZLokaal	Qw7	1.02	1.02	0.000	0.000	0.00	0.20	0.00
44 1:QZLokaal	Qw7	1.02	1.02	0.000	0.000	0.00	0.20	0.00
54 1:QZLokaal	Qw7	1.02	1.02	0.000	0.000	0.00	0.20	0.00

REACTIES				B.G:9 Wind van links overdruk D				
Kn.	X	Z	M					
1	-103.42	-107.31						
3	-0.70	-5.87						
4	-0.76	-90.54						
5	-0.60	-6.45						
7	-0.40	-2.03						
8	-101.78	89.54						
9	-0.75	-1.74						
10	-2.49	1.36						
52	-0.70	76.73						
		-211.61	-46.32	: Som van de reacties				
		211.61	46.32	: Som van de belastingen				

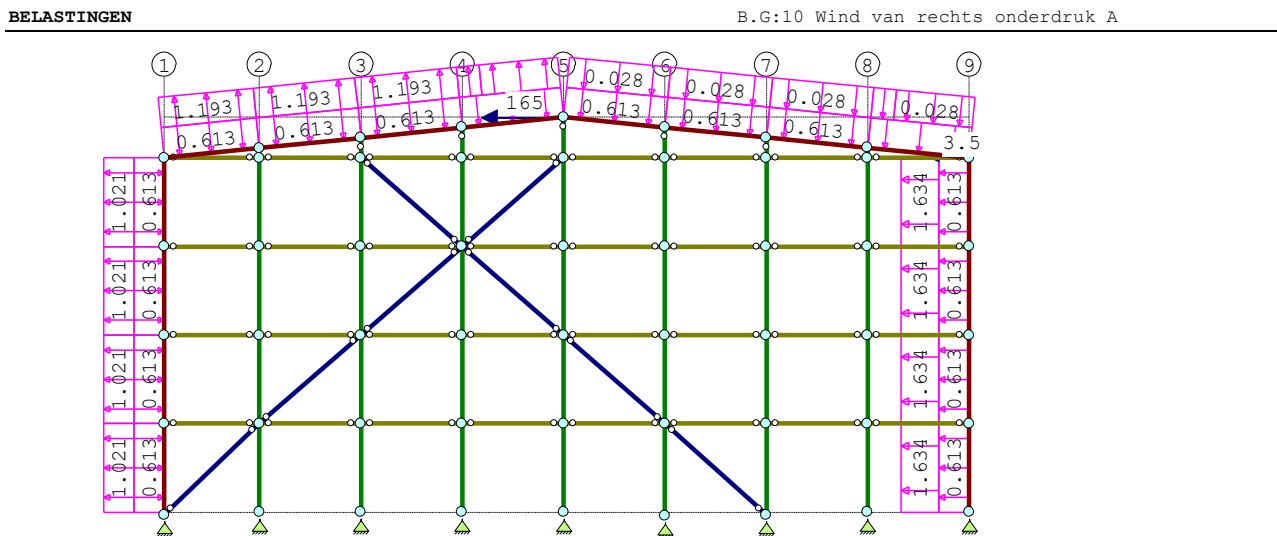

KNOOPBELASTINGEN				B.G:10 Wind van rechts onderdruk A				
Last	Knoop	Richting	waarde	Ψ_0	Ψ_1	Ψ_2	Opm.	
1	6	X	-165.000	0.00	0.20	0.00	*	
2	18	X	-3.500	0.00	0.20	0.00	*	

Opmerkingen

[*] Deze belasting is handmatig toegevoegd of gewijzigd.

Onderdeel.....:

STAAFBELASTINGEN

B.G:10 Wind van rechts onderdruk A

Staaftype	Index	q1/p/m	q2	A	B	Ψ ₀	Ψ ₁	Ψ ₂
1 1:QZLokaal	Qw1	-0.61	-0.61	0.118	0.000	0.00	0.20	0.00
45 1:QZLokaal	Qw1	-0.61	-0.61	0.000	0.000	0.00	0.20	0.00
59 1:QZLokaal	Qw1	-0.61	-0.61	0.000	0.000	0.00	0.20	0.00
61 1:QZLokaal	Qw1	-0.61	-0.61	0.000	0.000	0.00	0.20	0.00
57 1:QZLokaal	Qw1	-0.61	-0.61	0.000	0.000	0.00	0.20	0.00
73 1:QZLokaal	Qw1	-0.61	-0.61	0.000	0.000	0.00	0.20	0.00
71 1:QZLokaal	Qw1	-0.61	-0.61	0.000	0.000	0.00	0.20	0.00
63 1:QZLokaal	Qw1	-0.61	-0.61	0.000	0.000	0.00	0.20	0.00
58 1:QZLokaal	Qw1	-0.61	-0.61	0.000	0.000	0.00	0.20	0.00
65 1:QZLokaal	Qw1	-0.61	-0.61	0.000	0.000	0.00	0.20	0.00
67 1:QZLokaal	Qw1	-0.61	-0.61	0.000	0.000	0.00	0.20	0.00
69 1:QZLokaal	Qw1	-0.61	-0.61	0.000	0.000	0.00	0.20	0.00
18 1:QZLokaal	Qw1	-0.61	-0.61	0.000	0.000	0.00	0.20	0.00
33 1:QZLokaal	Qw1	-0.61	-0.61	0.000	0.000	0.00	0.20	0.00
44 1:QZLokaal	Qw1	-0.61	-0.61	0.000	0.000	0.00	0.20	0.00
54 1:QZLokaal	Qw1	-0.61	-0.61	0.000	0.000	0.00	0.20	0.00
54 1:QZLokaal	Qw2	-1.63	-1.63	0.000	0.000	0.00	0.20	0.00
44 1:QZLokaal	Qw2	-1.63	-1.63	0.000	0.000	0.00	0.20	0.00
33 1:QZLokaal	Qw2	-1.63	-1.63	0.000	0.000	0.00	0.20	0.00
18 1:QZLokaal	Qw2	-1.63	-1.63	0.000	0.000	0.00	0.20	0.00
69 1:QZLokaal	Qw11	-0.03	-0.03	1.125	0.000	0.00	0.20	0.00
69 1:QZLokaal	Qw12	-0.03	-0.03	0.000	3.900	0.00	0.20	0.00
67 1:QZLokaal	Qw12	-0.03	-0.03	0.000	0.000	0.00	0.20	0.00
65 1:QZLokaal	Qw12	-0.03	-0.03	0.000	0.000	0.00	0.20	0.00
58 1:QZLokaal	Qw12	-0.03	-0.03	0.000	0.000	0.00	0.20	0.00
63 1:QZLokaal	Qw13	1.29	1.29	1.126	0.000	0.00	0.20	0.00
63 1:QZLokaal	Qw14	1.19	1.19	0.000	3.900	0.00	0.20	0.00
71 1:QZLokaal	Qw14	1.19	1.19	0.000	0.000	0.00	0.20	0.00
73 1:QZLokaal	Qw14	1.19	1.19	0.000	0.000	0.00	0.20	0.00
57 1:QZLokaal	Qw14	1.19	1.19	0.000	0.000	0.00	0.20	0.00
61 1:QZLokaal	Qw7	1.02	1.02	0.000	0.000	0.00	0.20	0.00
59 1:QZLokaal	Qw7	1.02	1.02	0.000	0.000	0.00	0.20	0.00
45 1:QZLokaal	Qw7	1.02	1.02	0.000	0.000	0.00	0.20	0.00
1 1:QZLokaal	Qw7	1.02	1.02	0.118	0.000	0.00	0.20	0.00

REACTIES

B.G:10 Wind van rechts onderdruk A

Kn.	X	Z	M
1	102.20	98.54	
3	0.71	-7.42	
4	0.78	84.13	
5	0.64	-4.97	
7	0.42	6.12	
8	107.06	-93.37	
9	0.96	2.86	
10	3.91	-0.39	
52	0.75	-84.48	

217.44 1.02 : Som van de reacties

-217.44 -1.02 : Som van de belastingen

Onderdeel.....:

BELASTINGEN

B.G:11 Wind van rechts overdruk A

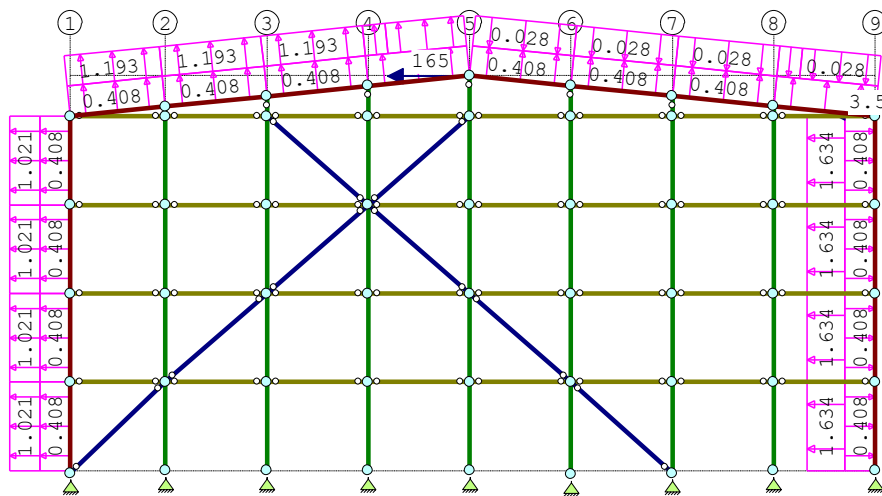

KNOOPBELASTINGEN

B.G:11 Wind van rechts overdruk A

Last	Knoop	Richting	waarde	Ψ ₀	Ψ ₁	Ψ ₂	Opm.
1	6	X	-165.000	0.00	0.20	0.00	*
2	18	X	-3.500	0.00	0.20	0.00	*

Opmerkingen

[*] Deze belasting is handmatig toegevoegd of gewijzigd.

STAAFBELASTINGEN

B.G:11 Wind van rechts overdruk A

Staaftype	Index	q1/p/m	q2	A	B	Ψ ₀	Ψ ₁	Ψ ₂
1 1:QZLokaal	Qw8	0.41	0.41	0.118	0.000	0.00	0.20	0.00
45 1:QZLokaal	Qw8	0.41	0.41	0.000	0.000	0.00	0.20	0.00
59 1:QZLokaal	Qw8	0.41	0.41	0.000	0.000	0.00	0.20	0.00
61 1:QZLokaal	Qw8	0.41	0.41	0.000	0.000	0.00	0.20	0.00
57 1:QZLokaal	Qw8	0.41	0.41	0.000	0.000	0.00	0.20	0.00
73 1:QZLokaal	Qw8	0.41	0.41	0.000	0.000	0.00	0.20	0.00
71 1:QZLokaal	Qw8	0.41	0.41	0.000	0.000	0.00	0.20	0.00
63 1:QZLokaal	Qw8	0.41	0.41	0.000	0.000	0.00	0.20	0.00
58 1:QZLokaal	Qw8	0.41	0.41	0.000	0.000	0.00	0.20	0.00
65 1:QZLokaal	Qw8	0.41	0.41	0.000	0.000	0.00	0.20	0.00
67 1:QZLokaal	Qw8	0.41	0.41	0.000	0.000	0.00	0.20	0.00
69 1:QZLokaal	Qw8	0.41	0.41	0.000	0.000	0.00	0.20	0.00
18 1:QZLokaal	Qw8	0.41	0.41	0.000	0.000	0.00	0.20	0.00
33 1:QZLokaal	Qw8	0.41	0.41	0.000	0.000	0.00	0.20	0.00
44 1:QZLokaal	Qw8	0.41	0.41	0.000	0.000	0.00	0.20	0.00
54 1:QZLokaal	Qw8	0.41	0.41	0.000	0.000	0.00	0.20	0.00
54 1:QZLokaal	Qw2	-1.63	-1.63	0.000	0.000	0.00	0.20	0.00
44 1:QZLokaal	Qw2	-1.63	-1.63	0.000	0.000	0.00	0.20	0.00
33 1:QZLokaal	Qw2	-1.63	-1.63	0.000	0.000	0.00	0.20	0.00
18 1:QZLokaal	Qw2	-1.63	-1.63	0.000	0.000	0.00	0.20	0.00
69 1:QZLokaal	Qw11	-0.03	-0.03	1.125	0.000	0.00	0.20	0.00
69 1:QZLokaal	Qw12	-0.03	-0.03	0.000	3.900	0.00	0.20	0.00
67 1:QZLokaal	Qw12	-0.03	-0.03	0.000	0.000	0.00	0.20	0.00
65 1:QZLokaal	Qw12	-0.03	-0.03	0.000	0.000	0.00	0.20	0.00
58 1:QZLokaal	Qw12	-0.03	-0.03	0.000	0.000	0.00	0.20	0.00
63 1:QZLokaal	Qw13	1.29	1.29	1.126	0.000	0.00	0.20	0.00
63 1:QZLokaal	Qw14	1.19	1.19	0.000	3.900	0.00	0.20	0.00
71 1:QZLokaal	Qw14	1.19	1.19	0.000	0.000	0.00	0.20	0.00
73 1:QZLokaal	Qw14	1.19	1.19	0.000	0.000	0.00	0.20	0.00
57 1:QZLokaal	Qw14	1.19	1.19	0.000	0.000	0.00	0.20	0.00
61 1:QZLokaal	Qw7	1.02	1.02	0.000	0.000	0.00	0.20	0.00
59 1:QZLokaal	Qw7	1.02	1.02	0.000	0.000	0.00	0.20	0.00
45 1:QZLokaal	Qw7	1.02	1.02	0.000	0.000	0.00	0.20	0.00
1 1:QZLokaal	Qw7	1.02	1.02	0.118	0.000	0.00	0.20	0.00

Onderdeel.....:

REACTIES

B.G:11 Wind van rechts overdruk A

Kn.	X	Z	M
1	106.02	98.01	
3	0.73	-15.15	
4	0.81	78.78	
5	0.65	-8.52	
7	0.44	-1.28	
8	105.17	-96.85	
9	0.75	-2.31	
10	2.13	-3.12	
52	0.74	-89.07	
217.44			-39.52 : Som van de reacties
-217.44			39.52 : Som van de belastingen

BELASTINGEN

B.G:12 Wind van rechts onderdruk B

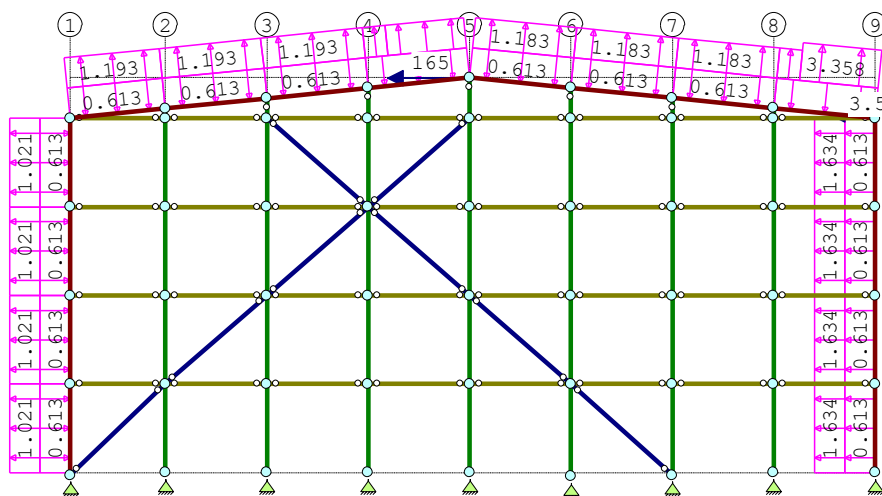

KNOOPBELASTINGEN

B.G:12 Wind van rechts onderdruk B

Last	Knoop	Richting	waarde	Ψ ₀	Ψ ₁	Ψ ₂	Opm.
1	6	X	-165.000	0.00	0.20	0.00	*
2	18	X	-3.500	0.00	0.20	0.00	*

Opmerkingen

[*] Deze belasting is handmatig toegevoegd of gewijzigd.

STAAFBELASTINGEN

B.G:12 Wind van rechts onderdruk B

StAAF	Type	Index	q1/p/m	q2	A	B	Ψ ₀	Ψ ₁	Ψ ₂
1	1:QZLokaal	Qw1	-0.61	-0.61	0.118	0.000	0.00	0.20	0.00
45	1:QZLokaal	Qw1	-0.61	-0.61	0.000	0.000	0.00	0.20	0.00
59	1:QZLokaal	Qw1	-0.61	-0.61	0.000	0.000	0.00	0.20	0.00
61	1:QZLokaal	Qw1	-0.61	-0.61	0.000	0.000	0.00	0.20	0.00
57	1:QZLokaal	Qw1	-0.61	-0.61	0.000	0.000	0.00	0.20	0.00
73	1:QZLokaal	Qw1	-0.61	-0.61	0.000	0.000	0.00	0.20	0.00
71	1:QZLokaal	Qw1	-0.61	-0.61	0.000	0.000	0.00	0.20	0.00
63	1:QZLokaal	Qw1	-0.61	-0.61	0.000	0.000	0.00	0.20	0.00
58	1:QZLokaal	Qw1	-0.61	-0.61	0.000	0.000	0.00	0.20	0.00
65	1:QZLokaal	Qw1	-0.61	-0.61	0.000	0.000	0.00	0.20	0.00
67	1:QZLokaal	Qw1	-0.61	-0.61	0.000	0.000	0.00	0.20	0.00
69	1:QZLokaal	Qw1	-0.61	-0.61	0.000	0.000	0.00	0.20	0.00
18	1:QZLokaal	Qw1	-0.61	-0.61	0.000	0.000	0.00	0.20	0.00
33	1:QZLokaal	Qw1	-0.61	-0.61	0.000	0.000	0.00	0.20	0.00
44	1:QZLokaal	Qw1	-0.61	-0.61	0.000	0.000	0.00	0.20	0.00
54	1:QZLokaal	Qw1	-0.61	-0.61	0.000	0.000	0.00	0.20	0.00
54	1:QZLokaal	Qw2	-1.63	-1.63	0.000	0.000	0.00	0.20	0.00
44	1:QZLokaal	Qw2	-1.63	-1.63	0.000	0.000	0.00	0.20	0.00
33	1:QZLokaal	Qw2	-1.63	-1.63	0.000	0.000	0.00	0.20	0.00

Onderdeel....:

STAAFBELASTINGEN

B.G:12 Wind van rechts onderdruk B

StAAF	Type	Index	q1/p/m	q2	A	B	Ψ ₀	Ψ ₁	Ψ ₂
18	1:QZLokaal	Qw2	-1.63	-1.63	0.000	0.000	0.00	0.20	0.00
69	1:QZLokaal	Qw15	3.36	3.36	1.125	0.000	0.00	0.20	0.00
69	1:QZLokaal	Qw16	1.18	1.18	0.000	3.900	0.00	0.20	0.00
67	1:QZLokaal	Qw16	1.18	1.18	0.000	0.000	0.00	0.20	0.00
65	1:QZLokaal	Qw16	1.18	1.18	0.000	0.000	0.00	0.20	0.00
58	1:QZLokaal	Qw16	1.18	1.18	0.000	0.000	0.00	0.20	0.00
63	1:QZLokaal	Qw13	1.29	1.29	1.126	0.000	0.00	0.20	0.00
63	1:QZLokaal	Qw14	1.19	1.19	0.000	3.900	0.00	0.20	0.00
71	1:QZLokaal	Qw14	1.19	1.19	0.000	0.000	0.00	0.20	0.00
73	1:QZLokaal	Qw14	1.19	1.19	0.000	0.000	0.00	0.20	0.00
57	1:QZLokaal	Qw14	1.19	1.19	0.000	0.000	0.00	0.20	0.00
61	1:QZLokaal	Qw7	1.02	1.02	0.000	0.000	0.00	0.20	0.00
59	1:QZLokaal	Qw7	1.02	1.02	0.000	0.000	0.00	0.20	0.00
45	1:QZLokaal	Qw7	1.02	1.02	0.000	0.000	0.00	0.20	0.00
1	1:QZLokaal	Qw7	1.02	1.02	0.118	0.000	0.00	0.20	0.00

REACTIES

B.G:12 Wind van rechts onderdruk B

Kn.	X	Z	M
1	100.50	96.86	
3	0.70	-7.33	
4	0.76	82.31	
5	0.62	-5.25	
7	0.40	-0.36	
8	105.63	-97.26	
9	0.94	-7.51	
10	3.89	-8.34	
52	0.73	-84.77	
214.18			-31.64 : Som van de reacties
-214.18			31.64 : Som van de belastingen

BELASTINGEN

B.G:13 Wind van rechts overdruk B

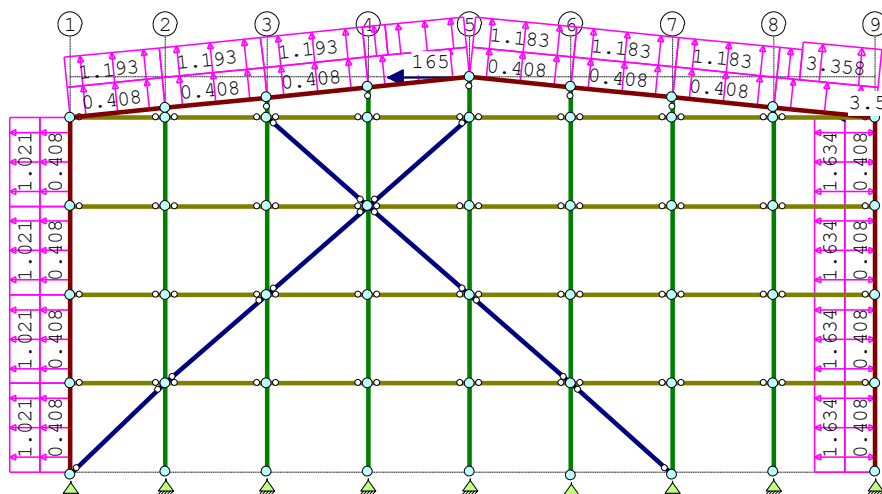

KNOOPBELASTINGEN

B.G:13 Wind van rechts overdruk B

Last	Knoop	Richting	waarde	Ψ ₀	Ψ ₁	Ψ ₂	Opm.
1	6	X	-165.000	0.00	0.20	0.00	*

2 18 X -3.500 0.00 0.20 0.00 *

Opmerkingen

[*] Deze belasting is handmatig toegevoegd of gewijzigd.

Onderdeel.....:

STAAFBELASTINGEN

B.G:13 Wind van rechts overdruk B

Staaftype	Type	Index	q1/p/m	q2	A	B	Ψ_0	Ψ_1	Ψ_2
1	1:QZLokaal	Qw8	0.41	0.41	0.118	0.000	0.00	0.20	0.00
45	1:QZLokaal	Qw8	0.41	0.41	0.000	0.000	0.00	0.20	0.00
59	1:QZLokaal	Qw8	0.41	0.41	0.000	0.000	0.00	0.20	0.00
61	1:QZLokaal	Qw8	0.41	0.41	0.000	0.000	0.00	0.20	0.00
57	1:QZLokaal	Qw8	0.41	0.41	0.000	0.000	0.00	0.20	0.00
73	1:QZLokaal	Qw8	0.41	0.41	0.000	0.000	0.00	0.20	0.00
71	1:QZLokaal	Qw8	0.41	0.41	0.000	0.000	0.00	0.20	0.00
63	1:QZLokaal	Qw8	0.41	0.41	0.000	0.000	0.00	0.20	0.00
58	1:QZLokaal	Qw8	0.41	0.41	0.000	0.000	0.00	0.20	0.00
65	1:QZLokaal	Qw8	0.41	0.41	0.000	0.000	0.00	0.20	0.00
67	1:QZLokaal	Qw8	0.41	0.41	0.000	0.000	0.00	0.20	0.00
69	1:QZLokaal	Qw8	0.41	0.41	0.000	0.000	0.00	0.20	0.00
18	1:QZLokaal	Qw8	0.41	0.41	0.000	0.000	0.00	0.20	0.00
33	1:QZLokaal	Qw8	0.41	0.41	0.000	0.000	0.00	0.20	0.00
44	1:QZLokaal	Qw8	0.41	0.41	0.000	0.000	0.00	0.20	0.00
54	1:QZLokaal	Qw8	0.41	0.41	0.000	0.000	0.00	0.20	0.00
54	1:QZLokaal	Qw2	-1.63	-1.63	0.000	0.000	0.00	0.20	0.00
44	1:QZLokaal	Qw2	-1.63	-1.63	0.000	0.000	0.00	0.20	0.00
33	1:QZLokaal	Qw2	-1.63	-1.63	0.000	0.000	0.00	0.20	0.00
18	1:QZLokaal	Qw2	-1.63	-1.63	0.000	0.000	0.00	0.20	0.00
69	1:QZLokaal	Qw15	3.36	3.36	1.125	0.000	0.00	0.20	0.00
69	1:QZLokaal	Qw16	1.18	1.18	0.000	3.900	0.00	0.20	0.00
67	1:QZLokaal	Qw16	1.18	1.18	0.000	0.000	0.00	0.20	0.00
65	1:QZLokaal	Qw16	1.18	1.18	0.000	0.000	0.00	0.20	0.00
58	1:QZLokaal	Qw16	1.18	1.18	0.000	0.000	0.00	0.20	0.00
63	1:QZLokaal	Qw13	1.29	1.29	1.126	0.000	0.00	0.20	0.00
63	1:QZLokaal	Qw14	1.19	1.19	0.000	3.900	0.00	0.20	0.00
71	1:QZLokaal	Qw14	1.19	1.19	0.000	0.000	0.00	0.20	0.00
73	1:QZLokaal	Qw14	1.19	1.19	0.000	0.000	0.00	0.20	0.00
57	1:QZLokaal	Qw14	1.19	1.19	0.000	0.000	0.00	0.20	0.00
61	1:QZLokaal	Qw7	1.02	1.02	0.000	0.000	0.00	0.20	0.00
59	1:QZLokaal	Qw7	1.02	1.02	0.000	0.000	0.00	0.20	0.00
45	1:QZLokaal	Qw7	1.02	1.02	0.000	0.000	0.00	0.20	0.00
1	1:QZLokaal	Qw7	1.02	1.02	0.118	0.000	0.00	0.20	0.00

REACTIES

B.G:13 Wind van rechts overdruk B

Kn.	X	Z	M
1	104.32	96.33	
3	0.71	-15.06	
4	0.79	76.97	
5	0.63	-8.80	
7	0.41	-7.77	
8	103.74	-100.74	
9	0.74	-12.68	
10	2.12	-11.07	
52	0.72	-89.36	
214.18		-72.18	: Som van de reacties
-214.18		72.18	: Som van de belastingen

Onderdeel.....:

BELASTINGEN

B.G:14 Wind van rechts onderdruk C

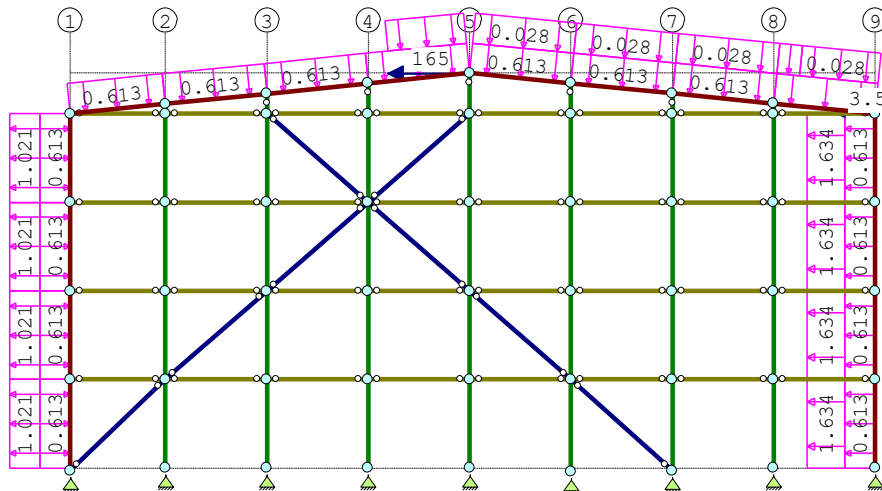

KNOOPBELASTINGEN

B.G:14 Wind van rechts onderdruk C

Last Knoop	Richting	waarde	Ψ_0	Ψ_1	Ψ_2	Opm.
------------	----------	--------	----------	----------	----------	------

1	6 X	-165.000	0.00	0.20	0.00	*
2	18 X	-3.500	0.00	0.20	0.00	*

Opmerkingen

[*] Deze belasting is handmatig toegevoegd of gewijzigd.

STAAFBELASTINGEN

B.G:14 Wind van rechts onderdruk C

Staaftype	Type	Index	q1/p/m	q2	A	B	ψ ₀	ψ ₁	ψ ₂
1	1:QZLokaal	Qw1	-0.61	-0.61	0.118	0.000	0.00	0.20	0.00
45	1:QZLokaal	Qw1	-0.61	-0.61	0.000	0.000	0.00	0.20	0.00
59	1:QZLokaal	Qw1	-0.61	-0.61	0.000	0.000	0.00	0.20	0.00
61	1:QZLokaal	Qw1	-0.61	-0.61	0.000	0.000	0.00	0.20	0.00
57	1:QZLokaal	Qw1	-0.61	-0.61	0.000	0.000	0.00	0.20	0.00
73	1:QZLokaal	Qw1	-0.61	-0.61	0.000	0.000	0.00	0.20	0.00
71	1:QZLokaal	Qw1	-0.61	-0.61	0.000	0.000	0.00	0.20	0.00
63	1:QZLokaal	Qw1	-0.61	-0.61	0.000	0.000	0.00	0.20	0.00
58	1:QZLokaal	Qw1	-0.61	-0.61	0.000	0.000	0.00	0.20	0.00
65	1:QZLokaal	Qw1	-0.61	-0.61	0.000	0.000	0.00	0.20	0.00
67	1:QZLokaal	Qw1	-0.61	-0.61	0.000	0.000	0.00	0.20	0.00
69	1:QZLokaal	Qw1	-0.61	-0.61	0.000	0.000	0.00	0.20	0.00
18	1:QZLokaal	Qw1	-0.61	-0.61	0.000	0.000	0.00	0.20	0.00
33	1:QZLokaal	Qw1	-0.61	-0.61	0.000	0.000	0.00	0.20	0.00
44	1:QZLokaal	Qw1	-0.61	-0.61	0.000	0.000	0.00	0.20	0.00
54	1:QZLokaal	Qw1	-0.61	-0.61	0.000	0.000	0.00	0.20	0.00
54	1:QZLokaal	Qw2	-1.63	-1.63	0.000	0.000	0.00	0.20	0.00
44	1:QZLokaal	Qw2	-1.63	-1.63	0.000	0.000	0.00	0.20	0.00
33	1:QZLokaal	Qw2	-1.63	-1.63	0.000	0.000	0.00	0.20	0.00
18	1:QZLokaal	Qw2	-1.63	-1.63	0.000	0.000	0.00	0.20	0.00
69	1:QZLokaal	Qw11	-0.03	-0.03	1.125	0.000	0.00	0.20	0.00
69	1:QZLokaal	Qw12	-0.03	-0.03	0.000	3.900	0.00	0.20	0.00
67	1:QZLokaal	Qw12	-0.03	-0.03	0.000	0.000	0.00	0.20	0.00
65	1:QZLokaal	Qw12	-0.03	-0.03	0.000	0.000	0.00	0.20	0.00
58	1:QZLokaal	Qw12	-0.03	-0.03	0.000	0.000	0.00	0.20	0.00
63	1:QZLokaal	Qw18	-0.38	-0.38	1.126	0.000	0.00	0.20	0.00
61	1:QZLokaal	Qw7	1.02	1.02	0.000	0.000	0.00	0.20	0.00
59	1:QZLokaal	Qw7	1.02	1.02	0.000	0.000	0.00	0.20	0.00
45	1:QZLokaal	Qw7	1.02	1.02	0.000	0.000	0.00	0.20	0.00
1	1:QZLokaal	Qw7	1.02	1.02	0.118	0.000	0.00	0.20	0.00

Onderdeel.....:

REACTIES

B.G:14 Wind van rechts onderdruk C

Kn.	X	Z	M
1	101.35	100.17	
3	0.70	-1.11	
4	0.76	88.41	
5	0.63	1.46	
7	0.40	5.79	
8	105.45	-91.77	
9	0.94	2.82	
10	3.91	-0.35	
52	0.74	-79.05	
214.87 26.35 : Som van de reacties			
-214.87 -26.35 : Som van de belastingen			

BELASTINGEN

B.G:15 Wind van rechts overdruk C

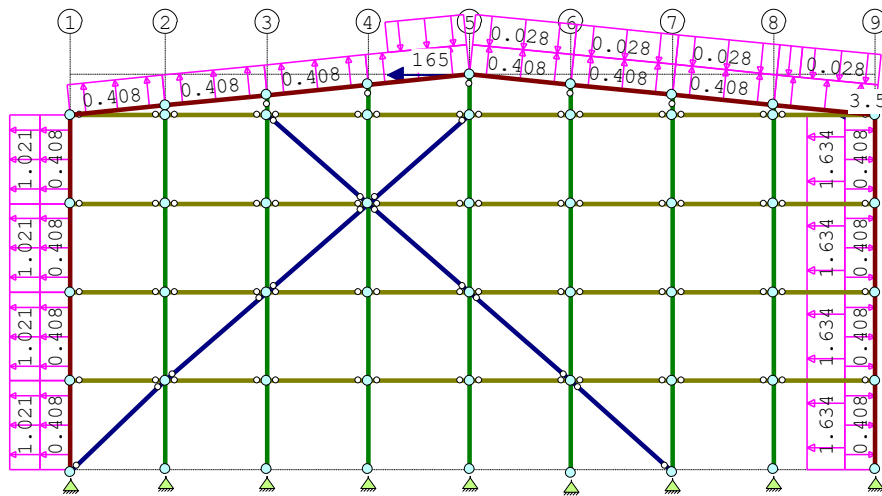

KNOOPBELASTINGEN

B.G:15 Wind van rechts overdruk C

Last	Knoop	Richting	waarde	ψ ₀	ψ ₁	ψ ₂	Opm.
1	6 X		-165.000	0.00	0.20	0.00	*
2	18 X		-3.500	0.00	0.20	0.00	*

Opmerkingen

[*] Deze belasting is handmatig toegevoegd of gewijzigd.

STAAFBELASTINGEN

B.G:15 Wind van rechts overdruk C

Staaft	Type	Index	q1/p/m	q2	A	B	Ψ ₀	Ψ ₁	Ψ ₂
1	1:QZLokaal	Qw8	0.41	0.41	0.118	0.000	0.00	0.20	0.00
45	1:QZLokaal	Qw8	0.41	0.41	0.000	0.000	0.00	0.20	0.00
59	1:QZLokaal	Qw8	0.41	0.41	0.000	0.000	0.00	0.20	0.00
61	1:QZLokaal	Qw8	0.41	0.41	0.000	0.000	0.00	0.20	0.00
57	1:QZLokaal	Qw8	0.41	0.41	0.000	0.000	0.00	0.20	0.00
73	1:QZLokaal	Qw8	0.41	0.41	0.000	0.000	0.00	0.20	0.00
71	1:QZLokaal	Qw8	0.41	0.41	0.000	0.000	0.00	0.20	0.00
63	1:QZLokaal	Qw8	0.41	0.41	0.000	0.000	0.00	0.20	0.00
58	1:QZLokaal	Qw8	0.41	0.41	0.000	0.000	0.00	0.20	0.00
65	1:QZLokaal	Qw8	0.41	0.41	0.000	0.000	0.00	0.20	0.00
67	1:QZLokaal	Qw8	0.41	0.41	0.000	0.000	0.00	0.20	0.00
69	1:QZLokaal	Qw8	0.41	0.41	0.000	0.000	0.00	0.20	0.00
18	1:QZLokaal	Qw8	0.41	0.41	0.000	0.000	0.00	0.20	0.00
33	1:QZLokaal	Qw8	0.41	0.41	0.000	0.000	0.00	0.20	0.00
44	1:QZLokaal	Qw8	0.41	0.41	0.000	0.000	0.00	0.20	0.00
54	1:QZLokaal	Qw8	0.41	0.41	0.000	0.000	0.00	0.20	0.00
54	1:QZLokaal	Qw2	-1.63	-1.63	0.000	0.000	0.00	0.20	0.00
44	1:QZLokaal	Qw2	-1.63	-1.63	0.000	0.000	0.00	0.20	0.00
33	1:QZLokaal	Qw2	-1.63	-1.63	0.000	0.000	0.00	0.20	0.00

Onderdeel.....:

STAAFBELASTINGEN

B.G:15 Wind van rechts overdruk C

Staaft	Type	Index	q1/p/m	q2	A	B	Ψ ₀	Ψ ₁	Ψ ₂
18	1:QZLokaal	Qw2	-1.63	-1.63	0.000	0.000	0.00	0.20	0.00
69	1:QZLokaal	Qw11	-0.03	-0.03	1.125	0.000	0.00	0.20	0.00
69	1:QZLokaal	Qw12	-0.03	-0.03	0.000	3.900	0.00	0.20	0.00
67	1:QZLokaal	Qw12	-0.03	-0.03	0.000	0.000	0.00	0.20	0.00
65	1:QZLokaal	Qw12	-0.03	-0.03	0.000	0.000	0.00	0.20	0.00
58	1:QZLokaal	Qw12	-0.03	-0.03	0.000	0.000	0.00	0.20	0.00
63	1:QZLokaal	Qw18	-0.38	-0.38	1.126	0.000	0.00	0.20	0.00
61	1:QZLokaal	Qw7	1.02	1.02	0.000	0.000	0.00	0.20	0.00
59	1:QZLokaal	Qw7	1.02	1.02	0.000	0.000	0.00	0.20	0.00
45	1:QZLokaal	Qw7	1.02	1.02	0.000	0.000	0.00	0.20	0.00
1	1:QZLokaal	Qw7	1.02	1.02	0.118	0.000	0.00	0.20	0.00

REACTIES

B.G:15 Wind van rechts overdruk C

Kn.	X	Z	M
1	105.17	99.64	
3	0.72	-8.85	
4	0.79	83.06	
5	0.63	-2.10	
7	0.42	-1.61	
8	103.56	-95.26	
9	0.73	-2.35	
10	2.13	-3.08	
52	0.72	-83.65	
214.87			-14.19 : Som van de reacties
-214.87			14.19 : Som van de belastingen

BELASTINGEN

B.G:16 Wind van rechts onderdruk D

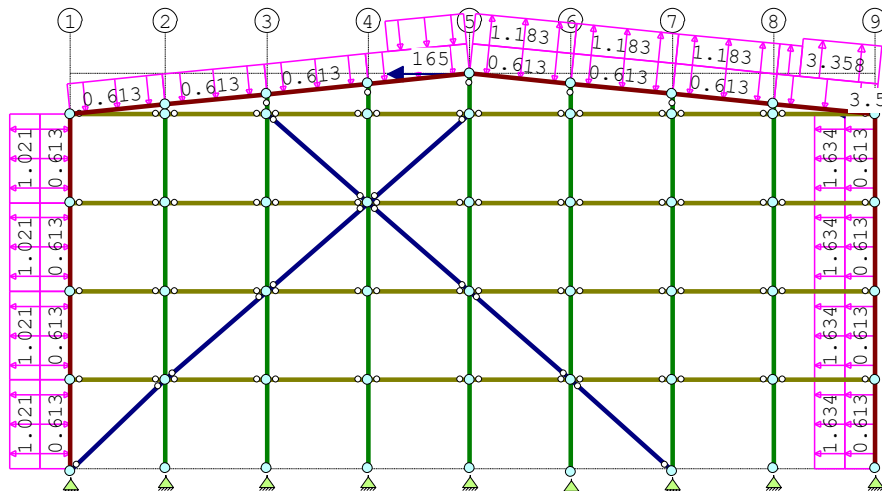

KNOOPBELASTINGEN

B.G:16 Wind van rechts onderdruk D

Last	Knoop	Richting	waarde	Ψ ₀	Ψ ₁	Ψ ₂	Opm.
1	6	X	-165.000	0.00	0.20	0.00	*
2	18	X	-3.500	0.00	0.20	0.00	*

Opmerkingen

[*] Deze belasting is handmatig toegevoegd of gewijzigd.

Onderdeel.....:

STAAFBELASTINGEN

B.G:16 Wind van rechts onderdruk D

StAAF	Type	Index	q1/p/m	q2	A	B	Ψ ₀	Ψ ₁	Ψ ₂
1	1:QZLokaal	Qw1	-0.61	-0.61	0.118	0.000	0.00	0.20	0.00
45	1:QZLokaal	Qw1	-0.61	-0.61	0.000	0.000	0.00	0.20	0.00
59	1:QZLokaal	Qw1	-0.61	-0.61	0.000	0.000	0.00	0.20	0.00
61	1:QZLokaal	Qw1	-0.61	-0.61	0.000	0.000	0.00	0.20	0.00
57	1:QZLokaal	Qw1	-0.61	-0.61	0.000	0.000	0.00	0.20	0.00
73	1:QZLokaal	Qw1	-0.61	-0.61	0.000	0.000	0.00	0.20	0.00
71	1:QZLokaal	Qw1	-0.61	-0.61	0.000	0.000	0.00	0.20	0.00
63	1:QZLokaal	Qw1	-0.61	-0.61	0.000	0.000	0.00	0.20	0.00
58	1:QZLokaal	Qw1	-0.61	-0.61	0.000	0.000	0.00	0.20	0.00
65	1:QZLokaal	Qw1	-0.61	-0.61	0.000	0.000	0.00	0.20	0.00
67	1:QZLokaal	Qw1	-0.61	-0.61	0.000	0.000	0.00	0.20	0.00
69	1:QZLokaal	Qw1	-0.61	-0.61	0.000	0.000	0.00	0.20	0.00
18	1:QZLokaal	Qw1	-0.61	-0.61	0.000	0.000	0.00	0.20	0.00
33	1:QZLokaal	Qw1	-0.61	-0.61	0.000	0.000	0.00	0.20	0.00
44	1:QZLokaal	Qw1	-0.61	-0.61	0.000	0.000	0.00	0.20	0.00
54	1:QZLokaal	Qw1	-0.61	-0.61	0.000	0.000	0.00	0.20	0.00
54	1:QZLokaal	Qw2	-1.63	-1.63	0.000	0.000	0.00	0.20	0.00
44	1:QZLokaal	Qw2	-1.63	-1.63	0.000	0.000	0.00	0.20	0.00
33	1:QZLokaal	Qw2	-1.63	-1.63	0.000	0.000	0.00	0.20	0.00
18	1:QZLokaal	Qw2	-1.63	-1.63	0.000	0.000	0.00	0.20	0.00
69	1:QZLokaal	Qw15	3.36	3.36	1.125	0.000	0.00	0.20	0.00
69	1:QZLokaal	Qw16	1.18	1.18	0.000	3.900	0.00	0.20	0.00
67	1:QZLokaal	Qw16	1.18	1.18	0.000	0.000	0.00	0.20	0.00
65	1:QZLokaal	Qw16	1.18	1.18	0.000	0.000	0.00	0.20	0.00
58	1:QZLokaal	Qw16	1.18	1.18	0.000	0.000	0.00	0.20	0.00
63	1:QZLokaal	Qw18	-0.38	-0.38	1.126	0.000	0.00	0.20	0.00
61	1:QZLokaal	Qw7	1.02	1.02	0.000	0.000	0.00	0.20	0.00
59	1:QZLokaal	Qw7	1.02	1.02	0.000	0.000	0.00	0.20	0.00
45	1:QZLokaal	Qw7	1.02	1.02	0.000	0.000	0.00	0.20	0.00
1	1:QZLokaal	Qw7	1.02	1.02	0.118	0.000	0.00	0.20	0.00

REACTIES

B.G:16 Wind van rechts onderdruk D

Kn.	X	Z	M
1	99.66	98.49	
3	0.69	-1.02	
4	0.75	86.59	
5	0.61	1.18	
7	0.37	-0.69	
8	104.01	-95.66	
9	0.92	-7.55	
10	3.89	-8.30	
52	0.71	-79.34	
211.61			-6.31 : Som van de reacties
-211.61			6.31 : Som van de belastingen

Onderdeel.....:

BELASTINGEN

B.G:17 Wind van rechts overdruk D

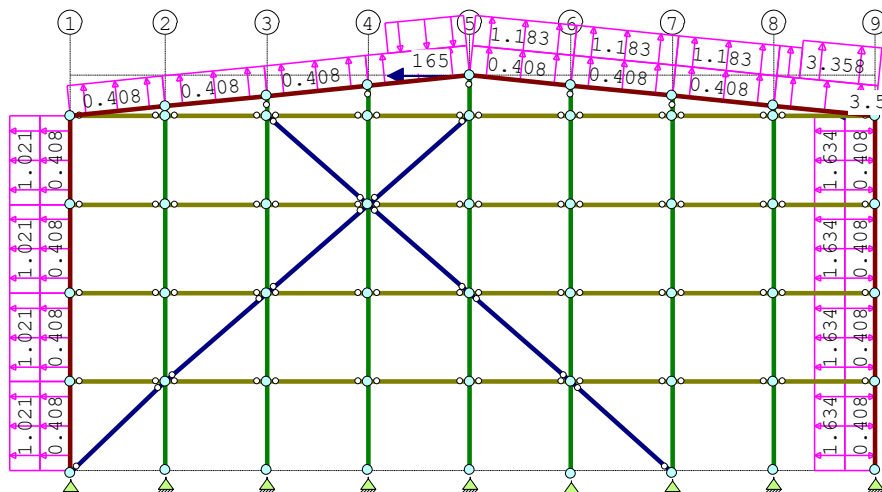

KNOOPBELASTINGEN

B.G:17 Wind van rechts overdruk D

Last	Knoop	Richting	waarde	Ψ ₀	Ψ ₁	Ψ ₂	Opm.
1	6	X	-165.000	0.00	0.20	0.00	*
2	18	X	-3.500	0.00	0.20	0.00	*

Opmerkingen

[*] Deze belasting is handmatig toegevoegd of gewijzigd.

STAAFBELASTINGEN

B.G:17 Wind van rechts overdruk D

Staaftype	Type	Index	q1/p/m	q2	A	B	Ψ_0	Ψ_1	Ψ_2
1	1:QZLokaal	Qw8	0.41	0.41	0.118	0.000	0.00	0.20	0.00
45	1:QZLokaal	Qw8	0.41	0.41	0.000	0.000	0.00	0.20	0.00
59	1:QZLokaal	Qw8	0.41	0.41	0.000	0.000	0.00	0.20	0.00
61	1:QZLokaal	Qw8	0.41	0.41	0.000	0.000	0.00	0.20	0.00
57	1:QZLokaal	Qw8	0.41	0.41	0.000	0.000	0.00	0.20	0.00
73	1:QZLokaal	Qw8	0.41	0.41	0.000	0.000	0.00	0.20	0.00
71	1:QZLokaal	Qw8	0.41	0.41	0.000	0.000	0.00	0.20	0.00
63	1:QZLokaal	Qw8	0.41	0.41	0.000	0.000	0.00	0.20	0.00
58	1:QZLokaal	Qw8	0.41	0.41	0.000	0.000	0.00	0.20	0.00
65	1:QZLokaal	Qw8	0.41	0.41	0.000	0.000	0.00	0.20	0.00
67	1:QZLokaal	Qw8	0.41	0.41	0.000	0.000	0.00	0.20	0.00
69	1:QZLokaal	Qw8	0.41	0.41	0.000	0.000	0.00	0.20	0.00
18	1:QZLokaal	Qw8	0.41	0.41	0.000	0.000	0.00	0.20	0.00
33	1:QZLokaal	Qw8	0.41	0.41	0.000	0.000	0.00	0.20	0.00
44	1:QZLokaal	Qw8	0.41	0.41	0.000	0.000	0.00	0.20	0.00
54	1:QZLokaal	Qw8	0.41	0.41	0.000	0.000	0.00	0.20	0.00
54	1:QZLokaal	Qw2	-1.63	-1.63	0.000	0.000	0.00	0.20	0.00
44	1:QZLokaal	Qw2	-1.63	-1.63	0.000	0.000	0.00	0.20	0.00
33	1:QZLokaal	Qw2	-1.63	-1.63	0.000	0.000	0.00	0.20	0.00
18	1:QZLokaal	Qw2	-1.63	-1.63	0.000	0.000	0.00	0.20	0.00
69	1:QZLokaal	Qw15	3.36	3.36	1.125	0.000	0.00	0.20	0.00
69	1:QZLokaal	Qw16	1.18	1.18	0.000	3.900	0.00	0.20	0.00
67	1:QZLokaal	Qw16	1.18	1.18	0.000	0.000	0.00	0.20	0.00
65	1:QZLokaal	Qw16	1.18	1.18	0.000	0.000	0.00	0.20	0.00
58	1:QZLokaal	Qw16	1.18	1.18	0.000	0.000	0.00	0.20	0.00
63	1:QZLokaal	Qw18	-0.38	-0.38	1.126	0.000	0.00	0.20	0.00
61	1:QZLokaal	Qw7	1.02	1.02	0.000	0.000	0.00	0.20	0.00
59	1:QZLokaal	Qw7	1.02	1.02	0.000	0.000	0.00	0.20	0.00
45	1:QZLokaal	Qw7	1.02	1.02	0.000	0.000	0.00	0.20	0.00
1	1:QZLokaal	Qw7	1.02	1.02	0.118	0.000	0.00	0.20	0.00

Onderdeel.....:

REACTIES

B.G:17 Wind van rechts overdruk D

Kn.	X	Z	M
1	103.47	97.96	
3	0.70	-8.75	
4	0.78	81.25	
5	0.61	-2.38	
7	0.39	-8.10	
8	102.12	-99.14	
9	0.72	-12.72	
10	2.12	-11.03	
52	0.70	-83.93	
211.61		-46.85	: Som van de reacties
-211.61		46.85	: Som van de belastingen

BELASTINGEN

B.G:18 SNEEUW

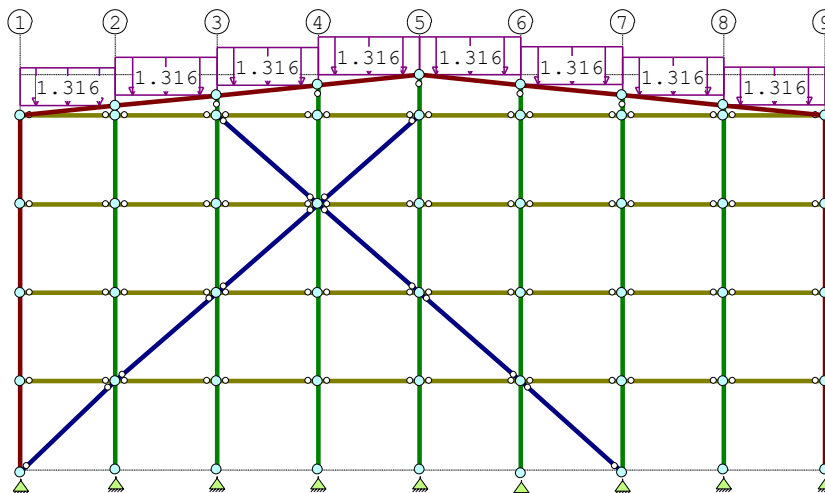

STAAFBELASTINGEN

B.G:18 SNEEUW

Staaftype	Type	q1/p/m	q2	A	B	Ψ_0	Ψ_1	Ψ_2
57	3:QZgeProj.	-1.32	-1.32	0.000	0.000	1.00	0.90	0.80
73	3:QZgeProj.	-1.32	-1.32	0.000	0.000	1.00	0.90	0.80
71	3:QZgeProj.	-1.32	-1.32	0.000	0.000	1.00	0.90	0.80
63	3:QZgeProj.	-1.32	-1.32	0.000	0.000	1.00	0.90	0.80
58	3:QZgeProj.	-1.32	-1.32	0.000	0.000	1.00	0.90	0.80
65	3:QZgeProj.	-1.32	-1.32	0.000	0.000	1.00	0.90	0.80
67	3:QZgeProj.	-1.32	-1.32	0.000	0.000	1.00	0.90	0.80
69	3:QZgeProj.	-1.32	-1.32	0.000	0.000	1.00	0.90	0.80

REACTIES

B.G:18 SNEEUW

Kn.	X	Z	M
1	0.51	3.24	
3	0.00	6.73	
4	-0.00	6.25	
5	0.00	6.34	
7	0.00	6.58	
8	-0.52	6.94	
9	-0.00	7.00	
10	0.01	2.97	
52	0.00	6.18	
0.00		52.25	: Som van de reacties

Onderdeel....:

REACTIES

B.G:18 SNEUW

Kn.	X	Z	M
0.00		-52.25	: Som van de belastingen

BELASTINGEN

B.G:19 Knik

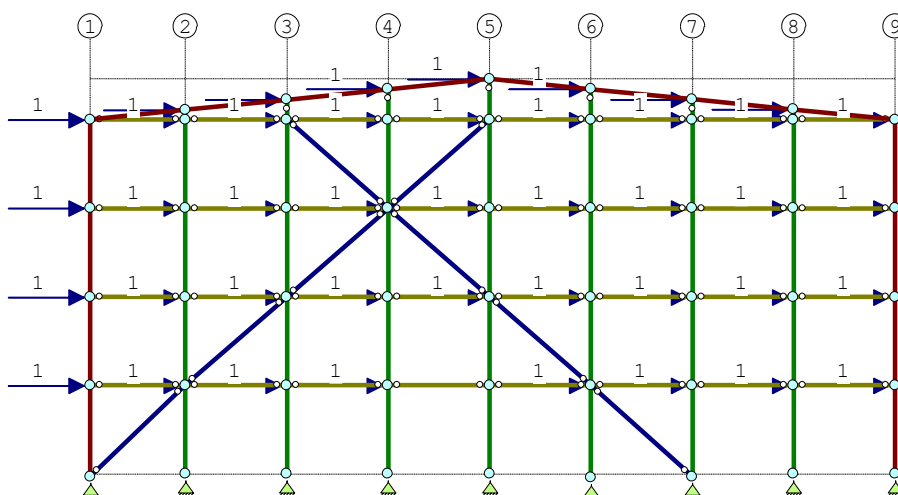

KNOOPBELASTINGEN

B.G:19 Knik

Last	Knoop	Richting	waarde	Ψ_0	Ψ_1	Ψ_2
1	2	X	1.000			
2	6	X	1.000			
3	11	X	1.000			
4	12	X	1.000			
5	13	X	1.000			
6	14	X	1.000			
7	15	X	1.000			
8	16	X	1.000			
9	17	X	1.000			
10	18	X	1.000			
11	19	X	1.000			
12	20	X	1.000			
13	21	X	1.000			
14	22	X	1.000			
15	23	X	1.000			
16	24	X	1.000			
17	25	X	1.000			
18	26	X	1.000			
19	27	X	1.000			
20	28	X	1.000			
21	29	X	1.000			
22	30	X	1.000			
23	31	X	1.000			
24	32	X	1.000			
25	33	X	1.000			
26	34	X	1.000			
27	35	X	1.000			
28	36	X	1.000			
29	37	X	1.000			
30	38	X	1.000			
31	39	X	1.000			
32	40	X	1.000			
33	41	X	1.000			
34	42	X	1.000			
35	43	X	1.000			
36	44	X	1.000			
37	45	X	1.000			
38	46	X	1.000			

Onderdeel....:

KNOOPBELASTINGEN

B.G:19 Knik

Last	Knoop	Richting	waarde	Ψ_0	Ψ_1	Ψ_2
39	47	X	1.000			
40	48	X	1.000			
41	49	X	1.000			
42	50	X	1.000			

REACTIES

B.G:19 Knik

Kn.	X	Z	M
1	-19.92	-19.14	
3	-0.12	3.92	
4	-0.24	-4.05	
5	-0.19	0.57	
7	-0.05	-3.67	
8	-21.11	18.78	
9	-0.17	-0.14	
10	-0.01	0.06	
52	-0.21	3.67	
	-42.00	0.00	: Som van de reacties
	42.00	0.00	: Som van de belastingen

BELASTINGCOMBINATIES

BC	Type				
1	Fund.	1.35	$G_{k,1}$		
2	Fund.	0.90	$G_{k,1}$		
3	Fund.	1.35	$G_{k,1}$	+ 1.50 Ψ_0	$Q_{k,18}$
4	Fund.	1.20	$G_{k,1}$	+ 1.50	$Q_{k,2}$
5	Fund.	1.20	$G_{k,1}$	+ 1.50	$Q_{k,3}$
6	Fund.	1.20	$G_{k,1}$	+ 1.50	$Q_{k,4}$
7	Fund.	1.20	$G_{k,1}$	+ 1.50	$Q_{k,5}$
8	Fund.	1.20	$G_{k,1}$	+ 1.50	$Q_{k,6}$
9	Fund.	1.20	$G_{k,1}$	+ 1.50	$Q_{k,7}$
10	Fund.	1.20	$G_{k,1}$	+ 1.50	$Q_{k,8}$
11	Fund.	1.20	$G_{k,1}$	+ 1.50	$Q_{k,9}$
12	Fund.	1.20	$G_{k,1}$	+ 1.50	$Q_{k,10}$
13	Fund.	1.20	$G_{k,1}$	+ 1.50	$Q_{k,11}$
14	Fund.	1.20	$G_{k,1}$	+ 1.50	$Q_{k,12}$
15	Fund.	1.20	$G_{k,1}$	+ 1.50	$Q_{k,13}$
16	Fund.	1.20	$G_{k,1}$	+ 1.50	$Q_{k,14}$
17	Fund.	1.20	$G_{k,1}$	+ 1.50	$Q_{k,15}$
18	Fund.	1.20	$G_{k,1}$	+ 1.50	$Q_{k,16}$
19	Fund.	1.20	$G_{k,1}$	+ 1.50	$Q_{k,17}$
20	Fund.	1.20	$G_{k,1}$	+ 1.50	$Q_{k,18}$
21	Fund.	0.90	$G_{k,1}$	+ 1.50	$Q_{k,2}$
22	Fund.	0.90	$G_{k,1}$	+ 1.50	$Q_{k,3}$
23	Fund.	0.90	$G_{k,1}$	+ 1.50	$Q_{k,4}$
24	Fund.	0.90	$G_{k,1}$	+ 1.50	$Q_{k,5}$
25	Fund.	0.90	$G_{k,1}$	+ 1.50	$Q_{k,6}$
26	Fund.	0.90	$G_{k,1}$	+ 1.50	$Q_{k,7}$
27	Fund.	0.90	$G_{k,1}$	+ 1.50	$Q_{k,8}$
28	Fund.	0.90	$G_{k,1}$	+ 1.50	$Q_{k,9}$
29	Fund.	0.90	$G_{k,1}$	+ 1.50	$Q_{k,10}$
30	Fund.	0.90	$G_{k,1}$	+ 1.50	$Q_{k,11}$
31	Fund.	0.90	$G_{k,1}$	+ 1.50	$Q_{k,12}$
32	Fund.	0.90	$G_{k,1}$	+ 1.50	$Q_{k,13}$
33	Fund.	0.90	$G_{k,1}$	+ 1.50	$Q_{k,14}$
34	Fund.	0.90	$G_{k,1}$	+ 1.50	$Q_{k,15}$
35	Fund.	0.90	$G_{k,1}$	+ 1.50	$Q_{k,16}$
36	Fund.	0.90	$G_{k,1}$	+ 1.50	$Q_{k,17}$

Onderdeel.....:

BELASTINGCOMBINATIES

BC	Type					
37	Fund.	0.90	$G_{k,1}$	+ 1.50 Ψ_0	$Q_{k,18}$	
38	Fund.	0.90	$G_{k,1}$	+ 1.50	$Q_{k,18}$	
39	Fund.	1.20	$G_{k,1}$	+ 1.50	$Q_{k,2}$	+ 1.50 Ψ_0 $Q_{k,18}$
40	Fund.	1.20	$G_{k,1}$	+ 1.50	$Q_{k,3}$	+ 1.50 Ψ_0 $Q_{k,18}$
41	Fund.	1.20	$G_{k,1}$	+ 1.50	$Q_{k,4}$	+ 1.50 Ψ_0 $Q_{k,18}$
42	Fund.	1.20	$G_{k,1}$	+ 1.50	$Q_{k,5}$	+ 1.50 Ψ_0 $Q_{k,18}$
43	Fund.	1.20	$G_{k,1}$	+ 1.50	$Q_{k,6}$	+ 1.50 Ψ_0 $Q_{k,18}$
44	Fund.	1.20	$G_{k,1}$	+ 1.50	$Q_{k,7}$	+ 1.50 Ψ_0 $Q_{k,18}$
45	Fund.	1.20	$G_{k,1}$	+ 1.50	$Q_{k,8}$	+ 1.50 Ψ_0 $Q_{k,18}$
46	Fund.	1.20	$G_{k,1}$	+ 1.50	$Q_{k,9}$	+ 1.50 Ψ_0 $Q_{k,18}$
47	Fund.	1.20	$G_{k,1}$	+ 1.50	$Q_{k,10}$	+ 1.50 Ψ_0 $Q_{k,18}$
48	Fund.	1.20	$G_{k,1}$	+ 1.50	$Q_{k,11}$	+ 1.50 Ψ_0 $Q_{k,18}$
49	Fund.	1.20	$G_{k,1}$	+ 1.50	$Q_{k,12}$	+ 1.50 Ψ_0 $Q_{k,18}$

50 Fund.	1.20	$G_{k,1}$	+	1.50	$Q_{k,13}$	+	1.50	Ψ_0	$Q_{k,18}$
51 Fund.	1.20	$G_{k,1}$	+	1.50	$Q_{k,14}$	+	1.50	Ψ_0	$Q_{k,18}$
52 Fund.	1.20	$G_{k,1}$	+	1.50	$Q_{k,15}$	+	1.50	Ψ_0	$Q_{k,18}$
53 Fund.	1.20	$G_{k,1}$	+	1.50	$Q_{k,16}$	+	1.50	Ψ_0	$Q_{k,18}$
54 Fund.	1.20	$G_{k,1}$	+	1.50	$Q_{k,17}$	+	1.50	Ψ_0	$Q_{k,18}$
55 Fund.	0.90	$G_{k,1}$	+	1.50	$Q_{k,2}$	+	1.50	Ψ_0	$Q_{k,18}$
56 Fund.	0.90	$G_{k,1}$	+	1.50	$Q_{k,3}$	+	1.50	Ψ_0	$Q_{k,18}$
57 Fund.	0.90	$G_{k,1}$	+	1.50	$Q_{k,4}$	+	1.50	Ψ_0	$Q_{k,18}$
58 Fund.	0.90	$G_{k,1}$	+	1.50	$Q_{k,5}$	+	1.50	Ψ_0	$Q_{k,18}$
59 Fund.	0.90	$G_{k,1}$	+	1.50	$Q_{k,6}$	+	1.50	Ψ_0	$Q_{k,18}$
60 Fund.	0.90	$G_{k,1}$	+	1.50	$Q_{k,7}$	+	1.50	Ψ_0	$Q_{k,18}$
61 Fund.	0.90	$G_{k,1}$	+	1.50	$Q_{k,8}$	+	1.50	Ψ_0	$Q_{k,18}$
62 Fund.	0.90	$G_{k,1}$	+	1.50	$Q_{k,9}$	+	1.50	Ψ_0	$Q_{k,18}$
63 Fund.	0.90	$G_{k,1}$	+	1.50	$Q_{k,10}$	+	1.50	Ψ_0	$Q_{k,18}$
64 Fund.	0.90	$G_{k,1}$	+	1.50	$Q_{k,11}$	+	1.50	Ψ_0	$Q_{k,18}$
65 Fund.	0.90	$G_{k,1}$	+	1.50	$Q_{k,12}$	+	1.50	Ψ_0	$Q_{k,18}$
66 Fund.	0.90	$G_{k,1}$	+	1.50	$Q_{k,13}$	+	1.50	Ψ_0	$Q_{k,18}$
67 Fund.	0.90	$G_{k,1}$	+	1.50	$Q_{k,14}$	+	1.50	Ψ_0	$Q_{k,18}$
68 Fund.	0.90	$G_{k,1}$	+	1.50	$Q_{k,15}$	+	1.50	Ψ_0	$Q_{k,18}$
69 Fund.	0.90	$G_{k,1}$	+	1.50	$Q_{k,16}$	+	1.50	Ψ_0	$Q_{k,18}$
70 Fund.	0.90	$G_{k,1}$	+	1.50	$Q_{k,17}$	+	1.50	Ψ_0	$Q_{k,18}$
71 Kar.	1.00	$G_{k,1}$	+	1.00	$Q_{k,2}$				
72 Kar.	1.00	$G_{k,1}$	+	1.00	$Q_{k,3}$				
73 Kar.	1.00	$G_{k,1}$	+	1.00	$Q_{k,4}$				
74 Kar.	1.00	$G_{k,1}$	+	1.00	$Q_{k,5}$				
75 Kar.	1.00	$G_{k,1}$	+	1.00	$Q_{k,6}$				
76 Kar.	1.00	$G_{k,1}$	+	1.00	$Q_{k,7}$				
77 Kar.	1.00	$G_{k,1}$	+	1.00	$Q_{k,8}$				
78 Kar.	1.00	$G_{k,1}$	+	1.00	$Q_{k,9}$				
79 Kar.	1.00	$G_{k,1}$	+	1.00	$Q_{k,10}$				
80 Kar.	1.00	$G_{k,1}$	+	1.00	$Q_{k,11}$				
81 Kar.	1.00	$G_{k,1}$	+	1.00	$Q_{k,12}$				
82 Kar.	1.00	$G_{k,1}$	+	1.00	$Q_{k,13}$				
83 Kar.	1.00	$G_{k,1}$	+	1.00	$Q_{k,14}$				
84 Kar.	1.00	$G_{k,1}$	+	1.00	$Q_{k,15}$				
85 Kar.	1.00	$G_{k,1}$	+	1.00	$Q_{k,16}$				
86 Kar.	1.00	$G_{k,1}$	+	1.00	$Q_{k,17}$				
87 Kar.	1.00	$G_{k,1}$	+	1.00	$Q_{k,18}$				
88 Kar.	1.00	$G_{k,1}$	+	1.00	$Q_{k,2}$	+	1.00	Ψ_0	$Q_{k,18}$
89 Kar.	1.00	$G_{k,1}$	+	1.00	$Q_{k,3}$	+	1.00	Ψ_0	$Q_{k,18}$
90 Kar.	1.00	$G_{k,1}$	+	1.00	$Q_{k,4}$	+	1.00	Ψ_0	$Q_{k,18}$
91 Kar.	1.00	$G_{k,1}$	+	1.00	$Q_{k,5}$	+	1.00	Ψ_0	$Q_{k,18}$

Onderdeel.....:

BELASTINGCOMBINATIES

BC Type									
92 Kar.	1.00	$G_{k,1}$	+	1.00	$Q_{k,6}$	+	1.00	Ψ_0	$Q_{k,18}$
93 Kar.	1.00	$G_{k,1}$	+	1.00	$Q_{k,7}$	+	1.00	Ψ_0	$Q_{k,18}$
94 Kar.	1.00	$G_{k,1}$	+	1.00	$Q_{k,8}$	+	1.00	Ψ_0	$Q_{k,18}$
95 Kar.	1.00	$G_{k,1}$	+	1.00	$Q_{k,9}$	+	1.00	Ψ_0	$Q_{k,18}$
96 Kar.	1.00	$G_{k,1}$	+	1.00	$Q_{k,10}$	+	1.00	Ψ_0	$Q_{k,18}$
97 Kar.	1.00	$G_{k,1}$	+	1.00	$Q_{k,11}$	+	1.00	Ψ_0	$Q_{k,18}$
98 Kar.	1.00	$G_{k,1}$	+	1.00	$Q_{k,12}$	+	1.00	Ψ_0	$Q_{k,18}$
99 Kar.	1.00	$G_{k,1}$	+	1.00	$Q_{k,13}$	+	1.00	Ψ_0	$Q_{k,18}$
100 Kar.	1.00	$G_{k,1}$	+	1.00	$Q_{k,14}$	+	1.00	Ψ_0	$Q_{k,18}$
101 Kar.	1.00	$G_{k,1}$	+	1.00	$Q_{k,15}$	+	1.00	Ψ_0	$Q_{k,18}$
102 Kar.	1.00	$G_{k,1}$	+	1.00	$Q_{k,16}$	+	1.00	Ψ_0	$Q_{k,18}$
103 Kar.	1.00	$G_{k,1}$	+	1.00	$Q_{k,17}$	+	1.00	Ψ_0	$Q_{k,18}$
104 Quas.	1.00	$G_{k,1}$							
105 Quas.	1.00	$G_{k,1}$	+	1.00	Ψ_2	$Q_{k,18}$			
106 Freq.	1.00	$G_{k,1}$							
107 Freq.	1.00	$G_{k,1}$	+	1.00	Ψ_1	$Q_{k,2}$			
108 Freq.	1.00	$G_{k,1}$	+	1.00	Ψ_1	$Q_{k,3}$			
109 Freq.	1.00	$G_{k,1}$	+	1.00	Ψ_1	$Q_{k,4}$			
110 Freq.	1.00	$G_{k,1}$	+	1.00	Ψ_1	$Q_{k,5}$			
111 Freq.	1.00	$G_{k,1}$	+	1.00	Ψ_1	$Q_{k,6}$			
112 Freq.	1.00	$G_{k,1}$	+	1.00	Ψ_1	$Q_{k,7}$			
113 Freq.	1.00	$G_{k,1}$	+	1.00	Ψ_1	$Q_{k,8}$			
114 Freq.	1.00	$G_{k,1}$	+	1.00	Ψ_1	$Q_{k,9}$			

115 Freq.	1.00	$G_{k,1}$	+	1.00	Ψ_1	$Q_{k,10}$	
116 Freq.	1.00	$G_{k,1}$	+	1.00	Ψ_1	$Q_{k,11}$	
117 Freq.	1.00	$G_{k,1}$	+	1.00	Ψ_1	$Q_{k,12}$	
118 Freq.	1.00	$G_{k,1}$	+	1.00	Ψ_1	$Q_{k,13}$	
119 Freq.	1.00	$G_{k,1}$	+	1.00	Ψ_1	$Q_{k,14}$	
120 Freq.	1.00	$G_{k,1}$	+	1.00	Ψ_1	$Q_{k,15}$	
121 Freq.	1.00	$G_{k,1}$	+	1.00	Ψ_1	$Q_{k,16}$	
122 Freq.	1.00	$G_{k,1}$	+	1.00	Ψ_1	$Q_{k,17}$	
123 Freq.	1.00	$G_{k,1}$	+	1.00	Ψ_1	$Q_{k,18}$	
124 Freq.	1.00	$G_{k,1}$	+	1.00	Ψ_1	$Q_{k,2}$	+ 1.00 Ψ_2 $Q_{k,18}$
125 Freq.	1.00	$G_{k,1}$	+	1.00	Ψ_1	$Q_{k,3}$	+ 1.00 Ψ_2 $Q_{k,18}$
126 Freq.	1.00	$G_{k,1}$	+	1.00	Ψ_1	$Q_{k,4}$	+ 1.00 Ψ_2 $Q_{k,18}$
127 Freq.	1.00	$G_{k,1}$	+	1.00	Ψ_1	$Q_{k,5}$	+ 1.00 Ψ_2 $Q_{k,18}$
128 Freq.	1.00	$G_{k,1}$	+	1.00	Ψ_1	$Q_{k,6}$	+ 1.00 Ψ_2 $Q_{k,18}$
129 Freq.	1.00	$G_{k,1}$	+	1.00	Ψ_1	$Q_{k,7}$	+ 1.00 Ψ_2 $Q_{k,18}$
130 Freq.	1.00	$G_{k,1}$	+	1.00	Ψ_1	$Q_{k,8}$	+ 1.00 Ψ_2 $Q_{k,18}$
131 Freq.	1.00	$G_{k,1}$	+	1.00	Ψ_1	$Q_{k,9}$	+ 1.00 Ψ_2 $Q_{k,18}$
132 Freq.	1.00	$G_{k,1}$	+	1.00	Ψ_1	$Q_{k,10}$	+ 1.00 Ψ_2 $Q_{k,18}$
133 Freq.	1.00	$G_{k,1}$	+	1.00	Ψ_1	$Q_{k,11}$	+ 1.00 Ψ_2 $Q_{k,18}$
134 Freq.	1.00	$G_{k,1}$	+	1.00	Ψ_1	$Q_{k,12}$	+ 1.00 Ψ_2 $Q_{k,18}$
135 Freq.	1.00	$G_{k,1}$	+	1.00	Ψ_1	$Q_{k,13}$	+ 1.00 Ψ_2 $Q_{k,18}$
136 Freq.	1.00	$G_{k,1}$	+	1.00	Ψ_1	$Q_{k,14}$	+ 1.00 Ψ_2 $Q_{k,18}$
137 Freq.	1.00	$G_{k,1}$	+	1.00	Ψ_1	$Q_{k,15}$	+ 1.00 Ψ_2 $Q_{k,18}$
138 Freq.	1.00	$G_{k,1}$	+	1.00	Ψ_1	$Q_{k,16}$	+ 1.00 Ψ_2 $Q_{k,18}$
139 Freq.	1.00	$G_{k,1}$	+	1.00	Ψ_1	$Q_{k,17}$	+ 1.00 Ψ_2 $Q_{k,18}$
140 Blij.	1.00	$G_{k,1}$					

Onderdeel.....:

GUNSTIGE WERKING PERMANENTE BELASTINGEN

BC Staven met gunstige werking

- 1 Geen
- 2 Alle staven de factor:0.90
- 3 Geen
- 4 Geen
- 5 Geen
- 6 Geen
- 7 Geen
- 8 Geen
- 9 Geen
- 10 Geen
- 11 Geen
- 12 Geen
- 13 Geen
- 14 Geen
- 15 Geen
- 16 Geen
- 17 Geen
- 18 Geen
- 19 Geen
- 20 Geen
- 21 Alle staven de factor:0.90
- 22 Alle staven de factor:0.90
- 23 Alle staven de factor:0.90
- 24 Alle staven de factor:0.90
- 25 Alle staven de factor:0.90
- 26 Alle staven de factor:0.90
- 27 Alle staven de factor:0.90
- 28 Alle staven de factor:0.90
- 29 Alle staven de factor:0.90
- 30 Alle staven de factor:0.90
- 31 Alle staven de factor:0.90
- 32 Alle staven de factor:0.90
- 33 Alle staven de factor:0.90
- 34 Alle staven de factor:0.90
- 35 Alle staven de factor:0.90
- 36 Alle staven de factor:0.90
- 37 Alle staven de factor:0.90
- 38 Alle staven de factor:0.90
- 39 Geen
- 40 Geen
- 41 Geen
- 42 Geen
- 43 Geen
- 44 Geen
- 45 Geen
- 46 Geen
- 47 Geen
- 48 Geen
- 49 Geen

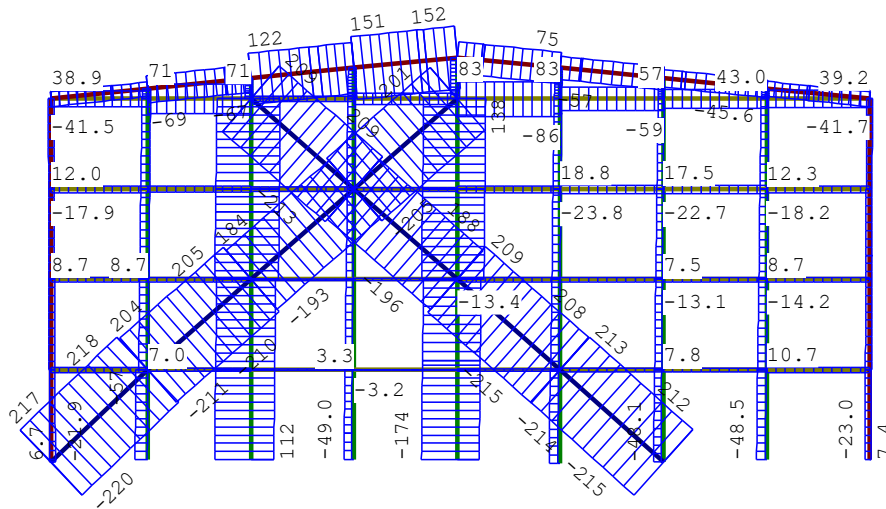

REACTIES

Fundamentele combinatie

Kn.	X-min	X-max	Z-min	Z-max	M-min	M-max
1	-162.87	162.18	-151.73	170.16		
3	-1.12	1.10	2.62	62.21		
4	-1.25	1.22	-111.71	176.41		
5	-0.98	0.98	13.00	49.01		
7	-0.67	0.68	12.32	54.15		
8	-160.47	158.78	-124.24	188.58		
9	-1.18	1.44	5.53	48.45		
10	-3.74	5.88	-7.40	22.95		
52	-1.11	1.14	-107.47	173.76		

Onderdeel.....:

OMHULLENDE VAN DE KARAKTERISTIEKE COMBINATIES

VERPLAATSINGEN

[mm]

Karakteristieke combinatie

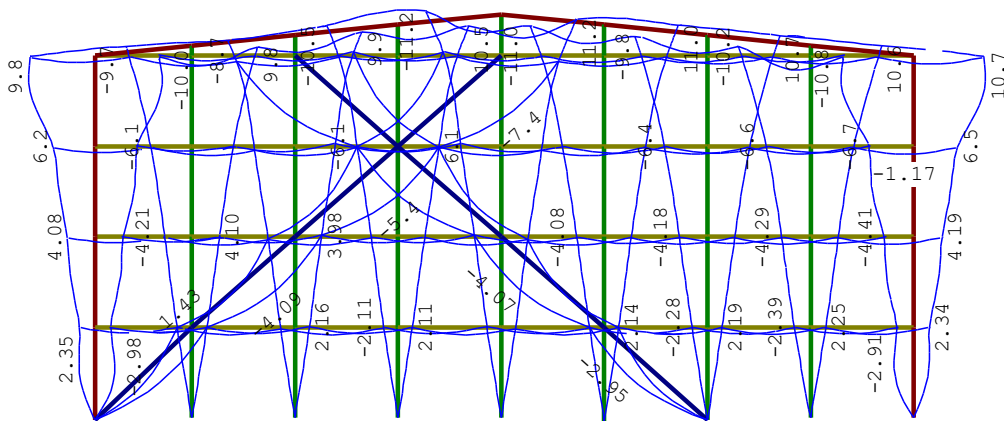

STAALPROFIELEN - ALGEMENE GEGEVENS

Stabiliteit: Classificatie gehele constructie: Ongeschoord
 Belastinggeval m.b.t. bepaling kniklengte: 19=Knik
 Aanpassing inkl. parameter C : Steunpunten

Tweede-orde-effect:
 Aan te houden verhouding n/(n-1) voor steunmomenten en verplaatsingen: 1.10

Doorbuiging en verplaatsing:
 Aantal bouwlagen: 1
 Gebouwtype: Overig
 Toel. horiz. verplaatsing gehele gebouw: h/300
 Kleinste gevelhoogte [m]: 0.0

PROFIEL/MATERIAAL

P/M nr.	Profielnaam	Vloei-sp. [N/mm ²]	Productie methode	Min. drsn. klasse
1	HEA160	235	Gewalst	1
2	IPE500	355	Gewalst	1
3	K150/100/4CF	235	Koudgevormd	1
4	K150/150/5CF	235	Koudgevormd	1

Partiële veiligheidsfactoren:

Gamma M;0 : 1.00 Gamma M;1 : 1.00

KNIKSTABILITEIT

Staaf	l _{sys} [m]	Classif. y sterke as	l _{knik;y} [m]	Extra		l _{knik;z} [m]	Extra	
				aanp. y [kN]	Classif. z zwakke as		aanp. z [kN]	
1	4.493	Ongeschoord	4.490*	0.0	Geschoord	4.493	0.0	
2	2.000	Ongeschoord	2.000*	0.0	Geschoord	2.000	0.0	
3	4.700	Geschoord	4.700	0.0	Geschoord	4.700	0.0	
4	4.375	Ongeschoord	4.380*	0.0	Geschoord	4.375	0.0	
5	5.000	Geschoord	5.000	0.0	Geschoord	5.000	0.0	
6	4.375	Ongeschoord	4.380*	0.0	Geschoord	4.375	0.0	
7	5.000	Geschoord	5.000	0.0	Geschoord	5.000	0.0	
8	4.375	Ongeschoord	4.380*	0.0	Geschoord	4.375	0.0	
9	5.000	Geschoord	5.000	0.0	Geschoord	5.000	0.0	
10	4.375	Ongeschoord	4.380*	0.0	Geschoord	4.375	0.0	
11	5.000	Geschoord	5.000	0.0	Geschoord	5.000	0.0	
12	4.375	Ongeschoord	4.380*	0.0	Geschoord	4.375	0.0	
13	5.000	Geschoord	5.000	0.0	Geschoord	5.000	0.0	
14	4.375	Ongeschoord	4.380*	0.0	Geschoord	4.375	0.0	
15	5.000	Geschoord	5.000*	0.0	Geschoord	5.000	0.0	

Onderdeel....:

KNIKSTABILITEIT

Staaf	l _{sys} [m]	Classif. y sterke as	l _{knik;y} [m]	Extra		l _{knik;z} [m]	Extra	
				aanp. y [kN]	Classif. z zwakke as		aanp. z [kN]	
16	4.375	Ongeschoord	4.380*	0.0	Geschoord	4.375	0.0	
17	5.000	Geschoord	5.000*	0.0	Geschoord	5.000	0.0	
18	4.375	Ongeschoord	4.380*	0.0	Geschoord	4.375	0.0	
19	4.375	Ongeschoord	4.380*	0.0	Geschoord	4.375	0.0	
20	5.000	Geschoord	5.000	0.0	Geschoord	5.000	0.0	
21	4.375	Ongeschoord	4.380*	0.0	Geschoord	4.375	0.0	
22	5.000	Geschoord	5.000	0.0	Geschoord	5.000	0.0	
23	4.375	Ongeschoord	4.380*	0.0	Geschoord	4.375	0.0	
24	5.000	Geschoord	5.000	0.0	Geschoord	5.000	0.0	
25	4.375	Ongeschoord	4.380*	0.0	Geschoord	4.375	0.0	
26	5.000	Geschoord	5.000	0.0	Geschoord	5.000	0.0	
27	4.375	Ongeschoord	4.380*	0.0	Geschoord	4.375	0.0	
28	5.000	Geschoord	5.000	0.0	Geschoord	5.000	0.0	
29	4.375	Ongeschoord	4.380*	0.0	Geschoord	4.375	0.0	
30	5.000	Geschoord	5.000	0.0	Geschoord	5.000	0.0	
31	4.375	Ongeschoord	4.380*	0.0	Geschoord	4.375	0.0	
32	5.000	Geschoord	5.000	0.0	Geschoord	5.000	0.0	
33	4.375	Ongeschoord	4.380*	0.0	Geschoord	4.375	0.0	
34	4.700	Geschoord	4.700	0.0	Geschoord	4.700	0.0	
35	4.375	Ongeschoord	4.380*	0.0	Geschoord	4.375	0.0	
36	5.000	Geschoord	5.000	0.0	Geschoord	5.000	0.0	
37	5.000	Geschoord	5.000	0.0	Geschoord	5.000	0.0	
38	5.000	Geschoord	5.000	0.0	Geschoord	5.000	0.0	
39	5.000	Geschoord	5.000	0.0	Geschoord	5.000	0.0	
40	5.000	Geschoord	5.000*	0.0	Geschoord	5.000	0.0	
41	5.000	Geschoord	5.000*	0.0	Geschoord	5.000	0.0	
42	4.375	Ongeschoord	4.380*	0.0	Geschoord	4.375	0.0	
43	5.000	Geschoord	5.000*	0.0	Geschoord	5.000	0.0	
44	4.375	Ongeschoord	4.380*	0.0	Geschoord	4.375	0.0	
45	4.375	Ongeschoord	4.380*	0.0	Geschoord	4.375	0.0	
46	4.700	Geschoord	4.700	0.0	Geschoord	4.700	0.0	
47	4.375	Ongeschoord	4.380*	0.0	Geschoord	4.375	0.0	
48	5.000	Geschoord	5.000*	0.0	Geschoord	5.000	0.0	
49	4.375	Ongeschoord	4.380*	0.0	Geschoord	4.375	0.0	
50	4.493	Ongeschoord	4.490*	0.0	Geschoord	4.493	0.0	
51	5.000	Geschoord	5.000*	0.0	Geschoord	5.000	0.0	
52	4.375	Ongeschoord	4.380*	0.0	Geschoord	4.375	0.0	
53	5.000	Geschoord	5.000*	0.0	Geschoord	5.000	0.0	
54	4.375	Ongeschoord	4.380*	0.0	Geschoord	4.375	0.0	
55	5.000	Geschoord	5.000*	0.0	Geschoord	5.000	0.0	
56	4.375	Ongeschoord	4.380*	0.0	Geschoord	4.375	0.0	
57	4.724	Ongeschoord	4.720*	0.0	Geschoord	4.724	0.0	
58	5.025	Ongeschoord	5.020*	0.0	Geschoord	5.025	0.0	
59	4.375	Ongeschoord	4.380*	0.0	Geschoord	4.375	0.0	
60	4.700	Geschoord	4.700	0.0	Geschoord	4.700	0.0	
61	4.375	Ongeschoord	4.380*	0.0	Geschoord	4.375	0.0	
62	1.492	Ongeschoord	1.490*	0.0	Geschoord	1.492	0.0	
63	5.026	Ongeschoord	5.020*	0.0	Geschoord	5.026	0.0	
64	1.500	Ongeschoord	1.500*	0.0	Geschoord	1.500	0.0	
65	5.025	Ongeschoord	5.020*	0.0	Geschoord	5.025	0.0	

66	1.000	Ongeschoord	1.000*	0.0	Geschoord	1.000	0.0
67	5.025	Ongeschoord	5.020*	0.0	Geschoord	5.025	0.0
68	0.500	Ongeschoord	0.500*	0.0	Geschoord	0.500	0.0
69	5.025	Ongeschoord	5.020*	0.0	Geschoord	5.025	0.0
70	0.985	Ongeschoord	0.980*	0.0	Geschoord	0.985	0.0

Onderdeel....:

KNIKSTABILITEIT

Staafl	l _{sys} [m]	Classif. y sterke as	l _{knik;y} [m]	Extra		l _{knik;z} [m]	Extra	
				aanp. y [kN]	zwakke as		aanp. z [kN]	zwakke as
71	5.026	Ongeschoord	5.030*	0.0	Geschoord	5.026	0.0	0.0
72	0.477	Ongeschoord	0.480*	0.0	Geschoord	0.477	0.0	0.0
73	5.026	Ongeschoord	5.030*	0.0	Geschoord	5.026	0.0	0.0
74	5.000	Geschoord	5.000*	0.0	Geschoord	5.000	0.0	0.0
75	4.550	Ongeschoord	4.550*	0.0	Geschoord	4.550	0.0	0.0
76	4.375	Ongeschoord	4.380*	0.0	Geschoord	4.375	0.0	0.0
77	4.375	Ongeschoord	4.380*	0.0	Geschoord	4.375	0.0	0.0
78	4.375	Ongeschoord	4.380*	0.0	Geschoord	4.375	0.0	0.0
79	4.375	Ongeschoord	4.380*	0.0	Geschoord	4.375	0.0	0.0
80	4.375	Ongeschoord	4.380*	0.0	Geschoord	4.375	0.0	0.0
81	4.375	Ongeschoord	4.380*	0.0	Geschoord	4.375	0.0	0.0
82	5.000	Geschoord	5.000*	0.0	Geschoord	5.000	0.0	0.0
83	5.000	Geschoord	5.000*	0.0	Geschoord	5.000	0.0	0.0
84	6.502	Geschoord	6.502	0.0	Geschoord	6.502	0.0	0.0
85	6.644	Geschoord	6.644	0.0	Geschoord	6.644	0.0	0.0
86	6.644	Geschoord	6.644	0.0	Geschoord	6.644	0.0	0.0
87	6.644	Geschoord	6.644	0.0	Geschoord	6.644	0.0	0.0
88	6.644	Geschoord	6.644	0.0	Geschoord	6.644	0.0	0.0
89	6.644	Geschoord	6.644	0.0	Geschoord	6.644	0.0	0.0
90	6.644	Geschoord	6.644	0.0	Geschoord	6.644	0.0	0.0
91	6.722	Geschoord	6.722	0.0	Geschoord	6.722	0.0	0.0

* Door gebruiker gedefinieerde kniklengte

KIPSTABILITEIT

Staafl	Plts. aangr.	1 gaffel	Kipsteunafstanden	
			[m]	[m]
1	1.0*h	boven:	4.49	4.493
		onder:		4.493
2	1.0*h	boven:	2.00	2.000
		onder:		2.000
3	1.0*h	boven:	4.70	4.700
		onder:		4.700
4	1.0*h	boven:	4.38	4.375
		onder:		4.375
5	1.0*h	boven:	5.00	5.000
		onder:		5.000
6	1.0*h	boven:	4.38	4.375
		onder:		4.375
7	1.0*h	boven:	5.00	5.000
		onder:		5.000
8	1.0*h	boven:	4.38	4.375
		onder:		4.375
9	1.0*h	boven:	5.00	5.000
		onder:		5.000
10	1.0*h	boven:	4.38	4.375
		onder:		4.375
11	1.0*h	boven:	5.00	5.000
		onder:		5.000
12	1.0*h	boven:	4.38	4.375
		onder:		4.375
13	1.0*h	boven:	5.00	5.000
		onder:		5.000
14	1.0*h	boven:	4.38	4.375
		onder:		4.375
15	1.0*h	boven:	5.00	5.000
		onder:		5.000
16	1.0*h	boven:	4.38	4.375
		onder:		4.375

Onderdeel....:

KIPSTABILITEIT

Staafl	Plts. aangr.	1 gaffel	Kipsteunafstanden	
			[m]	[m]
17	1.0*h	boven:	5.00	5.000
		onder:		5.000
18	1.0*h	boven:	4.38	4.375
		onder:		4.375
19	1.0*h	boven:	4.38	4.375
		onder:		4.375
20	1.0*h	boven:	5.00	5.000
		onder:		5.000

21	1.0*h	boven:	4.38	4.375
		onder:		4.375
22	1.0*h	boven:	5.00	5.000
		onder:		5.000
23	1.0*h	boven:	4.38	4.375
		onder:		4.375
24	1.0*h	boven:	5.00	5.000
		onder:		5.000
25	1.0*h	boven:	4.38	4.375
		onder:		4.375
26	1.0*h	boven:	5.00	5.000
		onder:		5.000
27	1.0*h	boven:	4.38	4.375
		onder:		4.375
28	1.0*h	boven:	5.00	5.000
		onder:		5.000
29	1.0*h	boven:	4.38	4.375
		onder:		4.375
30	1.0*h	boven:	5.00	5.000
		onder:		5.000
31	1.0*h	boven:	4.38	4.375
		onder:		4.375
32	1.0*h	boven:	5.00	5.000
		onder:		5.000
33	1.0*h	boven:	4.38	4.375
		onder:		4.375
34	1.0*h	boven:	4.70	4.700
		onder:		4.700
35	1.0*h	boven:	4.38	4.375
		onder:		4.375
36	1.0*h	boven:	5.00	5.000
		onder:		5.000
37	1.0*h	boven:	5.00	5.000
		onder:		5.000
38	1.0*h	boven:	5.00	5.000
		onder:		5.000
39	1.0*h	boven:	5.00	5.000
		onder:		5.000
40	1.0*h	boven:	5.00	5.000
		onder:		5.000
41	1.0*h	boven:	5.00	5.000
		onder:		5.000
42	1.0*h	boven:	4.38	4.375
		onder:		4.375
43	1.0*h	boven:	5.00	5.000
		onder:		5.000
44	1.0*h	boven:	4.38	4.375
		onder:		4.375
45	1.0*h	boven:	4.38	4.375
		onder:		4.375

Onderdeel....:

KIPSTABILITEIT

Staaft	Plts. aangr.		l gaffel [m]	Kipsteunafstanden [m]
46	1.0*h	boven:	4.70	4.700
		onder:		4.700
47	1.0*h	boven:	4.38	4.375
		onder:		4.375
48	1.0*h	boven:	5.00	5.000
		onder:		5.000
49	1.0*h	boven:	4.38	4.375
		onder:		4.375
50	1.0*h	boven:	4.49	4.493
		onder:		4.493
51	1.0*h	boven:	5.00	5.000
		onder:		5.000
52	1.0*h	boven:	4.38	4.375
		onder:		4.375
53	1.0*h	boven:	5.00	5.000
		onder:		5.000
54	1.0*h	boven:	4.38	4.375
		onder:		4.375
55	1.0*h	boven:	5.00	5.000
		onder:		5.000
56	1.0*h	boven:	4.38	4.375
		onder:		4.375
57	1.0*h	boven:	4.72	4.724
		onder:		4.724
58	1.0*h	boven:	5.02	5.025
		onder:		5.025

59	1.0*h	boven:	4.38	4.375
		onder:		4.375
60	1.0*h	boven:	4.70	4.700
		onder:		4.700
61	1.0*h	boven:	4.38	4.375
		onder:		4.375
62	1.0*h	boven:	1.49	1.492
		onder:		1.492
63	1.0*h	boven:	5.03	5.026
		onder:		5.026
64	1.0*h	boven:	1.50	1.500
		onder:		1.500
65	1.0*h	boven:	5.02	5.025
		onder:		5.025
66	1.0*h	boven:	1.00	1.000
		onder:		1.000
67	1.0*h	boven:	5.02	5.025
		onder:		5.025
68	1.0*h	boven:	0.50	0.500
		onder:		0.500
69	1.0*h	boven:	5.02	5.025
		onder:		5.025
70	1.0*h	boven:	0.98	0.985
		onder:		0.985
71	1.0*h	boven:	5.03	5.026
		onder:		5.026
72	1.0*h	boven:	0.48	0.477
		onder:		0.477
73	1.0*h	boven:	5.03	5.026
		onder:		5.026
74	1.0*h	boven:	5.00	5.000
		onder:		5.000
75	1.0*h	boven:	4.55	4.550
		onder:		4.550

Onderdeel....:

KIPSTABILITEIT

Staafl	P/M	BC	Sit	Kl	Plaats	Norm	Artikel	Formule	Hoogste toetsing	Opm.
nr.									U.C. [N/mm ²]	
76	1.0*h	boven:	4.38	4.375						
		onder:		4.375						
77	1.0*h	boven:	4.38	4.375						
		onder:		4.375						
78	1.0*h	boven:	4.38	4.375						
		onder:		4.375						
79	1.0*h	boven:	4.38	4.375						
		onder:		4.375						
80	1.0*h	boven:	4.38	4.375						
		onder:		4.375						
81	1.0*h	boven:	4.38	4.375						
		onder:		4.375						
82	1.0*h	boven:	5.00	5.000						
		onder:		5.000						
83	1.0*h	boven:	5.00	5.000						
		onder:		5.000						
84	1.0*h	boven:	6.50	6.502						
		onder:		6.502						
85	1.0*h	boven:	6.64	6.644						
		onder:		6.644						
86	1.0*h	boven:	6.64	6.644						
		onder:		6.644						
87	1.0*h	boven:	6.64	6.644						
		onder:		6.644						
88	1.0*h	boven:	6.64	6.644						
		onder:		6.644						
89	1.0*h	boven:	6.64	6.644						
		onder:		6.644						
90	1.0*h	boven:	6.64	6.644						
		onder:		6.644						
91	1.0*h	boven:	6.72	6.722						
		onder:		6.722						

TOETSING SPANNINGEN

Staafl	P/M	BC	Sit	Kl	Plaats	Norm	Artikel	Formule	Hoogste toetsing	Opm.	
nr.									U.C. [N/mm ²]		
1	1	43	1	1	Staafl	EN3-1-1	6.3.3	(6.62)	0.157	37	47
2	2	43	1	1	Staafl	EN3-1-1	6.3.1.1	T(6.46)	0.106	38	47,8,4
3	3	39	1	2	Staafl	EN3-1-1	6.3.1.1	(6.46z)	0.220	52	
4	2	51	1	1	Staafl	EN3-1-1	6.3.3	(6.62)	0.038	13	47
5	3	39	1	2	Staafl	EN3-1-1	6.3.1.1	(6.46z)	0.426	100	
6	2	51	1	1	Staafl	EN3-1-1	6.3.3	(6.62)	0.170	60	47

7	3	33	1	2	Staaaf	EN3-1-1	6.3.1.1	(6.46z)	0.080	19	
8	2	51	1	1	Staaaf	EN3-1-1	6.3.3	(6.62)	0.073	26	47
9	3	21	1	2	Staaaf	EN3-1-1	6.3.1.1	(6.46z)	0.161	38	
10	2	43	1	1	Staaaf	EN3-1-1	6.3.3	(6.62)	0.165	58	47
11	3	47	1	2	Staaaf	EN3-1-1	6.3.1.1	(6.46z)	0.494	116	
12	2	43	1	1	Staaaf	EN3-1-1	6.3.3	(6.62)	0.057	20	47
13	3	47	1	2	Staaaf	EN3-1-1	6.3.1.1	(6.46z)	0.342	80	
14	2	43	1	1	Staaaf	EN3-1-1	6.3.3	(6.62)	0.034	12	47
15	3	47	1	2	Staaaf	EN3-1-1	6.3.1.1	(6.46z)	0.262	62	
16	2	43	1	1	Staaaf	EN3-1-1	6.3.3	(6.62)	0.038	14	47
17	3	47	1	2	Staaaf	EN3-1-1	6.3.1.1	(6.46z)	0.241	57	
18	1	31	1	1	Staaaf	EN3-1-1	6.3.2	(6.54)	0.157	37	
19	2	51	1	1	Staaaf	EN3-1-1	6.3.3	(6.62)	0.035	13	47
20	3	23	1	2	Staaaf	EN3-1-1	6.3.1.1	(6.46z)	0.101	24	
21	2	51	1	4	Staaaf	EN3-1-1	6.3.3	(6.62)	0.134	32	47,129
22	3	12	1	2	Staaaf	EN3-1-1	6.3.3	(6.61)	0.075	18	

Onderdeel....:

TOETSING SPANNINGEN

Staaaf P/M nr.	BC	Sit	Kl	Plaats	Norm	Artikel	Formule	Hoogste toetsing U.C. [N/mm ²]	Opm.
23	2	43	1	4	Staaaf	EN3-1-1	6.3.3 (6.62)	0.036	9 47,129
24	3	4	1	1	Staaaf	EN3-1-1	6.3.3 (6.61)	0.066	16
25	2	43	1	4	Staaaf	EN3-1-1	6.3.3 (6.62)	0.135	32 47,129
26	3	31	1	2	Staaaf	EN3-1-1	6.3.1.1 (6.46z)	0.103	24
27	2	45	1	4	Staaaf	EN3-1-1	6.3.3 (6.62)	0.036	9 47,129
28	3	31	1	2	Staaaf	EN3-1-1	6.3.1.1 (6.46z)	0.137	32
29	2	43	1	1	Staaaf	EN3-1-1	6.3.3 (6.62)	0.036	13 47
30	3	31	1	2	Staaaf	EN3-1-1	6.3.1.1 (6.46z)	0.131	31
31	2	43	1	1	Staaaf	EN3-1-1	6.3.3 (6.62)	0.041	15 47
32	3	31	1	2	Staaaf	EN3-1-1	6.3.1.1 (6.46z)	0.105	25
33	1	31	1	1	Begin	EN3-1-1	6.2.10 (6.45+6.31y)	0.157	37
34	3	43	1	2	Staaaf	EN3-1-1	6.3.1.1 (6.46z)	0.074	17
35	2	51	1	4	Staaaf	EN3-1-1	6.3.3 (6.62)	0.040	9 47,129
36	3	43	1	2	Staaaf	EN3-1-1	6.3.1.1 (6.46z)	0.079	19
37	3	12	1	1	Staaaf	EN3-1-1	6.3.3 (6.61)	0.050	12
38	3	10	1	1	Staaaf	EN3-1-1	6.3.3 (6.61)	0.053	13
39	3	31	1	2	Staaaf	EN3-1-1	6.3.1.1 (6.46z)	0.077	18
40	3	18	1	1	Staaaf	EN3-1-1	6.3.3 (6.61)	0.074	17
41	3	53	1	2	Staaaf	EN3-1-1	6.3.3 (6.61)	0.076	18
42	2	47	1	4	Staaaf	EN3-1-1	6.3.3 (6.62)	0.042	10 47,129
43	3	51	1	2	Staaaf	EN3-1-1	6.3.1.1 (6.46z)	0.082	19
44	1	51	1	1	Staaaf	EN3-1-1	6.3.3 (6.62)	0.145	34 47
45	1	43	1	1	Staaaf	EN3-1-1	6.3.3 (6.62)	0.149	35 47
46	3	23	1	2	Staaaf	EN3-1-1	6.3.1.1 (6.46z)	0.090	21
47	2	39	1	4	Staaaf	EN3-1-1	6.3.3 (6.62)	0.052	12 47,129
48	3	43	1	1	Staaaf	EN3-1-1	6.3.3 (6.61)	0.063	15
49	2	51	1	4	Staaaf	EN3-1-1	6.3.3 (6.62)	0.129	31 47,129
50	2	47	1	4	Staaaf	EN3-1-1	6.3.3 (6.62)	0.041	10 47,129
51	3	53	1	2	Staaaf	EN3-1-1	6.3.3 (6.61)	0.077	18
52	2	47	1	4	Staaaf	EN3-1-1	6.3.3 (6.62)	0.046	11 47,129
53	3	35	1	2	Staaaf	EN3-1-1	6.3.1.1 (6.46z)	0.097	23
54	1	51	1	1	Staaaf	EN3-1-1	6.3.3 (6.62)	0.152	36 47
55	3	43	1	1	Staaaf	EN3-1-1	6.3.3 (6.61)	0.048	11
56	2	43	1	4	Staaaf	EN3-1-1	6.3.3 (6.62)	0.042	10 47,129
57	1	51	1	1	Staaaf	EN3-1-1	6.3.3 (6.62)	0.278	65 47
58	1	45	1	1	Staaaf	EN3-1-1	6.3.3 (6.62)	0.410	96 46,47
59	1	23	1	1	Staaaf	EN3-1-1	6.3.2 (6.54)	0.152	36
60	3	23	1	2	Staaaf	EN3-1-1	6.3.1.1 (6.46z)	0.095	22
61	1	23	1	1	Begin	EN3-1-1	6.2.10 (6.45+6.31y)	0.152	36
62	2	51	1	1	Staaaf	EN3-1-1	6.3.1.1 T(6.46)	0.077	27 47,8,4
63	1	51	1	1	Staaaf	EN3-1-1	6.3.3 (6.62)	0.615	145 46,47
64	2	47	1	1	Staaaf	EN3-1-1	6.3.1.1 T(6.46)	0.058	21 47,8,4
65	1	45	1	1	Staaaf	EN3-1-1	6.3.3 (6.62)	0.346	81 47
66	2	47	1	1	Staaaf	EN3-1-1	6.3.1.1 T(6.46)	0.028	10 47,8,4
67	1	43	1	1	Staaaf	EN3-1-1	6.3.3 (6.62)	0.309	73 47
68	2	47	1	4	Staaaf	EN3-1-1	6.3.3 (6.61)	0.016	4 47,129,8,4
69	1	43	1	1	Staaaf	EN3-1-1	6.3.3 (6.62)	0.295	69 47
70	2	22	1	1	Staaaf	EN3-1-1	6.3.1.1 T(6.46)	0.094	34 8,4
71	1	51	1	1	Staaaf	EN3-1-1	6.3.3 (6.62)	0.526	124 47
72	2	51	1	1	Einde	EN3-1-1	6.2.1(6) N+D	0.031	11 47,8,4
73	1	51	1	1	Staaaf	EN3-1-1	6.3.3 (6.62)	0.369	87 47
74	3	53	1	1	Staaaf	EN3-1-1	6.3.3 (6.61)	0.069	16
75	2	47	1	4	Staaaf	EN3-1-1	6.3.3 (6.62)	0.045	11 47,129
76	2	47	1	4	Staaaf	EN3-1-1	6.3.3 (6.62)	0.036	9 47,129

Onderdeel....:

TOETSING SPANNINGEN

Staaflnr.	P/M	BC	Sit	Kl	Plaats	Norm	Artikel	Formule	Hoogste toetsing U.C. [N/mm ²]	Opm.
77	2	51	1	4	Staafl	EN3-1-1	6.3.3	(6.62)	0.128 30	47,129
78	2	43	1	4	Staafl	EN3-1-1	6.3.3	(6.62)	0.126 30	47,129
79	2	43	1	4	Staafl	EN3-1-1	6.3.3	(6.62)	0.127 30	47,129
80	2	45	1	4	Staafl	EN3-1-1	6.3.3	(6.62)	0.038 9	47,129
81	2	43	1	4	Staafl	EN3-1-1	6.3.3	(6.62)	0.040 9	47,129
82	3	47	1	1	Staafl	EN3-1-1	6.3.3	(6.61)	0.037 9	
83	3	47	1	1	Staafl	EN3-1-1	6.3.3	(6.61)	0.051 12	
84	4	48	1	1	Staafl	EN3-1-1	6.3.3	(6.61)	0.785 184	47
85	4	47	1	1	Staafl	EN3-1-1	6.3.3	(6.61)	0.779 183	47
86	4	47	1	1	Staafl	EN3-1-1	6.3.3	(6.61)	0.713 168	47
87	4	47	1	1	Staafl	EN3-1-1	6.3.3	(6.61)	0.756 178	47
88	4	39	1	1	Staafl	EN3-1-1	6.3.3	(6.61)	0.785 184	47
89	4	39	1	1	Staafl	EN3-1-1	6.3.3	(6.61)	0.726 171	47
90	4	39	1	1	Staafl	EN3-1-1	6.3.3	(6.61)	0.791 186	47
91	4	40	1	1	Staafl	EN3-1-1	6.3.3	(6.61)	0.806 189	47

Opmerkingen:

- [4] Controle gedrukte T-rand houdt geen rekening met 2e-orde-wringing.
- [8] Controle van de gedrukte rand is toegepast (zonder buiging!).
- [46] T.b.v. kip is een equivalente Q-last berekend.
- [47] Bij verlopende normaalkracht wordt de grootste drukkracht genomen.
- [129] Bij berekening van klasse 4 profielen is gebruik gemaakt van de spanningsreductiemethode.

TOETSING DOORBUIGING

Staaflnr.	Soort	Mtg	Lengte [m]	Overst I J	Zeeg [mm]	u _{tot} [mm]	BC	Sit	u [mm]	Toelaatbaar [mm]	*1
3	Vloer	db	4.70	N N	0.0	-0.8	72	1 Eind	-0.8	±18.8	0.004
		ss					74	1 Bijk	0.2	±28.2	2*0.003
5	Vloer	db	5.00	N N	0.0	-1.1	97	1 Eind	-1.1	±20.0	0.004
		ss					88	1 Bijk	0.7	±30.0	2*0.003
7	Vloer	db	5.00	N N	0.0	-1.1	79	1 Eind	-1.1	±20.0	0.004
		ss					79	1 Bijk	-0.7	±30.0	2*0.003
9	Vloer	db	5.00	N N	0.0	-1.1	72	1 Eind	-1.1	±20.0	0.004
		ss					77	1 Bijk	-0.7	±30.0	2*0.003
11	Vloer	db	5.00	N N	0.0	-1.1	71	1 Eind	-1.1	±20.0	0.004
		ss					96	1 Bijk	0.7	±30.0	2*0.003
13	Vloer	db	5.00	N N	0.0	-1.1	71	1 Eind	-1.1	±20.0	0.004
		ss					94	1 Bijk	-0.0	±30.0	2*0.003
15	Vloer	db	5.00	N N	0.0	-1.1	75	1 Eind	-1.1	±20.0	0.004
		ss					86	1 Bijk	-0.0	±30.0	2*0.003
17	Vloer	db	5.00	N N	0.0	-1.1	78	1 Eind	-1.1	±20.0	0.004
		ss					82	1 Bijk	0.2	±30.0	2*0.003
20	Vloer	db	5.00	N N	0.0	-1.1	79	1 Eind	-1.1	±20.0	0.004
		ss					88	1 Bijk	0.5	±30.0	2*0.003
22	Vloer	db	5.00	N N	0.0	-1.1	81	1 Eind	-1.1	±20.0	0.004
		ss					79	1 Bijk	-0.5	±30.0	2*0.003
24	Vloer	db	5.00	N N	0.0	-1.1	72	1 Eind	-1.1	±20.0	0.004
		ss					77	1 Bijk	-0.5	±30.0	2*0.003
26	Vloer	db	5.00	N N	0.0	-1.1	90	1 Eind	-1.1	±20.0	0.004
		ss					96	1 Bijk	0.5	±30.0	2*0.003
28	Vloer	db	5.00	N N	0.0	-1.1	75	1 Eind	-1.1	±20.0	0.004
		ss					94	1 Bijk	-0.0	±30.0	2*0.003
30	Vloer	db	5.00	N N	0.0	-1.1	74	1 Eind	-1.1	±20.0	0.004
		ss					86	1 Bijk	-0.0	±30.0	2*0.003
32	Vloer	db	5.00	N N	0.0	-1.1	71	1 Eind	-1.1	±20.0	0.004
		ss					82	1 Bijk	0.1	±30.0	2*0.003
34	Vloer	db	4.70	N N	0.0	-0.8	73	1 Eind	-0.8	±18.8	0.004
		ss					74	1 Bijk	-0.1	±28.2	2*0.003
36	Vloer	db	5.00	N N	0.0	-1.1	85	1 Eind	-1.1	±20.0	0.004
		ss					88	1 Bijk	0.4	±30.0	2*0.003

Onderdeel....:

TOETSING DOORBUIGING

Staaflnr.	Soort	Mtg	Lengte [m]	Overst I J	Zeeg [mm]	u _{tot} [mm]	BC	Sit	u [mm]	Toelaatbaar [mm]	*1
37	Vloer	db	5.00	N N	0.0	-1.1	87	1 Eind	-1.1	±20.0	0.004
		ss					79	1 Bijk	-0.4	±30.0	2*0.003
38	Vloer	db	5.00	N N	0.0	-1.1	71	1 Eind	-1.1	±20.0	0.004
		ss					77	1 Bijk	-0.3	±30.0	2*0.003
39	Vloer	db	5.00	N N	0.0	-1.1	74	1 Eind	-1.1	±20.0	0.004
		ss					96	1 Bijk	0.4	±30.0	2*0.003
40	Vloer	db	5.00	N N	0.0	-1.1	73	1 Eind	-1.1	±20.0	0.004
		ss					96	1 Bijk	-0.0	±30.0	2*0.003
41	Vloer	db	5.00	N N	0.0	-1.1	77	1 Eind	-1.1	±20.0	0.004
		ss					85	1 Bijk	-0.0	±30.0	2*0.003
43	Vloer	db	5.00	N N	0.0	-1.1	71	1 Eind	-1.1	±20.0	0.004
		ss					82	1 Bijk	-0.1	±30.0	2*0.003

46	Vloer	db	4.70	N	N	0.0	-0.8	71	1	Eind	-0.8	±18.8	0.004
		ss						74	1	Bijk	-0.1	±28.2	2*0.003
48	Vloer	db	5.00	N	N	0.0	-1.1	81	1	Eind	-1.1	±20.0	0.004
		ss						88	1	Bijk	0.2	±30.0	2*0.003
51	Vloer	db	5.00	N	N	0.0	-1.1	78	1	Eind	-1.1	±20.0	0.004
		ss						85	1	Bijk	-0.0	±30.0	2*0.003
53	Vloer	db	5.00	N	N	0.0	-1.1	78	1	Eind	-1.1	±20.0	0.004
		ss						82	1	Bijk	-0.0	±30.0	2*0.003
55	Vloer	db	5.00	N	N	0.0	-1.1	102	1	Eind	-1.1	±20.0	0.004
		ss						79	1	Bijk	-0.2	±30.0	2*0.003
57	Dak	db	4.72	N	N	0.0	-2.2	92	1	Eind	-2.2	-18.9	0.004
		db						92	1	Bijk	-1.2	-18.9	0.004
58	Dak	db	5.02	N	N	0.0	-2.7	94	1	Eind	-2.7	-20.1	0.004
		db						94	1	Bijk	-1.9	-20.1	0.004
60	Vloer	db	4.70	N	N	0.0	-0.8	71	1	Eind	-0.8	±18.8	0.004
		ss						74	1	Bijk	-0.1	±28.2	2*0.003
63	Dak	db	5.03	N	N	0.0	-2.5	102	1	Eind	-2.5	-20.1	0.004
		db						102	1	Bijk	-1.7	-20.1	0.004
65	Dak	db	5.02	N	N	0.0	-2.0	100	1	Eind	-2.0	-20.1	0.004
		db						100	1	Bijk	-1.2	-20.1	0.004
67	Dak	db	5.02	N	N	0.0	-1.8	98	1	Eind	-1.8	-20.1	0.004
		db						98	1	Bijk	-1.2	-20.1	0.004
69	Dak	db	5.02	N	N	0.0	-2.9	100	1	Eind	-2.9	-20.1	0.004
		db						100	1	Bijk	-1.6	-20.1	0.004
71	Dak	db	5.03	N	N	0.0	-1.8	100	1	Eind	-1.8	-20.1	0.004
		db						100	1	Bijk	-1.0	-20.1	0.004
73	Dak	db	5.03	N	N	0.0	-1.9	90	1	Eind	-1.9	-20.1	0.004
		db						90	1	Bijk	-1.2	-20.1	0.004
74	Vloer	db	5.00	N	N	0.0	-1.1	73	1	Eind	-1.1	±20.0	0.004
		ss						96	1	Bijk	-0.0	±30.0	2*0.003
82	Vloer	db	5.00	N	N	0.0	-1.1	71	1	Eind	-1.1	±20.0	0.004
		ss						77	1	Bijk	-0.2	±30.0	2*0.003
83	Vloer	db	5.00	N	N	0.0	-1.1	76	1	Eind	-1.1	±20.0	0.004
		ss						96	1	Bijk	0.2	±30.0	2*0.003

TOETSING HORIZONTALE VERPLAATSING

Staaft	BC	Sit	Lengte [m]	u_{eind} [mm]	Toelaatbaar [mm]	Maatgevend [h/]
1	88	1	4.493	-2.6	15.0	300 scheefstand
2	96	1	2.000	2.9	6.7	300 scheefstand
4	79	1	4.375	3.6	14.6	300 scheefstand
6	79	1	4.375	3.0	14.6	300 scheefstand
8	96	1	4.375	3.0	14.6	300 scheefstand
10	71	1	4.375	-2.9	14.6	300 scheefstand
12	71	1	4.375	-3.5	14.6	300 scheefstand
14	71	1	4.375	-3.9	14.6	300 scheefstand
16	71	1	4.375	-4.2	14.6	300 scheefstand
18	71	1	4.375	-4.5	14.6	300 scheefstand

Onderdeel....:

TOETSING HORIZONTALE VERPLAATSING

Staaft	BC	Sit	Lengte [m]	u_{eind} [mm]	Toelaatbaar [mm]	Maatgevend [h/]
19	97	1	4.375	2.3	14.6	300 scheefstand
21	97	1	4.375	2.3	14.6	300 scheefstand
23	96	1	4.375	2.3	14.6	300 scheefstand
25	89	1	4.375	-2.3	14.6	300 scheefstand
27	88	1	4.375	-2.3	14.6	300 scheefstand
29	88	1	4.375	-2.5	14.6	300 scheefstand
31	88	1	4.375	-2.6	14.6	300 scheefstand
33	88	1	4.375	-2.6	14.6	300 scheefstand
35	71	1	4.375	-2.0	14.6	300 scheefstand
42	79	1	4.375	2.1	14.6	300 scheefstand
44	79	1	4.375	2.1	14.6	300 scheefstand
45	88	1	4.375	-2.0	14.6	300 scheefstand
47	88	1	4.375	-2.5	14.6	300 scheefstand
49	88	1	4.375	-2.4	14.6	300 scheefstand
50	96	1	4.493	2.5	15.0	300 scheefstand
52	96	1	4.375	2.6	14.6	300 scheefstand
54	96	1	4.375	2.8	14.6	300 scheefstand
56	88	1	4.375	-2.3	14.6	300 scheefstand
59	97	1	4.375	2.3	14.6	300 scheefstand
61	79	1	4.375	3.9	14.6	300 scheefstand
62	96	1	1.492	1.9	5.0	300 scheefstand
64	71	1	1.500	-1.9	5.0	300 scheefstand
66	71	1	1.000	-1.1	3.3	300 scheefstand
68	71	1	0.500	-0.5	1.7	300 scheefstand
70	89	1	0.985	-1.4	3.3	300 scheefstand
72	79	1	0.477	0.5	1.6	300 scheefstand

75	96	1	4.550	2.4	15.2	300	scheefstand
76	79	1	4.375	2.1	14.6	300	scheefstand
77	71	1	4.375	-2.0	14.6	300	scheefstand
78	79	1	4.375	2.0	14.6	300	scheefstand
79	96	1	4.375	2.3	14.6	300	scheefstand
80	79	1	4.375	2.1	14.6	300	scheefstand
81	88	1	4.375	-2.0	14.6	300	scheefstand

TOETSING HOR. VERPLAATSING GLOBAAL

Er is een maximale horizontale verplaatsing van -0.0123 [m] gevonden bij knoop 6 en combinatie 96; belastingsituatie 1 (combinatietype 2). Bij een hoogte van 19.675 [m] levert dit $h / 1595$ (toel.: $h / 300$).

A - 3 Facade K

Technosoft Raamwerken release 6.79a

17 jan 2024

Project.....: MM20152
 Dimensies....: kN;m;rad (tenzij anders aangegeven)
 Bestand.....: K:\Projecten\MM20152\10 Constructeur\03 DO - Definitief
 Ontwerp\reacties\facade as K.rww

Belastingbreedte.: 2.350
 Rekenmodel.....: 1e-orde-elastisch.
 Theorie voor de bepaling van de krachtsverdeling:
 Geometrisch lineair.
 Fysisch lineair.

Gunstige werking van de permanente belasting wordt automatisch verwerkt.

Toegepaste normen volgens Eurocode met Nederlandse NB

Belastingen	NEN-EN 1990:2002	C2:2010,A1:2019	NB:2019(nl)
	NEN-EN 1991-1-1:2002	C1/C11:2019	NB:2019(nl)
	NEN-EN 1991-1-4:2005	C2:2011	NB:2011(nl)
Staal	NEN-EN 1993-1-1:2006	C2:2011,A1:2016	NB:2016(nl)

GEOMETRIE

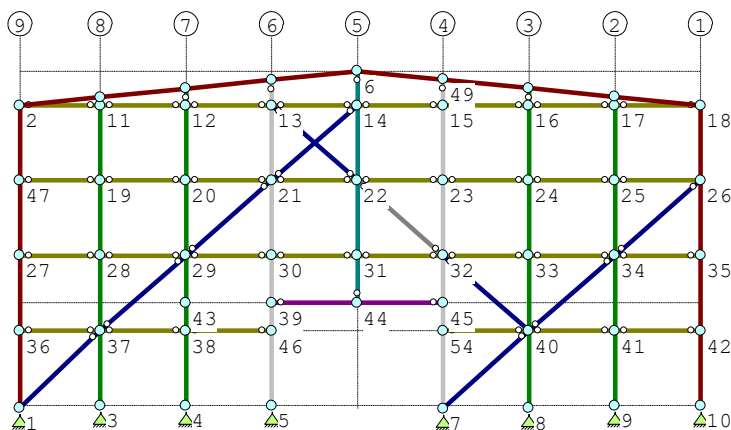

STRAMIENLIJNEN

Nr.	Naam	X	Z-min	Z-max
1	8	4.700	-0.175	19.500
2	7	9.700	-0.175	19.500
3	6	14.700	-0.175	19.500
4	5	19.700	-0.175	19.500
5	4	24.700	-0.175	19.500
6	3	29.700	-0.175	19.500
7	2	34.700	-0.175	19.500
8	1	39.700	-0.175	19.500
9	9	0.000	-0.175	19.500

NIVEAUS

Nr.	Z	X-min	X-max
1	0.000	0.000	39.700
2	4.375	0.000	39.700
3	8.750	0.000	39.700
4	13.125	0.000	39.700
5	17.500	0.000	39.700
6	19.500	0.000	39.700
7	6.000	0.000	39.700

Onderdeel.....:

MATERIALEN

Mt	Kwaliteit	E-modulus[N/mm2]	S.G.	Pois.	Uitz. coëff
1	S235	210000	78.5	0.30	1.2000e-05
2	S355	210000	78.5	0.30	1.2000e-05

PROFIELEN [mm]

Prof.	Omschrijving	Materiaal	Oppervlak	Traagheid	Vormf.
1	HEA160	1:S235	3.8800e+03	1.6730e+07	0.00
2	IPE500	2:S355	1.1550e+04	4.8200e+08	0.00
3	K150/100/4CF	1:S235	1.8948e+03	5.9460e+06	0.00
4	K150/150/SCF	1:S235	2.8356e+03	9.8212e+06	0.00
5	K300/200/10CF(90)	1:S235	9.2566e+03	6.0577e+07	0.00

6 IPE300	2:S355	5.3800e+03	8.3560e+07	0.00
7 IPE600	1:S235	1.5600e+04	9.2080e+08	0.00
8 K150/150/8CF	1:S235	4.3243e+03	1.4118e+07	0.00

PROFIELEN vervolg [mm]

Prof.	Staaftype	Breedte	Hoogte	e	Type	b1	h1	b2	h2
1	0:Normaal	160	152	76.0					
2	0:Normaal	200	500	250.0					
3	0:Normaal	100	150	75.0					
4	0:Normaal	150	150	75.0					
5	0:Normaal	200	300	100.0					
6	0:Normaal	150	300	150.0					
7	0:Normaal	220	600	300.0					
8	0:Normaal	150	150	75.0					

PROFIELVORMEN [mm]

1 HEA160



2 IPE500



3 K150/100/4CF



4 K150/150/5CF



5 K300/200/10CF (90)



6 IPE300



7 IPE600



8 K150/150/8CF



Onderdeel.....:

KNOPEN

Knoop	X	Z	Knoop	X	Z
1	0.000	-0.118	6	19.700	19.500
2	0.000	17.500	7	24.700	-0.175
3	4.700	0.000	8	29.700	-0.118
4	9.700	0.000	9	34.700	0.000
5	14.700	0.000	10	39.700	0.000
11	4.700	17.500	16	29.700	17.500
12	9.700	17.500	17	34.700	17.500
13	14.700	17.500	18	39.700	17.500
14	19.700	17.500	19	4.700	13.125
15	24.700	17.500	20	9.700	13.125
21	14.700	13.125	26	39.700	13.125
22	19.700	13.125	27	0.000	8.750
23	24.700	13.125	28	4.700	8.750
24	29.700	13.125	29	9.700	8.750
25	34.700	13.125	30	14.700	8.750
31	19.700	8.750	36	0.000	4.375
32	24.700	8.750	37	4.700	4.375
33	29.700	8.750	38	9.700	4.375
34	34.700	8.750	39	14.700	6.000
35	39.700	8.750	40	29.700	4.375
41	34.700	4.375	46	14.700	4.375
42	39.700	4.375	47	0.000	13.125
43	9.700	6.000	48	14.700	18.992
44	19.700	6.000	49	24.700	19.000

45	24.700	6.000	50	29.700	18.500
51	34.700	18.000			
52	9.700	18.485			
53	4.700	17.977			
54	24.700	4.375			

STAVEN

St.	ki	kj	Profiel	Aansl.i	Aansl.j	Lengte	Opm.
1	1	36	1:HEA160	NDM	NDM	4.493	
2	6	14	6:IPE300	ND-	NDM	2.000	
3	2	11	3:K150/100/4CF	ND-	ND-	4.700	
4	11	19	2:IPE500	NDM	NDM	4.375	
5	11	12	3:K150/100/4CF	ND-	ND-	5.000	
6	12	20	2:IPE500	NDM	NDM	4.375	
7	12	13	3:K150/100/4CF	ND-	ND-	5.000	
8	13	21	7:IPE600	NDM	NDM	4.375	
9	13	14	3:K150/100/4CF	ND-	ND-	5.000	
10	14	22	6:IPE300	NDM	NDM	4.375	
11	14	15	3:K150/100/4CF	ND-	ND-	5.000	
12	15	23	7:IPE600	NDM	NDM	4.375	
13	15	16	3:K150/100/4CF	ND-	ND-	5.000	
14	16	24	2:IPE500	NDM	NDM	4.375	
15	16	17	3:K150/100/4CF	ND-	ND-	5.000	
16	17	25	2:IPE500	NDM	NDM	4.375	
17	17	18	3:K150/100/4CF	ND-	ND-	5.000	
18	18	26	1:HEA160	NDM	NDM	4.375	
19	19	28	2:IPE500	NDM	NDM	4.375	
20	19	20	3:K150/100/4CF	ND-	ND-	5.000	
21	20	29	2:IPE500	NDM	NDM	4.375	
22	20	21	3:K150/100/4CF	ND-	ND-	5.000	
23	21	30	7:IPE600	NDM	NDM	4.375	
24	21	22	3:K150/100/4CF	ND-	ND-	5.000	
25	22	31	6:IPE300	NDM	NDM	4.375	

Onderdeel.....:

STAVEN

St.	ki	kj	Profiel	Aansl.i	Aansl.j	Lengte	Opm.
26	22	23	3:K150/100/4CF	ND-	ND-	5.000	
27	23	32	7:IPE600	NDM	NDM	4.375	
28	23	24	3:K150/100/4CF	ND-	ND-	5.000	
29	24	33	2:IPE500	NDM	NDM	4.375	
30	24	25	3:K150/100/4CF	ND-	ND-	5.000	
31	25	34	2:IPE500	NDM	NDM	4.375	
32	25	26	3:K150/100/4CF	ND-	NDM	5.000	
33	26	35	1:HEA160	NDM	NDM	4.375	
34	27	28	3:K150/100/4CF	ND-	ND-	4.700	
35	28	37	2:IPE500	NDM	NDM	4.375	
36	28	29	3:K150/100/4CF	ND-	ND-	5.000	
37	29	43	2:IPE500	NDM	NDM	2.750	
38	29	30	3:K150/100/4CF	ND-	ND-	5.000	
39	30	39	7:IPE600	NDM	NDM	2.750	
40	30	31	3:K150/100/4CF	ND-	ND-	5.000	
41	31	44	6:IPE300	NDM	ND-	2.750	
42	31	32	3:K150/100/4CF	ND-	ND-	5.000	
43	32	45	7:IPE600	NDM	NDM	2.750	
44	32	33	3:K150/100/4CF	ND-	ND-	5.000	
45	33	34	3:K150/100/4CF	ND-	ND-	5.000	
46	34	41	2:IPE500	NDM	NDM	4.375	
47	34	35	3:K150/100/4CF	ND-	ND-	5.000	
48	35	42	1:HEA160	NDM	NDM	4.375	
49	36	27	1:HEA160	NDM	NDM	4.375	
50	36	37	3:K150/100/4CF	ND-	ND-	4.700	
51	37	3	2:IPE500	NDM	NDM	4.375	
52	37	38	3:K150/100/4CF	ND-	ND-	5.000	
53	38	4	2:IPE500	NDM	NDM	4.375	
54	40	8	2:IPE500	NDM	NDM	4.493	
55	40	41	3:K150/100/4CF	ND-	ND-	5.000	
56	41	9	2:IPE500	NDM	NDM	4.375	
57	41	42	3:K150/100/4CF	ND-	ND-	5.000	
58	42	10	1:HEA160	NDM	NDM	4.375	
59	43	38	2:IPE500	NDM	NDM	1.625	
60	44	45	5:K300/200/10CF (90)	NDM	ND-	5.000	
61	39	46	7:IPE600	NDM	NDM	1.625	
62	38	46	3:K150/100/4CF	ND-	ND-	5.000	
63	46	5	7:IPE600	NDM	NDM	4.375	
64	2	53	1:HEA160	NDM	NDM	4.724	

65	6	49	1:HEA160	NDM	NDM	5.025
66	27	47	1:HEA160	NDM	NDM	4.375
67	47	19	3:K150/100/4CF	ND-	ND-	4.700
68	47	2	1:HEA160	NDM	NDM	4.375
69	39	44	5:K300/200/10CF(90)	ND-	NDM	5.000
70	48	13	7:IPE600	ND-	NDM	1.492
71	48	6	1:HEA160	NDM	NDM	5.026
72	49	15	7:IPE600	ND-	NDM	1.500
73	49	50	1:HEA160	NDM	NDM	5.025
74	50	16	2:IPE500	ND-	NDM	1.000
75	50	51	1:HEA160	NDM	NDM	5.025
76	51	17	2:IPE500	ND-	NDM	0.500
77	51	18	1:HEA160	NDM	NDM	5.025
78	52	12	2:IPE500	ND-	NDM	0.985
79	52	48	1:HEA160	NDM	NDM	5.026
80	53	11	2:IPE500	ND-	NDM	0.477

Onderdeel.....:

STAVEN

St.	ki	kj	Profiel	Aansl.i	Aansl.j	Lengte	Opm.
81	53	52	1:HEA160	NDM	NDM	5.026	
82	45	54	7:IPE600	NDM	NDM	1.625	
83	54	40	3:K150/100/4CF	ND-	ND-	5.000	
84	54	7	7:IPE600	NDM	NDM	4.550	
85	33	40	2:IPE500	NDM	NDM	4.375	
86	14	21	4:K150/150/5CF	ND-	ND-	6.644	
87	21	29	4:K150/150/5CF	ND-	ND-	6.644	
88	29	37	4:K150/150/5CF	ND-	ND-	6.644	
89	37	1	4:K150/150/5CF	ND-	NDM	6.502	
90	13	22	4:K150/150/5CF	ND-	ND-	6.644	
91	22	32	8:K150/150/8CF	ND-	ND-	6.644	
92	32	40	4:K150/150/5CF	ND-	NDM	6.644	
93	40	7	4:K150/150/5CF	ND-	NDM	6.760	
94	34	40	4:K150/150/5CF	ND-	ND-	6.644	
95	26	34	4:K150/150/5CF	ND-	ND-	6.644	

VASTE STEUNPUNTEN

Nr.	knoop	Kode	XZR	l=vast	0=vrij	Hoek
1	1	110				0.00
2	3	110				0.00
3	4	110				0.00
4	5	110				0.00
5	7	110				0.00
6	8	110				0.00
7	9	110				0.00
8	10	110				0.00

BELASTINGGENERATIE ALGEMEEN.

Betrouwbaarheidsklasse.....:	2	Referentieperiode.....:	50
Gebouwdiepte.....:	39.00	Gebouwhoogte.....:	19.50
Niveau aansl.terrein.....:	0.00	E.g. scheid.w. [kN/m2]:	0.00

WIND

Terrein categorie ...[4.3.2]...:	Onbebouwd
Windgebied	3 Vb,0 ..[4.2].....: 24.500
Positie spant in het gebouw....:	0.000 Kr ...[4.3.2].....: 0.209
z0	0.200 Zmin ..[4.3.2].....: 4.000
Co wind van links ..[4.3.3]...:	1.000 Co wind van rechts....: 1.000
Co wind loodrecht ..[4.3.3]...:	1.000
Cpi wind van links ..[7.2.9]...:	0.200 -0.300
Cpi windloodrecht ...[7.2.9]...:	0.200 -0.300
Cpi wind van rechts ..[7.2.9]...:	0.200 -0.300
Cfr windwrijving[7.5].....:	0.040

STAAFTYPEN

Type	staven
1:Vloer.	: 3-17-2,20-44-2,45,47,50,52,55,57,60,62,67,69
	: 83
4:Wand / kolom.	: 2-16-2,19-31-2,35-43-2,46,51,53,54,56,59,61
	: 63,70-84-2,85
5:Linker gevel.	: 1,49,66,68
6:Rechter gevel.	: 18,33,48,58
7:Dak.	: 64,65,71-81-2
9:Open.	: 86-95
Onderdeel.....:	

LASTVELDEN

Wind staven	Sneeuw staven
-------------	---------------

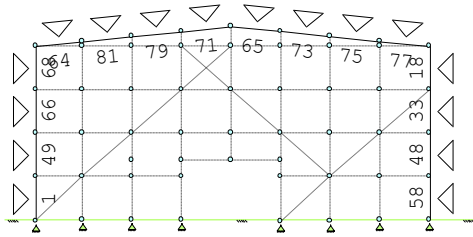

WIND DAKTYPES

Nr.	Staaftype	reductie bij wind van links	reductie bij wind van rechts	Cpe volgens art:
1	1-68 Gevel	1.000	1.000	7.2.2
2	64-71 Zadeldak	1.000	1.000	7.2.5
3	65-77 Zadeldak	1.000	1.000	7.2.5
4	18-58 Gevel	1.000	1.000	7.2.2

WIND ZONES

Wind van links Wind van rechts

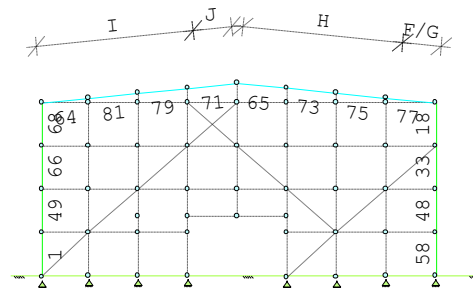
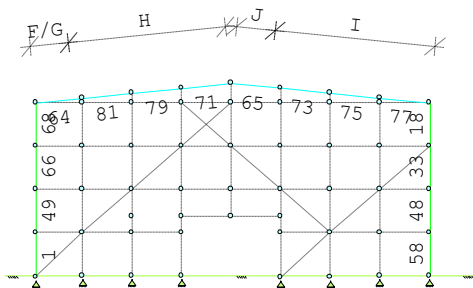

WIND VAN LINKS ZONES

Nr.	Staaftype	Positie	Lengte	Zone
1	1-68	0.000	17.618	D
2	64-71	0.000	3.900	F/G
3	64-71	3.900	15.901	H
4	65-77	0.000	3.900	J
5	65-77	3.900	16.200	I
6	18-58	0.000	17.500	E

WIND VAN RECHTS ZONES

Nr.	Staaftype	Positie	Lengte	Zone
1	18-58	0.000	17.500	D
2	65-77	0.000	3.900	F/G
3	65-77	3.900	16.200	H
4	64-71	0.000	3.900	J
5	64-71	3.900	15.901	I
6	1-68	0.000	17.618	E

Wind indexen

Index	CsCd	Cpe/Cpi	qp	breedte	reductie	Qw	Zone	Hoek(en)
Qw1		0.300	0.869	2.350		-0.613	-i	
Qw2	1.00	0.800	0.869	2.350		-1.634	D	
Qw3	1.00	0.016	0.869	2.350		-0.033	F	5.8
Qw4	1.00	0.016	0.869	2.350		-0.033	H	5.8
Qw5	1.00	-0.628	0.869	2.350		1.283	J	5.7
Qw6	1.00	-0.586	0.869	2.350		1.197	I	5.7
Qw7	1.00	-0.500	0.869	2.350		1.021	E	
Qw8		-0.200	0.869	2.350		0.408	+i	
Qw9	1.00	-1.636	0.869	2.350		3.341	F	5.8
Qw10	1.00	-0.576	0.869	2.350		1.176	H	5.8
Qw11	1.00	0.014	0.869	2.350		-0.028	F	5.7
Qw12	1.00	0.014	0.869	2.350		-0.028	H	5.7
Qw13	1.00	-0.632	0.869	2.350		1.291	J	5.8
Qw14	1.00	-0.584	0.869	2.350		1.193	I	5.8
Qw15	1.00	-1.644	0.869	2.350		3.358	F	5.7

Onderdeel.....:

Wind indexen

Index	CsCd	Cpe/Cpi	qp	breedte	reductie	Qw	Zone	Hoek(en)
Qw16	1.00	-0.579	0.869	2.350		1.183	H	5.7
Qw17	1.00	0.186	0.869	2.350		-0.380	J	5.7
Qw18	1.00	0.184	0.869	2.350		-0.376	J	5.8

BELASTINGGEVALLEN

B.G.	Omschrijving	Type
1	Permanente belasting EGZ=-1.00	1
g*	2 Wind van links onderdruk A	7
g*	3 Wind van links overdruk A	8
g*	4 Wind van links onderdruk B	9
g*	5 Wind van links overdruk B	10
g*	6 Wind van links onderdruk C	37
g*	7 Wind van links overdruk C	38

g*	8 Wind van links onderdruk D	39
g*	9 Wind van links overdruk D	40
g*	10 Wind van rechts onderdruk A	11
g*	11 Wind van rechts overdruk A	12
g*	12 Wind van rechts onderdruk B	13
g*	13 Wind van rechts overdruk B	14
g*	14 Wind van rechts onderdruk C	41
g*	15 Wind van rechts overdruk C	42
g*	16 Wind van rechts onderdruk D	43
g*	17 Wind van rechts overdruk D	44
	18 SNEEUW	22 Sneeuw A
	19 Knik	0 Onbekend

g = gegeneerd belastinggeval
 * = belastinggeval bevat 1 of meer handmatig toegevoegde en/of gewijzigde lasten

BELASTINGEN B.G:1 Permanente belasting

Eigen gewicht van alle staven is meegenomen in berekening. Richting: ↓

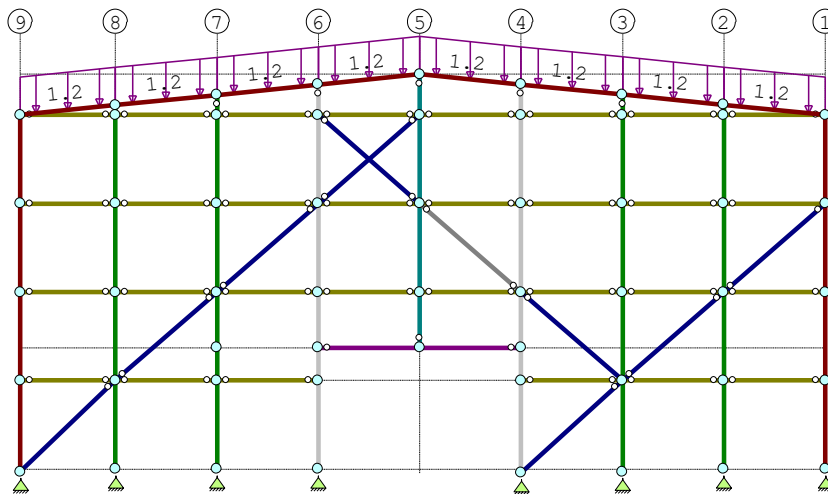

STAAFBELASTINGEN B.G:1 Permanente belasting

Staf	Type	q1/p/m	q2	A	B	ψ ₀	ψ ₁	ψ ₂
64	5:QZGlobaal	-1.20	-1.20	0.000	0.000			
81	5:QZGlobaal	-1.20	-1.20	0.000	0.000			
79	5:QZGlobaal	-1.20	-1.20	0.000	0.000			
71	5:QZGlobaal	-1.20	-1.20	0.000	0.000			
65	5:QZGlobaal	-1.20	-1.20	0.000	0.000			
73	5:QZGlobaal	-1.20	-1.20	0.000	0.000			
75	5:QZGlobaal	-1.20	-1.20	0.000	0.000			

Onderdeel....:

STAAFBELASTINGEN B.G:1 Permanente belasting

Staf	Type	q1/p/m	q2	A	B	ψ ₀	ψ ₁	ψ ₂
77	5:QZGlobaal	-1.20	-1.20	0.000	0.000			

REACTIES B.G:1 Permanente belasting

Kn.	X	Z	M
1	1.87	12.13	
3	-0.09	30.17	
4	-0.17	29.82	
5	-0.05	40.88	
7	-1.25	47.51	
8	-0.17	35.17	
9	-0.13	28.62	
10	-0.00	10.10	
	0.00	234.39	: Som van de reacties
	0.00	-234.39	: Som van de belastingen

BELASTINGEN B.G:2 Wind van links onderdruk A

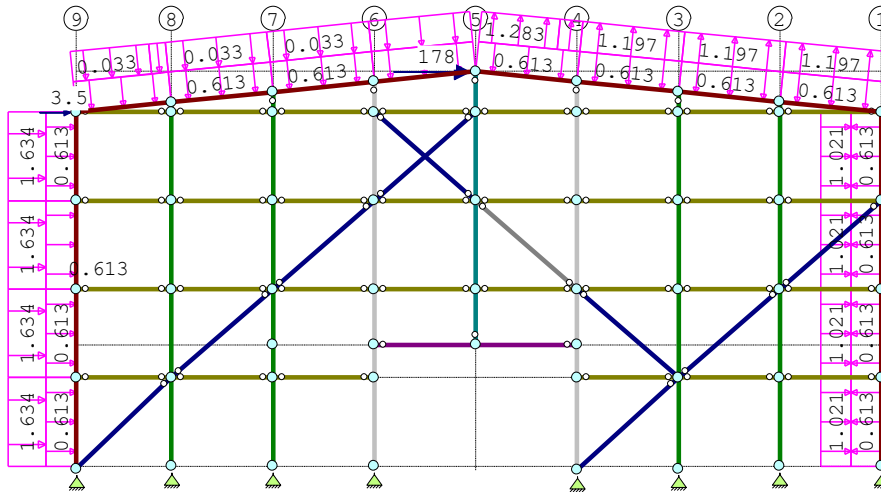

KNOOPBELASTINGEN

B.G:2 Wind van links onderdruk A

Last	Knoop	Richting	waarde	Ψ_0	Ψ_1	Ψ_2	Opm.
1	6	X	178.000	0.00	0.20	0.00	*
2	2	X	3.500	0.00	0.20	0.00	*

Opmerkingen

[*] Deze belasting is handmatig toegevoegd of gewijzigd.

STAAFBELASTINGEN

B.G:2 Wind van links onderdruk A

Staatf	Type	Index	q1/p/m	q2	A	B	Ψ_0	Ψ_1	Ψ_2
1	1:QZLokaal	Qw1	-0.61	-0.61	0.118	0.000	0.00	0.20	0.00
49	1:QZLokaal	Qw1	-0.61	-0.61	0.000	0.000	0.00	0.20	0.00
66	1:QZLokaal	Qw1	-0.61	-0.61	0.000	0.000	0.00	0.20	0.00
68	1:QZLokaal	Qw1	-0.61	-0.61	0.000	0.000	0.00	0.20	0.00
64	1:QZLokaal	Qw1	-0.61	-0.61	0.000	0.000	0.00	0.20	0.00
81	1:QZLokaal	Qw1	-0.61	-0.61	0.000	0.000	0.00	0.20	0.00
79	1:QZLokaal	Qw1	-0.61	-0.61	0.000	0.000	0.00	0.20	0.00
71	1:QZLokaal	Qw1	-0.61	-0.61	0.000	0.000	0.00	0.20	0.00
65	1:QZLokaal	Qw1	-0.61	-0.61	0.000	0.000	0.00	0.20	0.00
73	1:QZLokaal	Qw1	-0.61	-0.61	0.000	0.000	0.00	0.20	0.00
75	1:QZLokaal	Qw1	-0.61	-0.61	0.000	0.000	0.00	0.20	0.00
77	1:QZLokaal	Qw1	-0.61	-0.61	0.000	0.000	0.00	0.20	0.00
18	1:QZLokaal	Qw1	-0.61	-0.61	0.000	0.000	0.00	0.20	0.00
33	1:QZLokaal	Qw1	-0.61	-0.61	0.000	0.000	0.00	0.20	0.00
48	1:QZLokaal	Qw1	-0.61	-0.61	0.000	0.000	0.00	0.20	0.00
58	1:QZLokaal	Qw1	-0.61	-0.61	0.000	0.000	0.00	0.20	0.00
1	1:QZLokaal	Qw2	-1.63	-1.63	0.118	0.000	0.00	0.20	0.00

Onderdeel.....:

STAAFBELASTINGEN

B.G:2 Wind van links onderdruk A

Staatf	Type	Index	q1/p/m	q2	A	B	Ψ_0	Ψ_1	Ψ_2
49	1:QZLokaal	Qw2	-1.63	-1.63	0.000	0.000	0.00	0.20	0.00
66	1:QZLokaal	Qw2	-1.63	-1.63	0.000	0.000	0.00	0.20	0.00
68	1:QZLokaal	Qw2	-1.63	-1.63	0.000	0.000	0.00	0.20	0.00
64	1:QZLokaal	Qw3	-0.03	-0.03	0.000	0.824	0.00	0.20	0.00
64	1:QZLokaal	Qw4	-0.03	-0.03	3.900	0.000	0.00	0.20	0.00
81	1:QZLokaal	Qw4	-0.03	-0.03	0.000	0.000	0.00	0.20	0.00
79	1:QZLokaal	Qw4	-0.03	-0.03	0.000	0.000	0.00	0.20	0.00
71	1:QZLokaal	Qw4	-0.03	-0.03	0.000	0.000	0.00	0.20	0.00
65	1:QZLokaal	Qw5	1.28	1.28	0.000	1.125	0.00	0.20	0.00
65	1:QZLokaal	Qw6	1.20	1.20	3.900	0.000	0.00	0.20	0.00
73	1:QZLokaal	Qw6	1.20	1.20	0.000	0.000	0.00	0.20	0.00
75	1:QZLokaal	Qw6	1.20	1.20	0.000	0.000	0.00	0.20	0.00
77	1:QZLokaal	Qw6	1.20	1.20	0.000	0.000	0.00	0.20	0.00
18	1:QZLokaal	Qw7	1.02	1.02	0.000	0.000	0.00	0.20	0.00
33	1:QZLokaal	Qw7	1.02	1.02	0.000	0.000	0.00	0.20	0.00
48	1:QZLokaal	Qw7	1.02	1.02	0.000	0.000	0.00	0.20	0.00
58	1:QZLokaal	Qw7	1.02	1.02	0.000	0.000	0.00	0.20	0.00

REACTIES

B.G:2 Wind van links onderdruk A

Kn.	X	Z	M
1	-103.58	-97.20	
3	-0.78	28.62	
4	-1.32	8.10	
5	-1.16	-83.33	
7	-117.78	-28.28	
8	-2.10	128.61	
9	-2.94	14.85	
10	-0.79	29.33	
	-230.46	0.70	: Som van de reacties
	230.46	-0.70	: Som van de belastingen

BELASTINGEN

B.G:3 Wind van links overdruk A

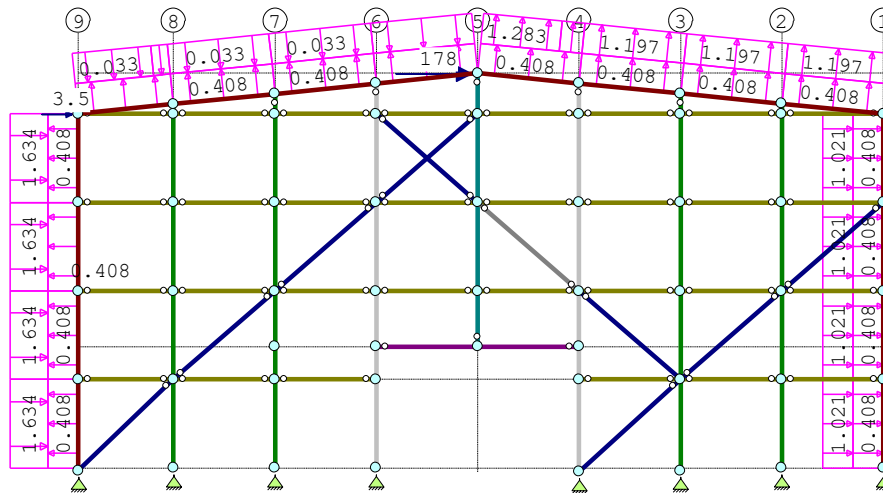

KNOOPBELASTINGEN

B.G:3 Wind van links overdruk A

Last	Knoop	Richting	waarde	Ψ_0	Ψ_1	Ψ_2	Opm.
1	6	X	178.000	0.00	0.20	0.00	*
2	2	X	3.500	0.00	0.20	0.00	*

Opmerkingen

[*] Deze belasting is handmatig toegevoegd of gewijzigd.

Onderdeel.....:

STAAFBELASTINGEN

B.G:3 Wind van links overdruk A

Staaftype	Type	Index	q1/p/m	q2	A	B	Ψ_0	Ψ_1	Ψ_2
1	1:QZLokaal	Qw8	0.41	0.41	0.118	0.000	0.00	0.20	0.00
49	1:QZLokaal	Qw8	0.41	0.41	0.000	0.000	0.00	0.20	0.00
66	1:QZLokaal	Qw8	0.41	0.41	0.000	0.000	0.00	0.20	0.00
68	1:QZLokaal	Qw8	0.41	0.41	0.000	0.000	0.00	0.20	0.00
64	1:QZLokaal	Qw8	0.41	0.41	0.000	0.000	0.00	0.20	0.00
81	1:QZLokaal	Qw8	0.41	0.41	0.000	0.000	0.00	0.20	0.00
79	1:QZLokaal	Qw8	0.41	0.41	0.000	0.000	0.00	0.20	0.00
71	1:QZLokaal	Qw8	0.41	0.41	0.000	0.000	0.00	0.20	0.00
65	1:QZLokaal	Qw8	0.41	0.41	0.000	0.000	0.00	0.20	0.00
73	1:QZLokaal	Qw8	0.41	0.41	0.000	0.000	0.00	0.20	0.00
75	1:QZLokaal	Qw8	0.41	0.41	0.000	0.000	0.00	0.20	0.00
77	1:QZLokaal	Qw8	0.41	0.41	0.000	0.000	0.00	0.20	0.00
18	1:QZLokaal	Qw8	0.41	0.41	0.000	0.000	0.00	0.20	0.00
33	1:QZLokaal	Qw8	0.41	0.41	0.000	0.000	0.00	0.20	0.00
48	1:QZLokaal	Qw8	0.41	0.41	0.000	0.000	0.00	0.20	0.00
58	1:QZLokaal	Qw8	0.41	0.41	0.000	0.000	0.00	0.20	0.00
1	1:QZLokaal	Qw2	-1.63	-1.63	0.118	0.000	0.00	0.20	0.00
49	1:QZLokaal	Qw2	-1.63	-1.63	0.000	0.000	0.00	0.20	0.00
66	1:QZLokaal	Qw2	-1.63	-1.63	0.000	0.000	0.00	0.20	0.00
68	1:QZLokaal	Qw2	-1.63	-1.63	0.000	0.000	0.00	0.20	0.00
64	1:QZLokaal	Qw3	-0.03	-0.03	0.000	0.824	0.00	0.20	0.00
64	1:QZLokaal	Qw4	-0.03	-0.03	3.900	0.000	0.00	0.20	0.00
81	1:QZLokaal	Qw4	-0.03	-0.03	0.000	0.000	0.00	0.20	0.00
79	1:QZLokaal	Qw4	-0.03	-0.03	0.000	0.000	0.00	0.20	0.00
71	1:QZLokaal	Qw4	-0.03	-0.03	0.000	0.000	0.00	0.20	0.00
65	1:QZLokaal	Qw5	1.28	1.28	0.000	1.125	0.00	0.20	0.00
65	1:QZLokaal	Qw6	1.20	1.20	3.900	0.000	0.00	0.20	0.00
73	1:QZLokaal	Qw6	1.20	1.20	0.000	0.000	0.00	0.20	0.00
75	1:QZLokaal	Qw6	1.20	1.20	0.000	0.000	0.00	0.20	0.00
77	1:QZLokaal	Qw6	1.20	1.20	0.000	0.000	0.00	0.20	0.00
18	1:QZLokaal	Qw7	1.02	1.02	0.000	0.000	0.00	0.20	0.00
33	1:QZLokaal	Qw7	1.02	1.02	0.000	0.000	0.00	0.20	0.00
48	1:QZLokaal	Qw7	1.02	1.02	0.000	0.000	0.00	0.20	0.00
58	1:QZLokaal	Qw7	1.02	1.02	0.000	0.000	0.00	0.20	0.00

REACTIES

B.G:3 Wind van links overdruk A

Kn.	X	Z	M
1	-98.93	-96.93	
3	-0.77	20.68	
4	-1.29	1.76	
5	-0.93	-88.04	
7	-120.67	-37.48	
8	-2.16	121.48	
9	-3.14	10.83	
10	-2.57	27.87	
	-230.46	-39.84	: Som van de reacties
	230.46	39.84	: Som van de belastingen

Onderdeel.....:

BELASTINGEN

B.G:4 Wind van links onderdruk B

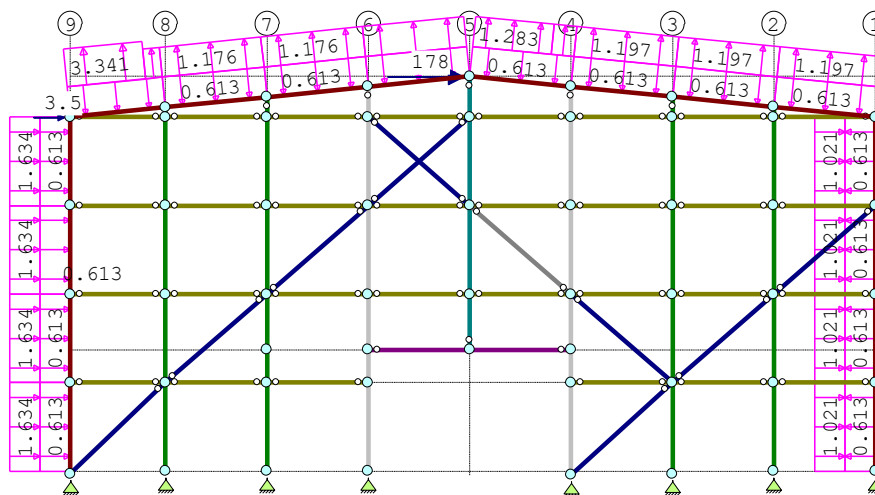

KNOOPBELASTINGEN

B.G:4 Wind van links onderdruk B

Last	Knoop	Richting	waarde	Ψ_0	Ψ_1	Ψ_2	Opm.
1	6	X	178.000	0.00	0.20	0.00	*
2	2	X	3.500	0.00	0.20	0.00	*

Opmerkingen

[*] Deze belasting is handmatig toegevoegd of gewijzigd.

STAAFBELASTINGEN

B.G:4 Wind van links onderdruk B

Staat	Type	Index	q1/p/m	q2	A	B	Ψ_0	Ψ_1	Ψ_2
1	1:QZLokaal	Qw1	-0.61	-0.61	0.118	0.000	0.00	0.20	0.00
49	1:QZLokaal	Qw1	-0.61	-0.61	0.000	0.000	0.00	0.20	0.00
66	1:QZLokaal	Qw1	-0.61	-0.61	0.000	0.000	0.00	0.20	0.00
68	1:QZLokaal	Qw1	-0.61	-0.61	0.000	0.000	0.00	0.20	0.00
64	1:QZLokaal	Qw1	-0.61	-0.61	0.000	0.000	0.00	0.20	0.00
81	1:QZLokaal	Qw1	-0.61	-0.61	0.000	0.000	0.00	0.20	0.00
79	1:QZLokaal	Qw1	-0.61	-0.61	0.000	0.000	0.00	0.20	0.00
71	1:QZLokaal	Qw1	-0.61	-0.61	0.000	0.000	0.00	0.20	0.00
65	1:QZLokaal	Qw1	-0.61	-0.61	0.000	0.000	0.00	0.20	0.00
73	1:QZLokaal	Qw1	-0.61	-0.61	0.000	0.000	0.00	0.20	0.00
75	1:QZLokaal	Qw1	-0.61	-0.61	0.000	0.000	0.00	0.20	0.00
77	1:QZLokaal	Qw1	-0.61	-0.61	0.000	0.000	0.00	0.20	0.00
18	1:QZLokaal	Qw1	-0.61	-0.61	0.000	0.000	0.00	0.20	0.00
33	1:QZLokaal	Qw1	-0.61	-0.61	0.000	0.000	0.00	0.20	0.00
48	1:QZLokaal	Qw1	-0.61	-0.61	0.000	0.000	0.00	0.20	0.00
58	1:QZLokaal	Qw1	-0.61	-0.61	0.000	0.000	0.00	0.20	0.00
1	1:QZLokaal	Qw2	-1.63	-1.63	0.118	0.000	0.00	0.20	0.00
49	1:QZLokaal	Qw2	-1.63	-1.63	0.000	0.000	0.00	0.20	0.00
66	1:QZLokaal	Qw2	-1.63	-1.63	0.000	0.000	0.00	0.20	0.00
68	1:QZLokaal	Qw2	-1.63	-1.63	0.000	0.000	0.00	0.20	0.00
64	1:QZLokaal	Qw9	3.34	3.34	0.000	0.824	0.00	0.20	0.00
64	1:QZLokaal	Qw10	1.18	1.18	3.900	0.000	0.00	0.20	0.00
81	1:QZLokaal	Qw10	1.18	1.18	0.000	0.000	0.00	0.20	0.00
79	1:QZLokaal	Qw10	1.18	1.18	0.000	0.000	0.00	0.20	0.00
71	1:QZLokaal	Qw10	1.18	1.18	0.000	0.000	0.00	0.20	0.00
65	1:QZLokaal	Qw5	1.28	1.28	0.000	1.125	0.00	0.20	0.00
65	1:QZLokaal	Qw6	1.20	1.20	3.900	0.000	0.00	0.20	0.00
73	1:QZLokaal	Qw6	1.20	1.20	0.000	0.000	0.00	0.20	0.00
75	1:QZLokaal	Qw6	1.20	1.20	0.000	0.000	0.00	0.20	0.00
77	1:QZLokaal	Qw6	1.20	1.20	0.000	0.000	0.00	0.20	0.00
18	1:QZLokaal	Qw7	1.02	1.02	0.000	0.000	0.00	0.20	0.00
33	1:QZLokaal	Qw7	1.02	1.02	0.000	0.000	0.00	0.20	0.00
48	1:QZLokaal	Qw7	1.02	1.02	0.000	0.000	0.00	0.20	0.00
58	1:QZLokaal	Qw7	1.02	1.02	0.000	0.000	0.00	0.20	0.00

Onderdeel.....:

REACTIES

B.G:4 Wind van links onderdruk B

Kn.	X	Z	M
1	-102.71	-103.81	
3	-0.75	17.88	
4	-1.27	2.67	
5	-1.11	-88.20	
7	-115.60	-29.21	
8	-2.07	125.69	
9	-2.88	14.52	
10	-0.79	28.95	
			: Som van de reacties
			: Som van de belastingen

BELASTINGEN

B.G:5 Wind van links overdruk B

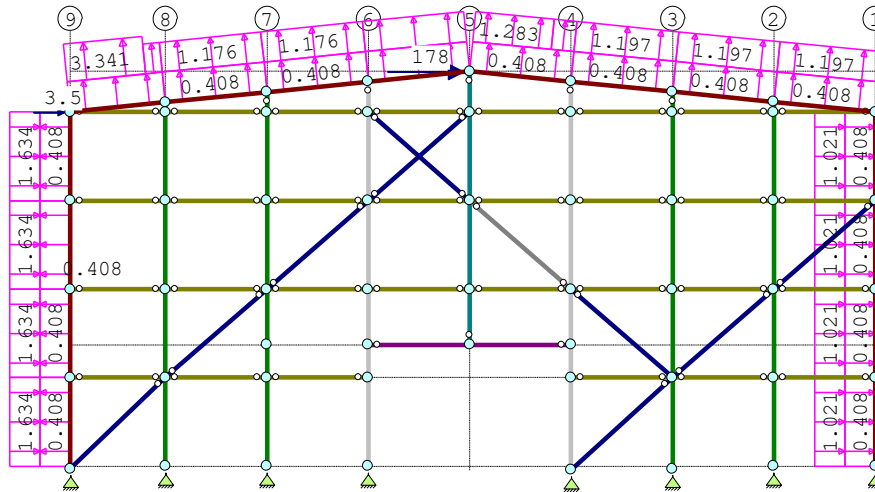

KNOOPBELASTINGEN

B.G:5 Wind van links overdruk B

Last	Knoop	Richting	waarde	Ψ_0	Ψ_1	Ψ_2	Opm.
1	6	X	178.000	0.00	0.20	0.00	*
2	2	X	3.500	0.00	0.20	0.00	*

Opmerkingen

[*] Deze belasting is handmatig toegevoegd of gewijzigd.

STAAFBELASTINGEN

B.G:5 Wind van links overdruk B

Staaftype	Index	q1/p/m	q2	A	B	Ψ_0	Ψ_1	Ψ_2
1 1:QZLokaal	Qw8	0.41	0.41	0.118	0.000	0.00	0.20	0.00
49 1:QZLokaal	Qw8	0.41	0.41	0.000	0.000	0.00	0.20	0.00
66 1:QZLokaal	Qw8	0.41	0.41	0.000	0.000	0.00	0.20	0.00
68 1:QZLokaal	Qw8	0.41	0.41	0.000	0.000	0.00	0.20	0.00
64 1:QZLokaal	Qw8	0.41	0.41	0.000	0.000	0.00	0.20	0.00
81 1:QZLokaal	Qw8	0.41	0.41	0.000	0.000	0.00	0.20	0.00
79 1:QZLokaal	Qw8	0.41	0.41	0.000	0.000	0.00	0.20	0.00
71 1:QZLokaal	Qw8	0.41	0.41	0.000	0.000	0.00	0.20	0.00
65 1:QZLokaal	Qw8	0.41	0.41	0.000	0.000	0.00	0.20	0.00
73 1:QZLokaal	Qw8	0.41	0.41	0.000	0.000	0.00	0.20	0.00
75 1:QZLokaal	Qw8	0.41	0.41	0.000	0.000	0.00	0.20	0.00
77 1:QZLokaal	Qw8	0.41	0.41	0.000	0.000	0.00	0.20	0.00
18 1:QZLokaal	Qw8	0.41	0.41	0.000	0.000	0.00	0.20	0.00
33 1:QZLokaal	Qw8	0.41	0.41	0.000	0.000	0.00	0.20	0.00
48 1:QZLokaal	Qw8	0.41	0.41	0.000	0.000	0.00	0.20	0.00
58 1:QZLokaal	Qw8	0.41	0.41	0.000	0.000	0.00	0.20	0.00
1 1:QZLokaal	Qw2	-1.63	-1.63	0.118	0.000	0.00	0.20	0.00
49 1:QZLokaal	Qw2	-1.63	-1.63	0.000	0.000	0.00	0.20	0.00
66 1:QZLokaal	Qw2	-1.63	-1.63	0.000	0.000	0.00	0.20	0.00
68 1:QZLokaal	Qw2	-1.63	-1.63	0.000	0.000	0.00	0.20	0.00
64 1:QZLokaal	Qw9	3.34	3.34	0.000	0.824	0.00	0.20	0.00

Onderdeel.....:

STAAFBELASTINGEN

B.G:5 Wind van links overdruk B

Staaftype	Index	q1/p/m	q2	A	B	Ψ_0	Ψ_1	Ψ_2
64 1:QZLokaal	Qw10	1.18	1.18	3.900	0.000	0.00	0.20	0.00
81 1:QZLokaal	Qw10	1.18	1.18	0.000	0.000	0.00	0.20	0.00
79 1:QZLokaal	Qw10	1.18	1.18	0.000	0.000	0.00	0.20	0.00
71 1:QZLokaal	Qw10	1.18	1.18	0.000	0.000	0.00	0.20	0.00
65 1:QZLokaal	Qw5	1.28	1.28	0.000	1.125	0.00	0.20	0.00
65 1:QZLokaal	Qw6	1.20	1.20	3.900	0.000	0.00	0.20	0.00
73 1:QZLokaal	Qw6	1.20	1.20	0.000	0.000	0.00	0.20	0.00
75 1:QZLokaal	Qw6	1.20	1.20	0.000	0.000	0.00	0.20	0.00
77 1:QZLokaal	Qw6	1.20	1.20	0.000	0.000	0.00	0.20	0.00
18 1:QZLokaal	Qw7	1.02	1.02	0.000	0.000	0.00	0.20	0.00
33 1:QZLokaal	Qw7	1.02	1.02	0.000	0.000	0.00	0.20	0.00
48 1:QZLokaal	Qw7	1.02	1.02	0.000	0.000	0.00	0.20	0.00
58 1:QZLokaal	Qw7	1.02	1.02	0.000	0.000	0.00	0.20	0.00

REACTIES

B.G:5 Wind van links overdruk B

Kn.	X	Z	M
1	-98.07	-103.55	
3	-0.74	9.94	
4	-1.24	-3.68	
5	-0.88	-92.91	
7	-118.48	-38.41	
8	-2.13	118.56	
9	-3.08	10.50	
10	-2.57	27.48	
	-227.18	-72.06	: Som van de reacties
	227.18	72.06	: Som van de belastingen

BELASTINGEN

B.G:6 Wind van links onderdruk C

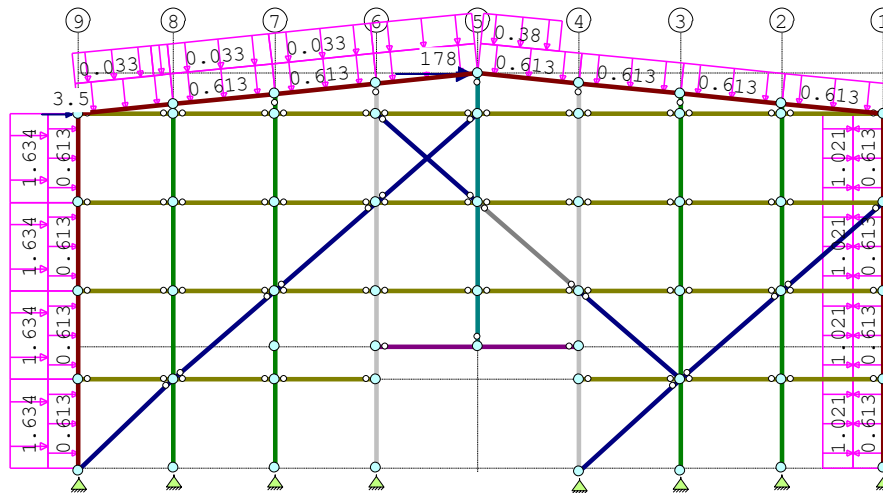

KNOOPBELASTINGEN

B.G:6 Wind van links onderdruk C

Last	Knoop	Richting	waarde	Ψ_0	Ψ_1	Ψ_2	Opm.
1	6	X	178.000	0.00	0.20	0.00	*
2	2	X	3.500	0.00	0.20	0.00	*

Opmerkingen

[*] Deze belasting is handmatig toegevoegd of gewijzigd.

Onderdeel.....:

STAAFBELASTINGEN

B.G:6 Wind van links onderdruk C

StAAF	Type	Index	q1/p/m	q2	A	B	Ψ_0	Ψ_1	Ψ_2
1	1:QZLokaal	Qw1	-0.61	-0.61	0.118	0.000	0.00	0.20	0.00
49	1:QZLokaal	Qw1	-0.61	-0.61	0.000	0.000	0.00	0.20	0.00
66	1:QZLokaal	Qw1	-0.61	-0.61	0.000	0.000	0.00	0.20	0.00
68	1:QZLokaal	Qw1	-0.61	-0.61	0.000	0.000	0.00	0.20	0.00
64	1:QZLokaal	Qw1	-0.61	-0.61	0.000	0.000	0.00	0.20	0.00
81	1:QZLokaal	Qw1	-0.61	-0.61	0.000	0.000	0.00	0.20	0.00
79	1:QZLokaal	Qw1	-0.61	-0.61	0.000	0.000	0.00	0.20	0.00
71	1:QZLokaal	Qw1	-0.61	-0.61	0.000	0.000	0.00	0.20	0.00
65	1:QZLokaal	Qw1	-0.61	-0.61	0.000	0.000	0.00	0.20	0.00
73	1:QZLokaal	Qw1	-0.61	-0.61	0.000	0.000	0.00	0.20	0.00
75	1:QZLokaal	Qw1	-0.61	-0.61	0.000	0.000	0.00	0.20	0.00
77	1:QZLokaal	Qw1	-0.61	-0.61	0.000	0.000	0.00	0.20	0.00
18	1:QZLokaal	Qw1	-0.61	-0.61	0.000	0.000	0.00	0.20	0.00
33	1:QZLokaal	Qw1	-0.61	-0.61	0.000	0.000	0.00	0.20	0.00
48	1:QZLokaal	Qw1	-0.61	-0.61	0.000	0.000	0.00	0.20	0.00
58	1:QZLokaal	Qw1	-0.61	-0.61	0.000	0.000	0.00	0.20	0.00
1	1:QZLokaal	Qw2	-1.63	-1.63	0.118	0.000	0.00	0.20	0.00
49	1:QZLokaal	Qw2	-1.63	-1.63	0.000	0.000	0.00	0.20	0.00
66	1:QZLokaal	Qw2	-1.63	-1.63	0.000	0.000	0.00	0.20	0.00
68	1:QZLokaal	Qw2	-1.63	-1.63	0.000	0.000	0.00	0.20	0.00
64	1:QZLokaal	Qw3	-0.03	-0.03	0.000	0.824	0.00	0.20	0.00
64	1:QZLokaal	Qw4	-0.03	-0.03	3.900	0.000	0.00	0.20	0.00
81	1:QZLokaal	Qw4	-0.03	-0.03	0.000	0.000	0.00	0.20	0.00
79	1:QZLokaal	Qw4	-0.03	-0.03	0.000	0.000	0.00	0.20	0.00
71	1:QZLokaal	Qw4	-0.03	-0.03	0.000	0.000	0.00	0.20	0.00
65	1:QZLokaal	Qw17	-0.38	-0.38	0.000	1.125	0.00	0.20	0.00
18	1:QZLokaal	Qw7	1.02	1.02	0.000	0.000	0.00	0.20	0.00
33	1:QZLokaal	Qw7	1.02	1.02	0.000	0.000	0.00	0.20	0.00
48	1:QZLokaal	Qw7	1.02	1.02	0.000	0.000	0.00	0.20	0.00
58	1:QZLokaal	Qw7	1.02	1.02	0.000	0.000	0.00	0.20	0.00

REACTIES

B.G:6 Wind van links onderdruk C

Kn.	X	Z	M
1	-102.36	-96.03	
3	-0.79	28.66	
4	-1.34	8.41	
5	-1.15	-81.46	
7	-116.44	-19.23	
8	-2.09	133.62	
9	-2.92	20.96	
10	-0.79	31.53	
	-227.88	26.44	: Som van de reacties
	227.88	-26.44	: Som van de belastingen

Onderdeel.....:

BELASTINGEN

B.G:7 Wind van links overdruk C

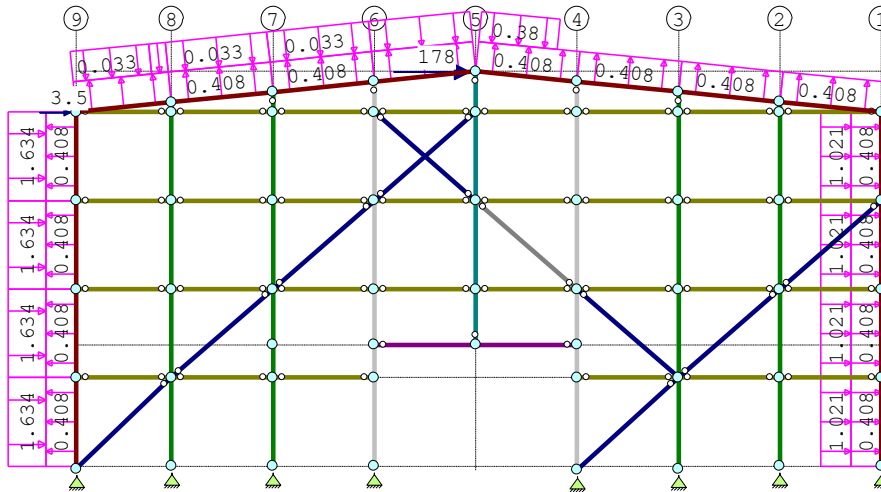

KNOOPBELASTINGEN

B.G:7 Wind van links overdruk C

Last	Knoop	Richting	waarde	Ψ_0	Ψ_1	Ψ_2	Opm.
1	6	X	178.000	0.00	0.20	0.00	*
2	2	X	3.500	0.00	0.20	0.00	*

Opmerkingen

[*] Deze belasting is handmatig toegevoegd of gewijzigd.

STAAFBELASTINGEN

B.G:7 Wind van links overdruk C

Staat	Type	Index	q1/p/m	q2	A	B	Ψ_0	Ψ_1	Ψ_2
1	1:QZLokaal	Qw8	0.41	0.41	0.118	0.000	0.00	0.20	0.00
49	1:QZLokaal	Qw8	0.41	0.41	0.000	0.000	0.00	0.20	0.00
66	1:QZLokaal	Qw8	0.41	0.41	0.000	0.000	0.00	0.20	0.00
68	1:QZLokaal	Qw8	0.41	0.41	0.000	0.000	0.00	0.20	0.00
64	1:QZLokaal	Qw8	0.41	0.41	0.000	0.000	0.00	0.20	0.00
81	1:QZLokaal	Qw8	0.41	0.41	0.000	0.000	0.00	0.20	0.00
79	1:QZLokaal	Qw8	0.41	0.41	0.000	0.000	0.00	0.20	0.00
71	1:QZLokaal	Qw8	0.41	0.41	0.000	0.000	0.00	0.20	0.00
65	1:QZLokaal	Qw8	0.41	0.41	0.000	0.000	0.00	0.20	0.00
73	1:QZLokaal	Qw8	0.41	0.41	0.000	0.000	0.00	0.20	0.00
75	1:QZLokaal	Qw8	0.41	0.41	0.000	0.000	0.00	0.20	0.00
77	1:QZLokaal	Qw8	0.41	0.41	0.000	0.000	0.00	0.20	0.00
18	1:QZLokaal	Qw8	0.41	0.41	0.000	0.000	0.00	0.20	0.00
33	1:QZLokaal	Qw8	0.41	0.41	0.000	0.000	0.00	0.20	0.00
48	1:QZLokaal	Qw8	0.41	0.41	0.000	0.000	0.00	0.20	0.00
58	1:QZLokaal	Qw8	0.41	0.41	0.000	0.000	0.00	0.20	0.00
1	1:QZLokaal	Qw2	-1.63	-1.63	0.118	0.000	0.00	0.20	0.00
49	1:QZLokaal	Qw2	-1.63	-1.63	0.000	0.000	0.00	0.20	0.00
66	1:QZLokaal	Qw2	-1.63	-1.63	0.000	0.000	0.00	0.20	0.00
68	1:QZLokaal	Qw2	-1.63	-1.63	0.000	0.000	0.00	0.20	0.00
64	1:QZLokaal	Qw3	-0.03	-0.03	0.000	0.824	0.00	0.20	0.00
81	1:QZLokaal	Qw4	-0.03	-0.03	3.900	0.000	0.00	0.20	0.00
79	1:QZLokaal	Qw4	-0.03	-0.03	0.000	0.000	0.00	0.20	0.00
71	1:QZLokaal	Qw4	-0.03	-0.03	0.000	0.000	0.00	0.20	0.00
65	1:QZLokaal	Qw17	-0.38	-0.38	0.000	1.125	0.00	0.20	0.00
18	1:QZLokaal	Qw7	1.02	1.02	0.000	0.000	0.00	0.20	0.00
33	1:QZLokaal	Qw7	1.02	1.02	0.000	0.000	0.00	0.20	0.00
48	1:QZLokaal	Qw7	1.02	1.02	0.000	0.000	0.00	0.20	0.00
58	1:QZLokaal	Qw7	1.02	1.02	0.000	0.000	0.00	0.20	0.00

Onderdeel.....

REACTIES

B.G:7 Wind van links overdruk C

Kn.	X	Z	M
1	-97.72	-95.77	
3	-0.77	20.72	
4	-1.30	2.07	
5	-0.92	-86.17	
7	-119.33	-28.43	
8	-2.15	126.49	
9	-3.13	16.93	
10	-2.56	30.06	
	-227.88	-14.10	: Som van de reacties
	227.88	14.10	: Som van de belastingen

BELASTINGEN

B.G:8 Wind van links onderdruk D

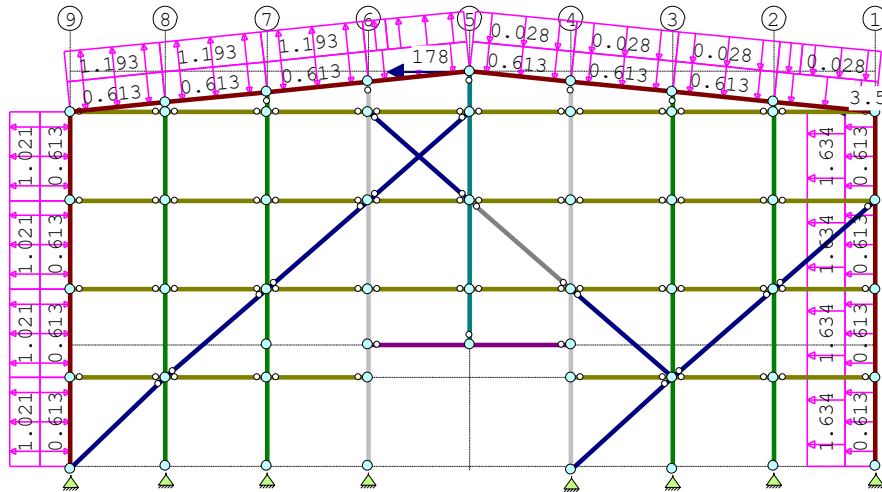

Onderdeel.....:

KNOOPBELASTINGEN

B.G:10 Wind van rechts onderdruk A

Last	Knoop	Richting	waarde	Ψ_0	Ψ_1	Ψ_2	Opm.
1	6	X	-178.000	0.00	0.20	0.00	*
2	18	X	-3.500	0.00	0.20	0.00	*

Opmerkingen

[*] Deze belasting is handmatig toegevoegd of gewijzigd.

STAAFBELASTINGEN

B.G:10 Wind van rechts onderdruk A

Staat	Type	Index	q1/p/m	q2	A	B	Ψ_0	Ψ_1	Ψ_2
1	1:QZLokaal	Qw1	-0.61	-0.61	0.118	0.000	0.00	0.20	0.00
49	1:QZLokaal	Qw1	-0.61	-0.61	0.000	0.000	0.00	0.20	0.00
66	1:QZLokaal	Qw1	-0.61	-0.61	0.000	0.000	0.00	0.20	0.00
68	1:QZLokaal	Qw1	-0.61	-0.61	0.000	0.000	0.00	0.20	0.00
64	1:QZLokaal	Qw1	-0.61	-0.61	0.000	0.000	0.00	0.20	0.00
81	1:QZLokaal	Qw1	-0.61	-0.61	0.000	0.000	0.00	0.20	0.00
79	1:QZLokaal	Qw1	-0.61	-0.61	0.000	0.000	0.00	0.20	0.00
71	1:QZLokaal	Qw1	-0.61	-0.61	0.000	0.000	0.00	0.20	0.00
65	1:QZLokaal	Qw1	-0.61	-0.61	0.000	0.000	0.00	0.20	0.00
73	1:QZLokaal	Qw1	-0.61	-0.61	0.000	0.000	0.00	0.20	0.00
75	1:QZLokaal	Qw1	-0.61	-0.61	0.000	0.000	0.00	0.20	0.00
77	1:QZLokaal	Qw1	-0.61	-0.61	0.000	0.000	0.00	0.20	0.00
18	1:QZLokaal	Qw1	-0.61	-0.61	0.000	0.000	0.00	0.20	0.00
33	1:QZLokaal	Qw1	-0.61	-0.61	0.000	0.000	0.00	0.20	0.00
48	1:QZLokaal	Qw1	-0.61	-0.61	0.000	0.000	0.00	0.20	0.00
58	1:QZLokaal	Qw1	-0.61	-0.61	0.000	0.000	0.00	0.20	0.00
58	1:QZLokaal	Qw2	-1.63	-1.63	0.000	0.000	0.00	0.20	0.00
48	1:QZLokaal	Qw2	-1.63	-1.63	0.000	0.000	0.00	0.20	0.00
33	1:QZLokaal	Qw2	-1.63	-1.63	0.000	0.000	0.00	0.20	0.00
18	1:QZLokaal	Qw2	-1.63	-1.63	0.000	0.000	0.00	0.20	0.00
77	1:QZLokaal	Qw11	-0.03	-0.03	1.125	0.000	0.00	0.20	0.00
77	1:QZLokaal	Qw12	-0.03	-0.03	0.000	3.900	0.00	0.20	0.00
75	1:QZLokaal	Qw12	-0.03	-0.03	0.000	0.000	0.00	0.20	0.00
73	1:QZLokaal	Qw12	-0.03	-0.03	0.000	0.000	0.00	0.20	0.00
65	1:QZLokaal	Qw12	-0.03	-0.03	0.000	0.000	0.00	0.20	0.00
71	1:QZLokaal	Qw13	1.29	1.29	1.126	0.000	0.00	0.20	0.00
71	1:QZLokaal	Qw14	1.19	1.19	0.000	3.900	0.00	0.20	0.00
79	1:QZLokaal	Qw14	1.19	1.19	0.000	0.000	0.00	0.20	0.00
81	1:QZLokaal	Qw14	1.19	1.19	0.000	0.000	0.00	0.20	0.00
64	1:QZLokaal	Qw14	1.19	1.19	0.000	0.000	0.00	0.20	0.00
68	1:QZLokaal	Qw7	1.02	1.02	0.000	0.000	0.00	0.20	0.00
66	1:QZLokaal	Qw7	1.02	1.02	0.000	0.000	0.00	0.20	0.00
49	1:QZLokaal	Qw7	1.02	1.02	0.000	0.000	0.00	0.20	0.00
1	1:QZLokaal	Qw7	1.02	1.02	0.118	0.000	0.00	0.20	0.00

REACTIES

B.G:10 Wind van rechts onderdruk A

Kn.	X	Z	M
1	94.47	92.63	
3	0.78	-24.27	
4	1.33	-5.97	
5	0.76	81.00	
7	123.55	31.66	
8	2.23	-126.76	
9	3.35	-16.95	
10	3.98	-30.33	
	230.44	1.02	: Som van de reacties
	-230.44	-1.02	: Som van de belastingen

Onderdeel.....:

BELASTINGEN

B.G:11 Wind van rechts overdruk A

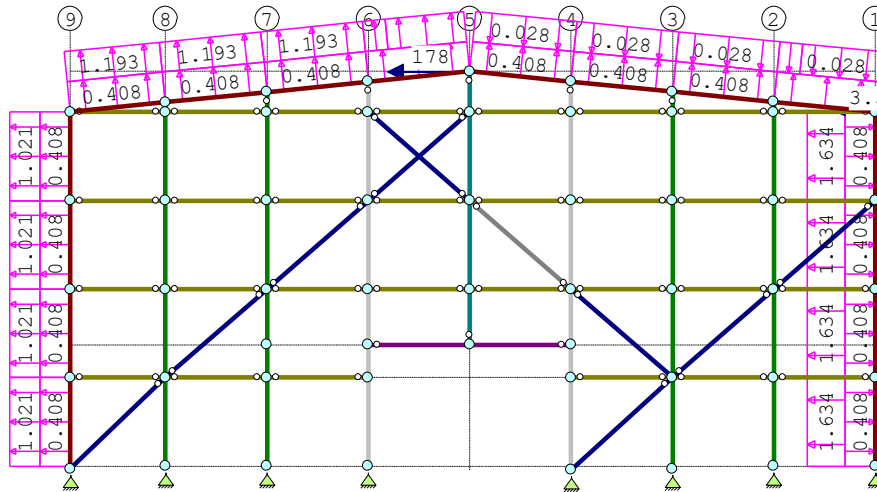

KNOOPBELASTINGEN

B.G:11 Wind van rechts overdruk A

Last	Knoop	Richting	waarde	Ψ_0	Ψ_1	Ψ_2	Opm.
1	6	X	-178.000	0.00	0.20	0.00	*
2	18	X	-3.500	0.00	0.20	0.00	*

Opmerkingen

[*] Deze belasting is handmatig toegevoegd of gewijzigd.

STAAFBELASTINGEN

B.G:11 Wind van rechts overdruk A

Staat	Type	Index	q1/p/m	q2	A	B	Ψ_0	Ψ_1	Ψ_2
1	1:QZLokaal	Qw8	0.41	0.41	0.118	0.000	0.00	0.20	0.00
49	1:QZLokaal	Qw8	0.41	0.41	0.000	0.000	0.00	0.20	0.00
66	1:QZLokaal	Qw8	0.41	0.41	0.000	0.000	0.00	0.20	0.00
68	1:QZLokaal	Qw8	0.41	0.41	0.000	0.000	0.00	0.20	0.00
64	1:QZLokaal	Qw8	0.41	0.41	0.000	0.000	0.00	0.20	0.00
81	1:QZLokaal	Qw8	0.41	0.41	0.000	0.000	0.00	0.20	0.00
79	1:QZLokaal	Qw8	0.41	0.41	0.000	0.000	0.00	0.20	0.00
71	1:QZLokaal	Qw8	0.41	0.41	0.000	0.000	0.00	0.20	0.00
65	1:QZLokaal	Qw8	0.41	0.41	0.000	0.000	0.00	0.20	0.00
73	1:QZLokaal	Qw8	0.41	0.41	0.000	0.000	0.00	0.20	0.00
75	1:QZLokaal	Qw8	0.41	0.41	0.000	0.000	0.00	0.20	0.00
77	1:QZLokaal	Qw8	0.41	0.41	0.000	0.000	0.00	0.20	0.00
18	1:QZLokaal	Qw8	0.41	0.41	0.000	0.000	0.00	0.20	0.00
33	1:QZLokaal	Qw8	0.41	0.41	0.000	0.000	0.00	0.20	0.00
48	1:QZLokaal	Qw8	0.41	0.41	0.000	0.000	0.00	0.20	0.00
58	1:QZLokaal	Qw8	0.41	0.41	0.000	0.000	0.00	0.20	0.00
58	1:QZLokaal	Qw2	-1.63	-1.63	0.000	0.000	0.00	0.20	0.00
48	1:QZLokaal	Qw2	-1.63	-1.63	0.000	0.000	0.00	0.20	0.00
33	1:QZLokaal	Qw2	-1.63	-1.63	0.000	0.000	0.00	0.20	0.00
18	1:QZLokaal	Qw2	-1.63	-1.63	0.000	0.000	0.00	0.20	0.00
77	1:QZLokaal	Qw11	-0.03	-0.03	1.125	0.000	0.00	0.20	0.00
77	1:QZLokaal	Qw12	-0.03	-0.03	0.000	3.900	0.00	0.20	0.00
75	1:QZLokaal	Qw12	-0.03	-0.03	0.000	0.000	0.00	0.20	0.00
73	1:QZLokaal	Qw12	-0.03	-0.03	0.000	0.000	0.00	0.20	0.00
65	1:QZLokaal	Qw12	-0.03	-0.03	0.000	0.000	0.00	0.20	0.00
71	1:QZLokaal	Qw13	1.29	1.29	1.126	0.000	0.00	0.20	0.00
71	1:QZLokaal	Qw14	1.19	1.19	0.000	3.900	0.00	0.20	0.00
79	1:QZLokaal	Qw14	1.19	1.19	0.000	0.000	0.00	0.20	0.00
81	1:QZLokaal	Qw14	1.19	1.19	0.000	0.000	0.00	0.20	0.00
64	1:QZLokaal	Qw14	1.19	1.19	0.000	0.000	0.00	0.20	0.00
68	1:QZLokaal	Qw7	1.02	1.02	0.000	0.000	0.00	0.20	0.00
66	1:QZLokaal	Qw7	1.02	1.02	0.000	0.000	0.00	0.20	0.00
49	1:QZLokaal	Qw7	1.02	1.02	0.000	0.000	0.00	0.20	0.00
1	1:QZLokaal	Qw7	1.02	1.02	0.118	0.000	0.00	0.20	0.00

Onderdeel.....:

REACTIES

B.G:11 Wind van rechts overdruk A

Kn.	X	Z	M
1	99.11	92.90	
3	0.80	-32.20	
4	1.36	-12.31	
5	0.99	76.29	
7	120.66	22.46	
8	2.17	-133.89	
9	3.15	-20.97	
10	2.21	-31.79	
230.44			-39.52 : Som van de reacties
-230.44			39.52 : Som van de belastingen

BELASTINGEN

B.G:12 Wind van rechts onderdruk B

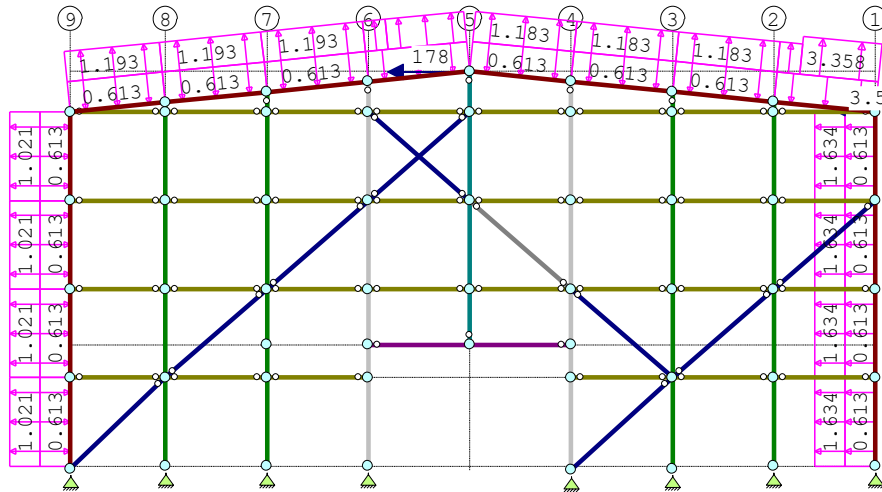

KNOOPBELASTINGEN

B.G:12 Wind van rechts onderdruk B

Last	Knoop	Richting	waarde	Ψ_0	Ψ_1	Ψ_2	Opm.
1	6	X	-178.000	0.00	0.20	0.00	*
2	18	X	-3.500	0.00	0.20	0.00	*

Opmerkingen

[*] Deze belasting is handmatig toegevoegd of gewijzigd.

STAAFBELASTINGEN

B.G:12 Wind van rechts onderdruk B

Staaftype	Index	q1/p/m	q2	A	B	Ψ_0	Ψ_1	Ψ_2
1:QZLokaal	Qw1	-0.61	-0.61	0.118	0.000	0.00	0.20	0.00
49:1:QZLokaal	Qw1	-0.61	-0.61	0.000	0.000	0.00	0.20	0.00
66:1:QZLokaal	Qw1	-0.61	-0.61	0.000	0.000	0.00	0.20	0.00
68:1:QZLokaal	Qw1	-0.61	-0.61	0.000	0.000	0.00	0.20	0.00
64:1:QZLokaal	Qw1	-0.61	-0.61	0.000	0.000	0.00	0.20	0.00
81:1:QZLokaal	Qw1	-0.61	-0.61	0.000	0.000	0.00	0.20	0.00
79:1:QZLokaal	Qw1	-0.61	-0.61	0.000	0.000	0.00	0.20	0.00
71:1:QZLokaal	Qw1	-0.61	-0.61	0.000	0.000	0.00	0.20	0.00
65:1:QZLokaal	Qw1	-0.61	-0.61	0.000	0.000	0.00	0.20	0.00
73:1:QZLokaal	Qw1	-0.61	-0.61	0.000	0.000	0.00	0.20	0.00
75:1:QZLokaal	Qw1	-0.61	-0.61	0.000	0.000	0.00	0.20	0.00
77:1:QZLokaal	Qw1	-0.61	-0.61	0.000	0.000	0.00	0.20	0.00
18:1:QZLokaal	Qw1	-0.61	-0.61	0.000	0.000	0.00	0.20	0.00
33:1:QZLokaal	Qw1	-0.61	-0.61	0.000	0.000	0.00	0.20	0.00
48:1:QZLokaal	Qw1	-0.61	-0.61	0.000	0.000	0.00	0.20	0.00
58:1:QZLokaal	Qw1	-0.61	-0.61	0.000	0.000	0.00	0.20	0.00
58:1:QZLokaal	Qw2	-1.63	-1.63	0.000	0.000	0.00	0.20	0.00
48:1:QZLokaal	Qw2	-1.63	-1.63	0.000	0.000	0.00	0.20	0.00
33:1:QZLokaal	Qw2	-1.63	-1.63	0.000	0.000	0.00	0.20	0.00
18:1:QZLokaal	Qw2	-1.63	-1.63	0.000	0.000	0.00	0.20	0.00
77:1:QZLokaal	Qw15	3.36	3.36	1.125	0.000	0.00	0.20	0.00

Onderdeel.....:

STAAFBELASTINGEN

B.G:12 Wind van rechts onderdruk B

Staaftype	Index	q1/p/m	q2	A	B	Ψ_0	Ψ_1	Ψ_2
77:1:QZLokaal	Qw16	1.18	1.18	0.000	3.900	0.00	0.20	0.00
75:1:QZLokaal	Qw16	1.18	1.18	0.000	0.000	0.00	0.20	0.00
73:1:QZLokaal	Qw16	1.18	1.18	0.000	0.000	0.00	0.20	0.00
65:1:QZLokaal	Qw16	1.18	1.18	0.000	0.000	0.00	0.20	0.00
71:1:QZLokaal	Qw13	1.29	1.29	1.126	0.000	0.00	0.20	0.00
71:1:QZLokaal	Qw14	1.19	1.19	0.000	3.900	0.00	0.20	0.00
79:1:QZLokaal	Qw14	1.19	1.19	0.000	0.000	0.00	0.20	0.00
81:1:QZLokaal	Qw14	1.19	1.19	0.000	0.000	0.00	0.20	0.00
64:1:QZLokaal	Qw14	1.19	1.19	0.000	0.000	0.00	0.20	0.00
68:1:QZLokaal	Qw7	1.02	1.02	0.000	0.000	0.00	0.20	0.00
66:1:QZLokaal	Qw7	1.02	1.02	0.000	0.000	0.00	0.20	0.00
49:1:QZLokaal	Qw7	1.02	1.02	0.000	0.000	0.00	0.20	0.00
1:1:QZLokaal	Qw7	1.02	1.02	0.118	0.000	0.00	0.20	0.00

REACTIES

B.G:12 Wind van rechts onderdruk B

Kn.	X	Z	M
1	93.14	91.31	
3	0.78	-24.13	
4	1.32	-6.22	
5	0.75	78.71	
7	121.69	24.09	
8	2.21	-131.00	
9	3.32	-27.02	
10	3.97	-37.38	
	227.18	-31.64	: Som van de reacties
	-227.18	31.64	: Som van de belastingen

BELASTINGEN

B.G:13 Wind van rechts overdruk B

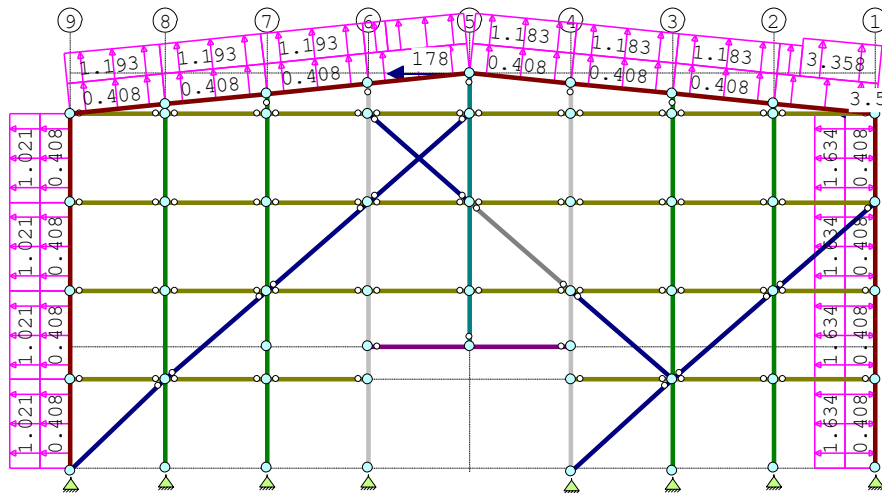

KNOOPBELASTINGEN

B.G:13 Wind van rechts overdruk B

Last	Knoop	Richting	waarde	Ψ_0	Ψ_1	Ψ_2	Opm.
1	6	X	-178.000	0.00	0.20	0.00	*
2	18	X	-3.500	0.00	0.20	0.00	*

Opmerkingen

[*] Deze belasting is handmatig toegevoegd of gewijzigd.

Onderdeel.....:

STAAFBELASTINGEN

B.G:13 Wind van rechts overdruk B

Staat	Type	Index	q1/p/m	q2	A	B	Ψ_0	Ψ_1	Ψ_2
1	1:QZLokaal	Qw8	0.41	0.41	0.118	0.000	0.00	0.20	0.00
49	1:QZLokaal	Qw8	0.41	0.41	0.000	0.000	0.00	0.20	0.00
66	1:QZLokaal	Qw8	0.41	0.41	0.000	0.000	0.00	0.20	0.00
68	1:QZLokaal	Qw8	0.41	0.41	0.000	0.000	0.00	0.20	0.00
64	1:QZLokaal	Qw8	0.41	0.41	0.000	0.000	0.00	0.20	0.00
81	1:QZLokaal	Qw8	0.41	0.41	0.000	0.000	0.00	0.20	0.00
79	1:QZLokaal	Qw8	0.41	0.41	0.000	0.000	0.00	0.20	0.00
71	1:QZLokaal	Qw8	0.41	0.41	0.000	0.000	0.00	0.20	0.00
65	1:QZLokaal	Qw8	0.41	0.41	0.000	0.000	0.00	0.20	0.00
73	1:QZLokaal	Qw8	0.41	0.41	0.000	0.000	0.00	0.20	0.00
75	1:QZLokaal	Qw8	0.41	0.41	0.000	0.000	0.00	0.20	0.00
77	1:QZLokaal	Qw8	0.41	0.41	0.000	0.000	0.00	0.20	0.00
18	1:QZLokaal	Qw8	0.41	0.41	0.000	0.000	0.00	0.20	0.00
33	1:QZLokaal	Qw8	0.41	0.41	0.000	0.000	0.00	0.20	0.00
48	1:QZLokaal	Qw8	0.41	0.41	0.000	0.000	0.00	0.20	0.00
58	1:QZLokaal	Qw8	0.41	0.41	0.000	0.000	0.00	0.20	0.00
58	1:QZLokaal	Qw2	-1.63	-1.63	0.000	0.000	0.00	0.20	0.00
48	1:QZLokaal	Qw2	-1.63	-1.63	0.000	0.000	0.00	0.20	0.00
33	1:QZLokaal	Qw2	-1.63	-1.63	0.000	0.000	0.00	0.20	0.00
18	1:QZLokaal	Qw2	-1.63	-1.63	0.000	0.000	0.00	0.20	0.00
77	1:QZLokaal	Qw15	3.36	3.36	1.125	0.000	0.00	0.20	0.00
77	1:QZLokaal	Qw16	1.18	1.18	0.000	3.900	0.00	0.20	0.00
75	1:QZLokaal	Qw16	1.18	1.18	0.000	0.000	0.00	0.20	0.00
73	1:QZLokaal	Qw16	1.18	1.18	0.000	0.000	0.00	0.20	0.00
65	1:QZLokaal	Qw16	1.18	1.18	0.000	0.000	0.00	0.20	0.00
71	1:QZLokaal	Qw13	1.29	1.29	1.126	0.000	0.00	0.20	0.00
71	1:QZLokaal	Qw14	1.19	1.19	0.000	3.900	0.00	0.20	0.00
79	1:QZLokaal	Qw14	1.19	1.19	0.000	0.000	0.00	0.20	0.00
81	1:QZLokaal	Qw14	1.19	1.19	0.000	0.000	0.00	0.20	0.00
64	1:QZLokaal	Qw14	1.19	1.19	0.000	0.000	0.00	0.20	0.00
68	1:QZLokaal	Qw7	1.02	1.02	0.000	0.000	0.00	0.20	0.00
66	1:QZLokaal	Qw7	1.02	1.02	0.000	0.000	0.00	0.20	0.00
49	1:QZLokaal	Qw7	1.02	1.02	0.000	0.000	0.00	0.20	0.00
1	1:QZLokaal	Qw7	1.02	1.02	0.118	0.000	0.00	0.20	0.00

REACTIES

B.G:13 Wind van rechts overdruk B

Kn.	X	Z	M
1	97.78	91.57	
3	0.79	-32.06	
4	1.36	-12.57	
5	0.98	74.00	
7	118.81	14.89	
8	2.14	-138.13	
9	3.12	-31.04	
10	2.19	-38.85	

227.18 : Som van de reacties
 -227.18 : Som van de belastingen

Onderdeel.....:

BELASTINGEN

B.G:14 Wind van rechts onderdruk C

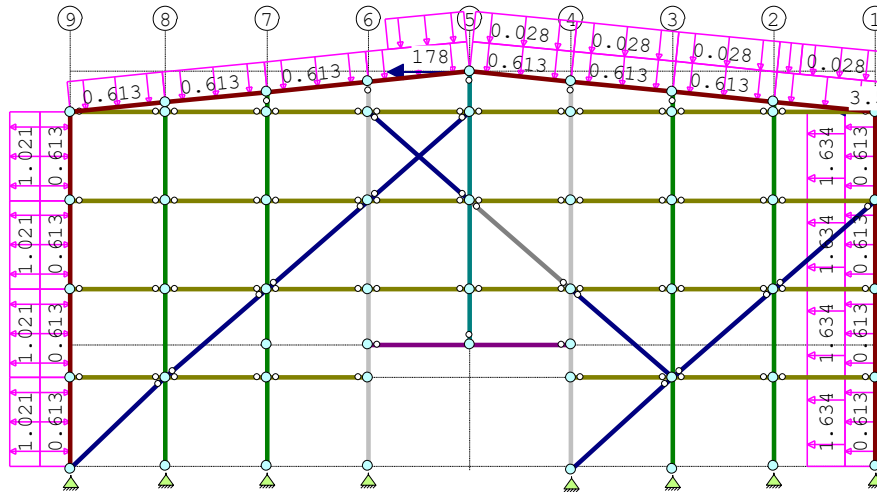

KNOOPBELASTINGEN

B.G:14 Wind van rechts onderdruk C

Last	Knoop	Richting	waarde	Ψ_0	Ψ_1	Ψ_2	Opm.
1	6	X	-178.000	0.00	0.20	0.00	*
2	18	X	-3.500	0.00	0.20	0.00	*

Opmerkingen

[*] Deze belasting is handmatig toegevoegd of gewijzigd.

STAAFBELASTINGEN

B.G:14 Wind van rechts onderdruk C

Staat	Type	Index	q1/p/m	q2	A	B	Ψ_0	Ψ_1	Ψ_2
1	1:QZLokaal	Qw1	-0.61	-0.61	0.118	0.000	0.00	0.20	0.00
49	1:QZLokaal	Qw1	-0.61	-0.61	0.000	0.000	0.00	0.20	0.00
66	1:QZLokaal	Qw1	-0.61	-0.61	0.000	0.000	0.00	0.20	0.00
68	1:QZLokaal	Qw1	-0.61	-0.61	0.000	0.000	0.00	0.20	0.00
64	1:QZLokaal	Qw1	-0.61	-0.61	0.000	0.000	0.00	0.20	0.00
81	1:QZLokaal	Qw1	-0.61	-0.61	0.000	0.000	0.00	0.20	0.00
79	1:QZLokaal	Qw1	-0.61	-0.61	0.000	0.000	0.00	0.20	0.00
71	1:QZLokaal	Qw1	-0.61	-0.61	0.000	0.000	0.00	0.20	0.00
65	1:QZLokaal	Qw1	-0.61	-0.61	0.000	0.000	0.00	0.20	0.00
73	1:QZLokaal	Qw1	-0.61	-0.61	0.000	0.000	0.00	0.20	0.00
75	1:QZLokaal	Qw1	-0.61	-0.61	0.000	0.000	0.00	0.20	0.00
77	1:QZLokaal	Qw1	-0.61	-0.61	0.000	0.000	0.00	0.20	0.00
18	1:QZLokaal	Qw1	-0.61	-0.61	0.000	0.000	0.00	0.20	0.00
33	1:QZLokaal	Qw1	-0.61	-0.61	0.000	0.000	0.00	0.20	0.00
48	1:QZLokaal	Qw1	-0.61	-0.61	0.000	0.000	0.00	0.20	0.00
58	1:QZLokaal	Qw1	-0.61	-0.61	0.000	0.000	0.00	0.20	0.00
58	1:QZLokaal	Qw2	-1.63	-1.63	0.000	0.000	0.00	0.20	0.00
48	1:QZLokaal	Qw2	-1.63	-1.63	0.000	0.000	0.00	0.20	0.00
33	1:QZLokaal	Qw2	-1.63	-1.63	0.000	0.000	0.00	0.20	0.00
18	1:QZLokaal	Qw2	-1.63	-1.63	0.000	0.000	0.00	0.20	0.00
77	1:QZLokaal	Qw11	-0.03	-0.03	1.125	0.000	0.00	0.20	0.00
77	1:QZLokaal	Qw12	-0.03	-0.03	0.000	3.900	0.00	0.20	0.00
75	1:QZLokaal	Qw12	-0.03	-0.03	0.000	0.000	0.00	0.20	0.00
73	1:QZLokaal	Qw12	-0.03	-0.03	0.000	0.000	0.00	0.20	0.00
65	1:QZLokaal	Qw12	-0.03	-0.03	0.000	0.000	0.00	0.20	0.00
71	1:QZLokaal	Qw18	-0.38	-0.38	1.126	0.000	0.00	0.20	0.00
68	1:QZLokaal	Qw7	1.02	1.02	0.000	0.000	0.00	0.20	0.00
66	1:QZLokaal	Qw7	1.02	1.02	0.000	0.000	0.00	0.20	0.00
49	1:QZLokaal	Qw7	1.02	1.02	0.000	0.000	0.00	0.20	0.00
1	1:QZLokaal	Qw7	1.02	1.02	0.118	0.000	0.00	0.20	0.00

Onderdeel.....:

REACTIES

B.G:14 Wind van rechts onderdruk C

Kn.	X	Z	M
1	93.89	94.45	
3	0.76	-17.45	
4	1.28	-0.03	
5	0.74	87.30	
7	121.71	32.92	
8	2.21	-124.09	
9	3.30	-16.67	
10	3.98	-30.08	
227.87		26.35	: Som van de reacties
-227.87		-26.35	: Som van de belastingen

BELASTINGEN

B.G:15 Wind van rechts overdruk C

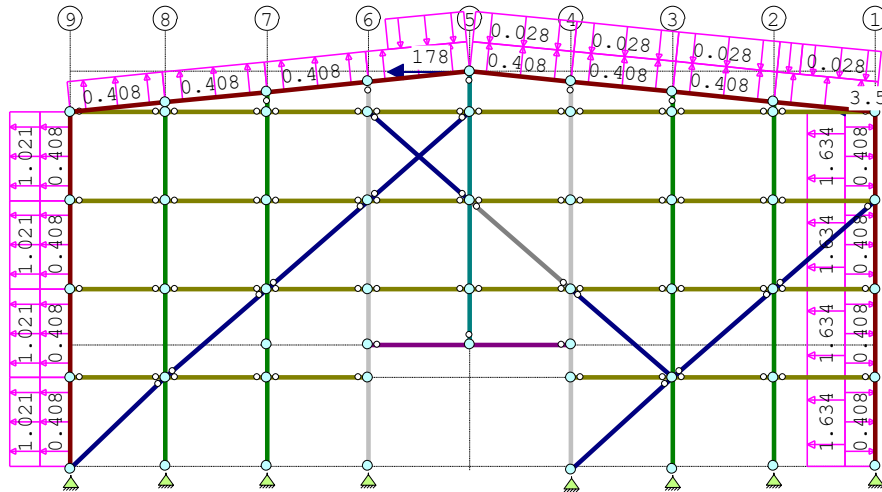

KNOOPBELASTINGEN

B.G:15 Wind van rechts overdruk C

Last	Knoop	Richting	waarde	Ψ_0	Ψ_1	Ψ_2	Opm.
1	6	X	-178.000	0.00	0.20	0.00	*
2	18	X	-3.500	0.00	0.20	0.00	*

Opmerkingen

[*] Deze belasting is handmatig toegevoegd of gewijzigd.

STAAFBELASTINGEN

B.G:15 Wind van rechts overdruk C

Staatf	Type	Index	q1/p/m	q2	A	B	Ψ_0	Ψ_1	Ψ_2
1	1:QZLokaal	Qw8	0.41	0.41	0.118	0.000	0.00	0.20	0.00
49	1:QZLokaal	Qw8	0.41	0.41	0.000	0.000	0.00	0.20	0.00
66	1:QZLokaal	Qw8	0.41	0.41	0.000	0.000	0.00	0.20	0.00
68	1:QZLokaal	Qw8	0.41	0.41	0.000	0.000	0.00	0.20	0.00
64	1:QZLokaal	Qw8	0.41	0.41	0.000	0.000	0.00	0.20	0.00
81	1:QZLokaal	Qw8	0.41	0.41	0.000	0.000	0.00	0.20	0.00
79	1:QZLokaal	Qw8	0.41	0.41	0.000	0.000	0.00	0.20	0.00
71	1:QZLokaal	Qw8	0.41	0.41	0.000	0.000	0.00	0.20	0.00
65	1:QZLokaal	Qw8	0.41	0.41	0.000	0.000	0.00	0.20	0.00
73	1:QZLokaal	Qw8	0.41	0.41	0.000	0.000	0.00	0.20	0.00
75	1:QZLokaal	Qw8	0.41	0.41	0.000	0.000	0.00	0.20	0.00
77	1:QZLokaal	Qw8	0.41	0.41	0.000	0.000	0.00	0.20	0.00
18	1:QZLokaal	Qw8	0.41	0.41	0.000	0.000	0.00	0.20	0.00
33	1:QZLokaal	Qw8	0.41	0.41	0.000	0.000	0.00	0.20	0.00
48	1:QZLokaal	Qw8	0.41	0.41	0.000	0.000	0.00	0.20	0.00
58	1:QZLokaal	Qw8	0.41	0.41	0.000	0.000	0.00	0.20	0.00
58	1:QZLokaal	Qw2	-1.63	-1.63	0.000	0.000	0.00	0.20	0.00
48	1:QZLokaal	Qw2	-1.63	-1.63	0.000	0.000	0.00	0.20	0.00
33	1:QZLokaal	Qw2	-1.63	-1.63	0.000	0.000	0.00	0.20	0.00
18	1:QZLokaal	Qw2	-1.63	-1.63	0.000	0.000	0.00	0.20	0.00
77	1:QZLokaal	Qw11	-0.03	-0.03	1.125	0.000	0.00	0.20	0.00

Onderdeel.....:

STAAFBELASTINGEN

B.G:15 Wind van rechts overdruk C

Staatf	Type	Index	q1/p/m	q2	A	B	Ψ_0	Ψ_1	Ψ_2
77	1:QZLokaal	Qw12	-0.03	-0.03	0.000	3.900	0.00	0.20	0.00
75	1:QZLokaal	Qw12	-0.03	-0.03	0.000	0.000	0.00	0.20	0.00
73	1:QZLokaal	Qw12	-0.03	-0.03	0.000	0.000	0.00	0.20	0.00
65	1:QZLokaal	Qw12	-0.03	-0.03	0.000	0.000	0.00	0.20	0.00
71	1:QZLokaal	Qw18	-0.38	-0.38	1.126	0.000	0.00	0.20	0.00
68	1:QZLokaal	Qw7	1.02	1.02	0.000	0.000	0.00	0.20	0.00
66	1:QZLokaal	Qw7	1.02	1.02	0.000	0.000	0.00	0.20	0.00
49	1:QZLokaal	Qw7	1.02	1.02	0.000	0.000	0.00	0.20	0.00
1	1:QZLokaal	Qw7	1.02	1.02	0.118	0.000	0.00	0.20	0.00

REACTIES

B.G:15 Wind van rechts overdruk C

Kn.	X	Z	M
1	98.54	94.72	
3	0.78	-25.38	
4	1.32	-6.38	
5	0.97	82.59	
7	118.83	23.72	
8	2.14	-131.22	
9	3.09	-20.69	
10	2.21	-31.55	
227.87			-14.19 : Som van de reacties
-227.87			14.19 : Som van de belastingen

BELASTINGEN

B.G:16 Wind van rechts onderdruk D

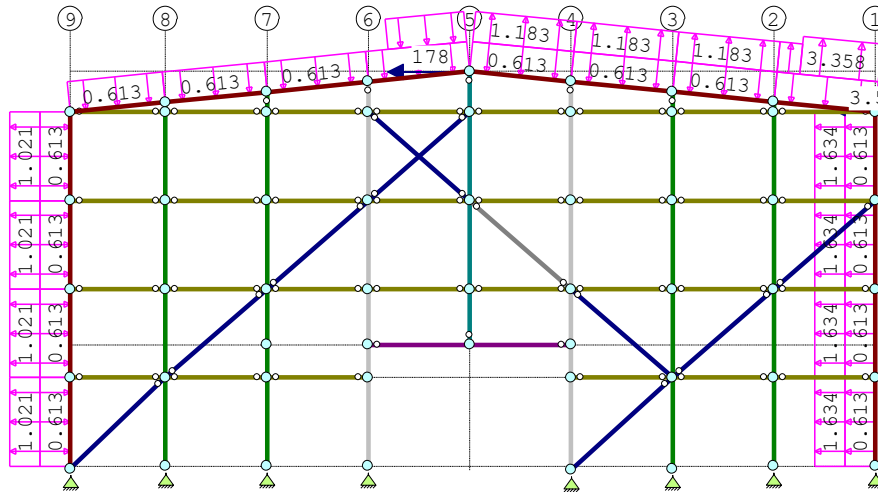

KNOOPBELASTINGEN

B.G:16 Wind van rechts onderdruk D

Last	Knoop	Richting	waarde	Ψ_0	Ψ_1	Ψ_2	Opm.
1	6	X	-178.000	0.00	0.20	0.00	*
2	18	X	-3.500	0.00	0.20	0.00	*

Opmerkingen

[*] Deze belasting is handmatig toegevoegd of gewijzigd.

STAAFBELASTINGEN

B.G:16 Wind van rechts onderdruk D

Staaftype	Type	Index	q1/p/m	q2	A	B	Ψ_0	Ψ_1	Ψ_2
1	1:QZLokaal	Qw1	-0.61	-0.61	0.118	0.000	0.00	0.20	0.00
49	1:QZLokaal	Qw1	-0.61	-0.61	0.000	0.000	0.00	0.20	0.00
66	1:QZLokaal	Qw1	-0.61	-0.61	0.000	0.000	0.00	0.20	0.00
68	1:QZLokaal	Qw1	-0.61	-0.61	0.000	0.000	0.00	0.20	0.00
64	1:QZLokaal	Qw1	-0.61	-0.61	0.000	0.000	0.00	0.20	0.00
81	1:QZLokaal	Qw1	-0.61	-0.61	0.000	0.000	0.00	0.20	0.00
79	1:QZLokaal	Qw1	-0.61	-0.61	0.000	0.000	0.00	0.20	0.00
71	1:QZLokaal	Qw1	-0.61	-0.61	0.000	0.000	0.00	0.20	0.00
65	1:QZLokaal	Qw1	-0.61	-0.61	0.000	0.000	0.00	0.20	0.00

Onderdeel.....:

STAAFBELASTINGEN

B.G:16 Wind van rechts onderdruk D

Staaftype	Type	Index	q1/p/m	q2	A	B	Ψ_0	Ψ_1	Ψ_2
73	1:QZLokaal	Qw1	-0.61	-0.61	0.000	0.000	0.00	0.20	0.00
75	1:QZLokaal	Qw1	-0.61	-0.61	0.000	0.000	0.00	0.20	0.00
77	1:QZLokaal	Qw1	-0.61	-0.61	0.000	0.000	0.00	0.20	0.00
18	1:QZLokaal	Qw1	-0.61	-0.61	0.000	0.000	0.00	0.20	0.00
33	1:QZLokaal	Qw1	-0.61	-0.61	0.000	0.000	0.00	0.20	0.00
48	1:QZLokaal	Qw1	-0.61	-0.61	0.000	0.000	0.00	0.20	0.00
58	1:QZLokaal	Qw1	-0.61	-0.61	0.000	0.000	0.00	0.20	0.00
58	1:QZLokaal	Qw2	-1.63	-1.63	0.000	0.000	0.00	0.20	0.00
48	1:QZLokaal	Qw2	-1.63	-1.63	0.000	0.000	0.00	0.20	0.00
33	1:QZLokaal	Qw2	-1.63	-1.63	0.000	0.000	0.00	0.20	0.00
18	1:QZLokaal	Qw2	-1.63	-1.63	0.000	0.000	0.00	0.20	0.00
77	1:QZLokaal	Qw15	3.36	3.36	1.125	0.000	0.00	0.20	0.00
77	1:QZLokaal	Qw16	1.18	1.18	0.000	3.900	0.00	0.20	0.00
75	1:QZLokaal	Qw16	1.18	1.18	0.000	0.000	0.00	0.20	0.00
73	1:QZLokaal	Qw16	1.18	1.18	0.000	0.000	0.00	0.20	0.00
65	1:QZLokaal	Qw16	1.18	1.18	0.000	0.000	0.00	0.20	0.00
71	1:QZLokaal	Qw18	-0.38	-0.38	1.126	0.000	0.00	0.20	0.00
68	1:QZLokaal	Qw7	1.02	1.02	0.000	0.000	0.00	0.20	0.00
66	1:QZLokaal	Qw7	1.02	1.02	0.000	0.000	0.00	0.20	0.00
49	1:QZLokaal	Qw7	1.02	1.02	0.000	0.000	0.00	0.20	0.00
1	1:QZLokaal	Qw7	1.02	1.02	0.118	0.000	0.00	0.20	0.00

REACTIES

B.G:16 Wind van rechts onderdruk D

Kn.	X	Z	M
1	92.56	93.13	
3	0.76	-17.31	
4	1.28	-0.29	
5	0.73	85.01	
7	119.86	25.35	
8	2.18	-128.32	
9	3.27	-26.74	
10	3.97	-37.14	
224.61		-6.31	: Som van de reacties
-224.61		6.31	: Som van de belastingen

BELASTINGEN

B.G:17 Wind van rechts overdruk D

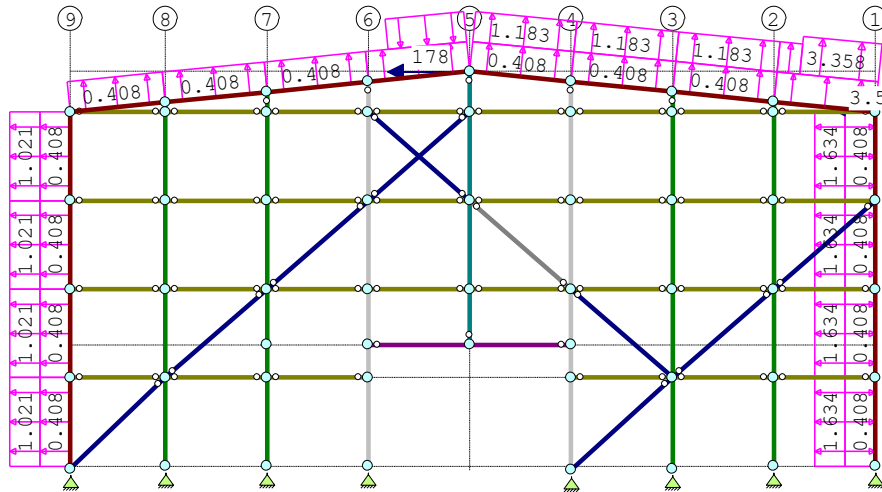

Onderdeel.....:

KNOOPBELASTINGEN

B.G:17 Wind van rechts overdruk D

Last	Knoop	Richting	waarde	Ψ_0	Ψ_1	Ψ_2	Opm.
1	6	X	-178.000	0.00	0.20	0.00	*
2	18	X	-3.500	0.00	0.20	0.00	*

Opmerkingen

[*] Deze belasting is handmatig toegevoegd of gewijzigd.

STAAFBELASTINGEN

B.G:17 Wind van rechts overdruk D

Staat	Type	Index	q1/p/m	q2	A	B	Ψ_0	Ψ_1	Ψ_2
1	1:QZLokaal	Qw8	0.41	0.41	0.118	0.000	0.00	0.20	0.00
49	1:QZLokaal	Qw8	0.41	0.41	0.000	0.000	0.00	0.20	0.00
66	1:QZLokaal	Qw8	0.41	0.41	0.000	0.000	0.00	0.20	0.00
68	1:QZLokaal	Qw8	0.41	0.41	0.000	0.000	0.00	0.20	0.00
64	1:QZLokaal	Qw8	0.41	0.41	0.000	0.000	0.00	0.20	0.00
81	1:QZLokaal	Qw8	0.41	0.41	0.000	0.000	0.00	0.20	0.00
79	1:QZLokaal	Qw8	0.41	0.41	0.000	0.000	0.00	0.20	0.00
71	1:QZLokaal	Qw8	0.41	0.41	0.000	0.000	0.00	0.20	0.00
65	1:QZLokaal	Qw8	0.41	0.41	0.000	0.000	0.00	0.20	0.00
73	1:QZLokaal	Qw8	0.41	0.41	0.000	0.000	0.00	0.20	0.00
75	1:QZLokaal	Qw8	0.41	0.41	0.000	0.000	0.00	0.20	0.00
77	1:QZLokaal	Qw8	0.41	0.41	0.000	0.000	0.00	0.20	0.00
18	1:QZLokaal	Qw8	0.41	0.41	0.000	0.000	0.00	0.20	0.00
33	1:QZLokaal	Qw8	0.41	0.41	0.000	0.000	0.00	0.20	0.00
48	1:QZLokaal	Qw8	0.41	0.41	0.000	0.000	0.00	0.20	0.00
58	1:QZLokaal	Qw8	0.41	0.41	0.000	0.000	0.00	0.20	0.00
58	1:QZLokaal	Qw2	-1.63	-1.63	0.000	0.000	0.00	0.20	0.00
48	1:QZLokaal	Qw2	-1.63	-1.63	0.000	0.000	0.00	0.20	0.00
33	1:QZLokaal	Qw2	-1.63	-1.63	0.000	0.000	0.00	0.20	0.00
18	1:QZLokaal	Qw2	-1.63	-1.63	0.000	0.000	0.00	0.20	0.00
77	1:QZLokaal	Qw15	3.36	3.36	1.125	0.000	0.00	0.20	0.00
77	1:QZLokaal	Qw16	1.18	1.18	0.000	3.900	0.00	0.20	0.00
75	1:QZLokaal	Qw16	1.18	1.18	0.000	0.000	0.00	0.20	0.00
73	1:QZLokaal	Qw16	1.18	1.18	0.000	0.000	0.00	0.20	0.00
65	1:QZLokaal	Qw16	1.18	1.18	0.000	0.000	0.00	0.20	0.00
71	1:QZLokaal	Qw18	-0.38	-0.38	1.126	0.000	0.00	0.20	0.00
68	1:QZLokaal	Qw7	1.02	1.02	0.000	0.000	0.00	0.20	0.00
66	1:QZLokaal	Qw7	1.02	1.02	0.000	0.000	0.00	0.20	0.00
49	1:QZLokaal	Qw7	1.02	1.02	0.000	0.000	0.00	0.20	0.00
1	1:QZLokaal	Qw7	1.02	1.02	0.118	0.000	0.00	0.20	0.00

REACTIES

B.G:17 Wind van rechts overdruk D

Kn.	X	Z	M
1	97.21	93.40	
3	0.77	-25.24	
4	1.31	-6.64	
5	0.96	80.29	
7	116.97	16.15	
8	2.12	-135.45	
9	3.07	-30.76	
10	2.19	-38.60	
	224.61	-46.85	: Som van de reacties
	-224.61	46.85	: Som van de belastingen

Onderdeel.....:

BELASTINGEN

B.G:18 SNEEUW

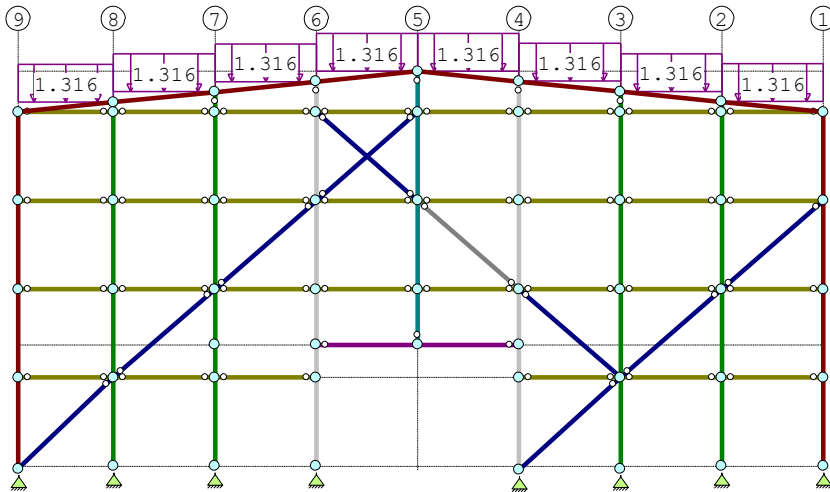

STAAFBELASTINGEN

B.G:18 SNEUW

Staaftype	Type	q1/p/m	q2	A	B	Ψ_0	Ψ_1	Ψ_2
64	3:QZgeProj.	-1.32	-1.32	0.000	0.000	1.00	0.90	0.80
81	3:QZgeProj.	-1.32	-1.32	0.000	0.000	1.00	0.90	0.80
79	3:QZgeProj.	-1.32	-1.32	0.000	0.000	1.00	0.90	0.80
71	3:QZgeProj.	-1.32	-1.32	0.000	0.000	1.00	0.90	0.80
65	3:QZgeProj.	-1.32	-1.32	0.000	0.000	1.00	0.90	0.80
73	3:QZgeProj.	-1.32	-1.32	0.000	0.000	1.00	0.90	0.80
75	3:QZgeProj.	-1.32	-1.32	0.000	0.000	1.00	0.90	0.80
77	3:QZgeProj.	-1.32	-1.32	0.000	0.000	1.00	0.90	0.80

REACTIES

B.G:18 SNEUW

Kn.	X	Z	M
1	0.52	3.16	
3	-0.02	7.30	
4	-0.05	6.81	
5	-0.01	7.80	
7	-0.40	9.45	
8	-0.01	8.04	
9	-0.03	6.92	
10	0.00	2.77	

0.00 52.25 : Som van de reacties
 0.00 -52.25 : Som van de belastingen

Onderdeel....:

BELASTINGEN

B.G:19 Knik

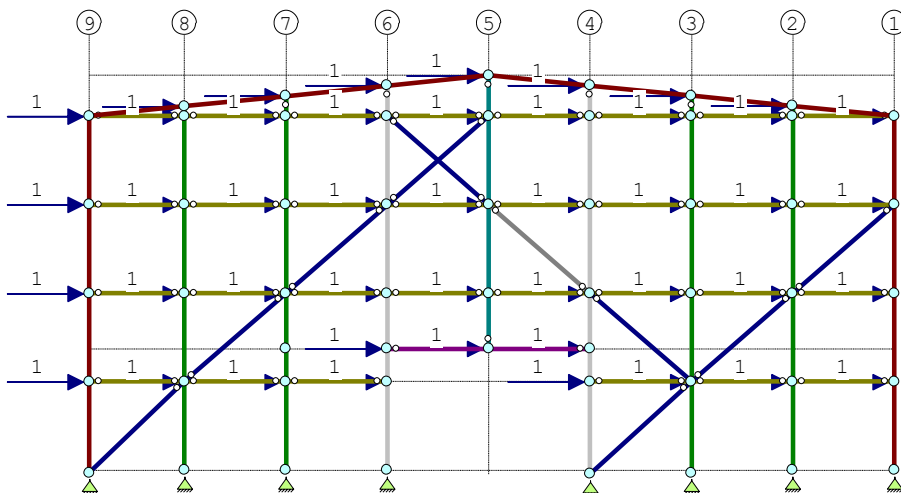

KNOOPBELASTINGEN

B.G:19 Knik

Last	Knoop	Richting	waarde	Ψ_0	Ψ_1	Ψ_2
1	2	X	1.000			
2	6	X	1.000			
3	11	X	1.000			
4	12	X	1.000			
5	13	X	1.000			
6	14	X	1.000			
7	15	X	1.000			

8	16 X	1.000
9	17 X	1.000
10	18 X	1.000
11	19 X	1.000
12	20 X	1.000
13	21 X	1.000
14	22 X	1.000
15	23 X	1.000
16	24 X	1.000
17	25 X	1.000
18	26 X	1.000
19	27 X	1.000
20	28 X	1.000
21	29 X	1.000
22	30 X	1.000
23	31 X	1.000
24	32 X	1.000
25	33 X	1.000
26	34 X	1.000
27	35 X	1.000
28	36 X	1.000
29	37 X	1.000
30	38 X	1.000
31	39 X	1.000
32	40 X	1.000
33	41 X	1.000
34	42 X	1.000
35	44 X	1.000
36	45 X	1.000
37	46 X	1.000
38	47 X	1.000
39	48 X	1.000
40	49 X	1.000
41	50 X	1.000
42	51 X	1.000

Onderdeel....:

KNOOPBELASTINGEN

B.G:19 Knik

Last	Knoop	Richting	waarde	Ψ_0	Ψ_1	Ψ_2
43	52	X	1.000			
44	53	X	1.000			
45	54	X	1.000			

REACTIES

B.G:19 Knik

Kn.	X	Z	M
1	-19.57	-18.88	
3	-0.14	5.88	
4	-0.34	4.65	
5	-0.40	-4.47	
7	-23.44	-18.02	
8	-0.45	21.79	
9	-0.64	4.81	
10	-0.02	4.24	
	-45.00	0.00	: Som van de reacties
	45.00	0.00	: Som van de belastingen

BELASTINGCOMBINATIES

BC	Type			
1	Fund.	1.35	$G_{k,1}$	
2	Fund.	0.90	$G_{k,1}$	
3	Fund.	1.35	$G_{k,1}$	+ 1.50 Ψ_0 $Q_{k,1,8}$
4	Fund.	1.20	$G_{k,1}$	+ 1.50 $Q_{k,2}$
5	Fund.	1.20	$G_{k,1}$	+ 1.50 $Q_{k,3}$
6	Fund.	1.20	$G_{k,1}$	+ 1.50 $Q_{k,4}$
7	Fund.	1.20	$G_{k,1}$	+ 1.50 $Q_{k,5}$
8	Fund.	1.20	$G_{k,1}$	+ 1.50 $Q_{k,6}$
9	Fund.	1.20	$G_{k,1}$	+ 1.50 $Q_{k,7}$
10	Fund.	1.20	$G_{k,1}$	+ 1.50 $Q_{k,8}$
11	Fund.	1.20	$G_{k,1}$	+ 1.50 $Q_{k,9}$
12	Fund.	1.20	$G_{k,1}$	+ 1.50 $Q_{k,10}$
13	Fund.	1.20	$G_{k,1}$	+ 1.50 $Q_{k,11}$
14	Fund.	1.20	$G_{k,1}$	+ 1.50 $Q_{k,12}$
15	Fund.	1.20	$G_{k,1}$	+ 1.50 $Q_{k,13}$
16	Fund.	1.20	$G_{k,1}$	+ 1.50 $Q_{k,14}$
17	Fund.	1.20	$G_{k,1}$	+ 1.50 $Q_{k,15}$
18	Fund.	1.20	$G_{k,1}$	+ 1.50 $Q_{k,16}$
19	Fund.	1.20	$G_{k,1}$	+ 1.50 $Q_{k,17}$
20	Fund.	1.20	$G_{k,1}$	+ 1.50 $Q_{k,18}$
21	Fund.	0.90	$G_{k,1}$	+ 1.50 $Q_{k,2}$
22	Fund.	0.90	$G_{k,1}$	+ 1.50 $Q_{k,3}$
23	Fund.	0.90	$G_{k,1}$	+ 1.50 $Q_{k,4}$
24	Fund.	0.90	$G_{k,1}$	+ 1.50 $Q_{k,5}$
25	Fund.	0.90	$G_{k,1}$	+ 1.50 $Q_{k,6}$

26 Fund.	0.90	$G_{k,1}$	+	1.50	$Q_{k,7}$	
27 Fund.	0.90	$G_{k,1}$	+	1.50	$Q_{k,8}$	
28 Fund.	0.90	$G_{k,1}$	+	1.50	$Q_{k,9}$	
29 Fund.	0.90	$G_{k,1}$	+	1.50	$Q_{k,10}$	
30 Fund.	0.90	$G_{k,1}$	+	1.50	$Q_{k,11}$	
31 Fund.	0.90	$G_{k,1}$	+	1.50	$Q_{k,12}$	
32 Fund.	0.90	$G_{k,1}$	+	1.50	$Q_{k,13}$	
33 Fund.	0.90	$G_{k,1}$	+	1.50	$Q_{k,14}$	
34 Fund.	0.90	$G_{k,1}$	+	1.50	$Q_{k,15}$	
35 Fund.	0.90	$G_{k,1}$	+	1.50	$Q_{k,16}$	
36 Fund.	0.90	$G_{k,1}$	+	1.50	$Q_{k,17}$	
37 Fund.	0.90	$G_{k,1}$	+	1.50	$\Psi_0 Q_{k,18}$	
38 Fund.	0.90	$G_{k,1}$	+	1.50	$Q_{k,18}$	
39 Fund.	1.20	$G_{k,1}$	+	1.50	$Q_{k,2}$	+ 1.50 $\Psi_0 Q_{k,18}$

Onderdeel.....:

BELASTINGCOMBINATIES

BC	Type					
40 Fund.	1.20	$G_{k,1}$	+	1.50	$Q_{k,3}$	+ 1.50 $\Psi_0 Q_{k,18}$
41 Fund.	1.20	$G_{k,1}$	+	1.50	$Q_{k,4}$	+ 1.50 $\Psi_0 Q_{k,18}$
42 Fund.	1.20	$G_{k,1}$	+	1.50	$Q_{k,5}$	+ 1.50 $\Psi_0 Q_{k,18}$
43 Fund.	1.20	$G_{k,1}$	+	1.50	$Q_{k,6}$	+ 1.50 $\Psi_0 Q_{k,18}$
44 Fund.	1.20	$G_{k,1}$	+	1.50	$Q_{k,7}$	+ 1.50 $\Psi_0 Q_{k,18}$
45 Fund.	1.20	$G_{k,1}$	+	1.50	$Q_{k,8}$	+ 1.50 $\Psi_0 Q_{k,18}$
46 Fund.	1.20	$G_{k,1}$	+	1.50	$Q_{k,9}$	+ 1.50 $\Psi_0 Q_{k,18}$
47 Fund.	1.20	$G_{k,1}$	+	1.50	$Q_{k,10}$	+ 1.50 $\Psi_0 Q_{k,18}$
48 Fund.	1.20	$G_{k,1}$	+	1.50	$Q_{k,11}$	+ 1.50 $\Psi_0 Q_{k,18}$
49 Fund.	1.20	$G_{k,1}$	+	1.50	$Q_{k,12}$	+ 1.50 $\Psi_0 Q_{k,18}$
50 Fund.	1.20	$G_{k,1}$	+	1.50	$Q_{k,13}$	+ 1.50 $\Psi_0 Q_{k,18}$
51 Fund.	1.20	$G_{k,1}$	+	1.50	$Q_{k,14}$	+ 1.50 $\Psi_0 Q_{k,18}$
52 Fund.	1.20	$G_{k,1}$	+	1.50	$Q_{k,15}$	+ 1.50 $\Psi_0 Q_{k,18}$
53 Fund.	1.20	$G_{k,1}$	+	1.50	$Q_{k,16}$	+ 1.50 $\Psi_0 Q_{k,18}$
54 Fund.	1.20	$G_{k,1}$	+	1.50	$Q_{k,17}$	+ 1.50 $\Psi_0 Q_{k,18}$
55 Fund.	0.90	$G_{k,1}$	+	1.50	$Q_{k,2}$	+ 1.50 $\Psi_0 Q_{k,18}$
56 Fund.	0.90	$G_{k,1}$	+	1.50	$Q_{k,3}$	+ 1.50 $\Psi_0 Q_{k,18}$
57 Fund.	0.90	$G_{k,1}$	+	1.50	$Q_{k,4}$	+ 1.50 $\Psi_0 Q_{k,18}$
58 Fund.	0.90	$G_{k,1}$	+	1.50	$Q_{k,5}$	+ 1.50 $\Psi_0 Q_{k,18}$
59 Fund.	0.90	$G_{k,1}$	+	1.50	$Q_{k,6}$	+ 1.50 $\Psi_0 Q_{k,18}$
60 Fund.	0.90	$G_{k,1}$	+	1.50	$Q_{k,7}$	+ 1.50 $\Psi_0 Q_{k,18}$
61 Fund.	0.90	$G_{k,1}$	+	1.50	$Q_{k,8}$	+ 1.50 $\Psi_0 Q_{k,18}$
62 Fund.	0.90	$G_{k,1}$	+	1.50	$Q_{k,9}$	+ 1.50 $\Psi_0 Q_{k,18}$
63 Fund.	0.90	$G_{k,1}$	+	1.50	$Q_{k,10}$	+ 1.50 $\Psi_0 Q_{k,18}$
64 Fund.	0.90	$G_{k,1}$	+	1.50	$Q_{k,11}$	+ 1.50 $\Psi_0 Q_{k,18}$
65 Fund.	0.90	$G_{k,1}$	+	1.50	$Q_{k,12}$	+ 1.50 $\Psi_0 Q_{k,18}$
66 Fund.	0.90	$G_{k,1}$	+	1.50	$Q_{k,13}$	+ 1.50 $\Psi_0 Q_{k,18}$
67 Fund.	0.90	$G_{k,1}$	+	1.50	$Q_{k,14}$	+ 1.50 $\Psi_0 Q_{k,18}$
68 Fund.	0.90	$G_{k,1}$	+	1.50	$Q_{k,15}$	+ 1.50 $\Psi_0 Q_{k,18}$
69 Fund.	0.90	$G_{k,1}$	+	1.50	$Q_{k,16}$	+ 1.50 $\Psi_0 Q_{k,18}$
70 Fund.	0.90	$G_{k,1}$	+	1.50	$Q_{k,17}$	+ 1.50 $\Psi_0 Q_{k,18}$
71 Kar.	1.00	$G_{k,1}$	+	1.00	$Q_{k,2}$	
72 Kar.	1.00	$G_{k,1}$	+	1.00	$Q_{k,3}$	
73 Kar.	1.00	$G_{k,1}$	+	1.00	$Q_{k,4}$	
74 Kar.	1.00	$G_{k,1}$	+	1.00	$Q_{k,5}$	
75 Kar.	1.00	$G_{k,1}$	+	1.00	$Q_{k,6}$	
76 Kar.	1.00	$G_{k,1}$	+	1.00	$Q_{k,7}$	
77 Kar.	1.00	$G_{k,1}$	+	1.00	$Q_{k,8}$	
78 Kar.	1.00	$G_{k,1}$	+	1.00	$Q_{k,9}$	
79 Kar.	1.00	$G_{k,1}$	+	1.00	$Q_{k,10}$	
80 Kar.	1.00	$G_{k,1}$	+	1.00	$Q_{k,11}$	
81 Kar.	1.00	$G_{k,1}$	+	1.00	$Q_{k,12}$	
82 Kar.	1.00	$G_{k,1}$	+	1.00	$Q_{k,13}$	
83 Kar.	1.00	$G_{k,1}$	+	1.00	$Q_{k,14}$	
84 Kar.	1.00	$G_{k,1}$	+	1.00	$Q_{k,15}$	
85 Kar.	1.00	$G_{k,1}$	+	1.00	$Q_{k,16}$	
86 Kar.	1.00	$G_{k,1}$	+	1.00	$Q_{k,17}$	
87 Kar.	1.00	$G_{k,1}$	+	1.00	$Q_{k,18}$	
88 Kar.	1.00	$G_{k,1}$	+	1.00	$Q_{k,2}$	+ 1.00 $\Psi_0 Q_{k,18}$
89 Kar.	1.00	$G_{k,1}$	+	1.00	$Q_{k,3}$	+ 1.00 $\Psi_0 Q_{k,18}$
90 Kar.	1.00	$G_{k,1}$	+	1.00	$Q_{k,4}$	+ 1.00 $\Psi_0 Q_{k,18}$

91 Kar. 1.00 $G_{k,1}$ + 1.00 $Q_{k,5}$ + 1.00 Ψ_0 $Q_{k,18}$
 92 Kar. 1.00 $G_{k,1}$ + 1.00 $Q_{k,6}$ + 1.00 Ψ_0 $Q_{k,18}$
 93 Kar. 1.00 $G_{k,1}$ + 1.00 $Q_{k,7}$ + 1.00 Ψ_0 $Q_{k,18}$
 94 Kar. 1.00 $G_{k,1}$ + 1.00 $Q_{k,8}$ + 1.00 Ψ_0 $Q_{k,18}$
 Onderdeel....:

BELASTINGCOMBINATIES

BC Type					
95 Kar.	1.00	$G_{k,1}$	+	1.00	$Q_{k,9}$ + 1.00 Ψ_0 $Q_{k,18}$
96 Kar.	1.00	$G_{k,1}$	+	1.00	$Q_{k,10}$ + 1.00 Ψ_0 $Q_{k,18}$
97 Kar.	1.00	$G_{k,1}$	+	1.00	$Q_{k,11}$ + 1.00 Ψ_0 $Q_{k,18}$
98 Kar.	1.00	$G_{k,1}$	+	1.00	$Q_{k,12}$ + 1.00 Ψ_0 $Q_{k,18}$
99 Kar.	1.00	$G_{k,1}$	+	1.00	$Q_{k,13}$ + 1.00 Ψ_0 $Q_{k,18}$
100 Kar.	1.00	$G_{k,1}$	+	1.00	$Q_{k,14}$ + 1.00 Ψ_0 $Q_{k,18}$
101 Kar.	1.00	$G_{k,1}$	+	1.00	$Q_{k,15}$ + 1.00 Ψ_0 $Q_{k,18}$
102 Kar.	1.00	$G_{k,1}$	+	1.00	$Q_{k,16}$ + 1.00 Ψ_0 $Q_{k,18}$
103 Kar.	1.00	$G_{k,1}$	+	1.00	$Q_{k,17}$ + 1.00 Ψ_0 $Q_{k,18}$
104 Quas.	1.00	$G_{k,1}$			
105 Quas.	1.00	$G_{k,1}$	+	1.00	Ψ_2 $Q_{k,18}$
106 Freq.	1.00	$G_{k,1}$			
107 Freq.	1.00	$G_{k,1}$	+	1.00	Ψ_1 $Q_{k,2}$
108 Freq.	1.00	$G_{k,1}$	+	1.00	Ψ_1 $Q_{k,3}$
109 Freq.	1.00	$G_{k,1}$	+	1.00	Ψ_1 $Q_{k,4}$
110 Freq.	1.00	$G_{k,1}$	+	1.00	Ψ_1 $Q_{k,5}$
111 Freq.	1.00	$G_{k,1}$	+	1.00	Ψ_1 $Q_{k,6}$
112 Freq.	1.00	$G_{k,1}$	+	1.00	Ψ_1 $Q_{k,7}$
113 Freq.	1.00	$G_{k,1}$	+	1.00	Ψ_1 $Q_{k,8}$
114 Freq.	1.00	$G_{k,1}$	+	1.00	Ψ_1 $Q_{k,9}$
115 Freq.	1.00	$G_{k,1}$	+	1.00	Ψ_1 $Q_{k,10}$
116 Freq.	1.00	$G_{k,1}$	+	1.00	Ψ_1 $Q_{k,11}$
117 Freq.	1.00	$G_{k,1}$	+	1.00	Ψ_1 $Q_{k,12}$
118 Freq.	1.00	$G_{k,1}$	+	1.00	Ψ_1 $Q_{k,13}$
119 Freq.	1.00	$G_{k,1}$	+	1.00	Ψ_1 $Q_{k,14}$
120 Freq.	1.00	$G_{k,1}$	+	1.00	Ψ_1 $Q_{k,15}$
121 Freq.	1.00	$G_{k,1}$	+	1.00	Ψ_1 $Q_{k,16}$
122 Freq.	1.00	$G_{k,1}$	+	1.00	Ψ_1 $Q_{k,17}$
123 Freq.	1.00	$G_{k,1}$	+	1.00	Ψ_1 $Q_{k,18}$
124 Freq.	1.00	$G_{k,1}$	+	1.00	Ψ_1 $Q_{k,2}$ + 1.00 Ψ_2 $Q_{k,18}$
125 Freq.	1.00	$G_{k,1}$	+	1.00	Ψ_1 $Q_{k,3}$ + 1.00 Ψ_2 $Q_{k,18}$
126 Freq.	1.00	$G_{k,1}$	+	1.00	Ψ_1 $Q_{k,4}$ + 1.00 Ψ_2 $Q_{k,18}$
127 Freq.	1.00	$G_{k,1}$	+	1.00	Ψ_1 $Q_{k,5}$ + 1.00 Ψ_2 $Q_{k,18}$
128 Freq.	1.00	$G_{k,1}$	+	1.00	Ψ_1 $Q_{k,6}$ + 1.00 Ψ_2 $Q_{k,18}$
129 Freq.	1.00	$G_{k,1}$	+	1.00	Ψ_1 $Q_{k,7}$ + 1.00 Ψ_2 $Q_{k,18}$
130 Freq.	1.00	$G_{k,1}$	+	1.00	Ψ_1 $Q_{k,8}$ + 1.00 Ψ_2 $Q_{k,18}$
131 Freq.	1.00	$G_{k,1}$	+	1.00	Ψ_1 $Q_{k,9}$ + 1.00 Ψ_2 $Q_{k,18}$
132 Freq.	1.00	$G_{k,1}$	+	1.00	Ψ_1 $Q_{k,10}$ + 1.00 Ψ_2 $Q_{k,18}$
133 Freq.	1.00	$G_{k,1}$	+	1.00	Ψ_1 $Q_{k,11}$ + 1.00 Ψ_2 $Q_{k,18}$
134 Freq.	1.00	$G_{k,1}$	+	1.00	Ψ_1 $Q_{k,12}$ + 1.00 Ψ_2 $Q_{k,18}$
135 Freq.	1.00	$G_{k,1}$	+	1.00	Ψ_1 $Q_{k,13}$ + 1.00 Ψ_2 $Q_{k,18}$
136 Freq.	1.00	$G_{k,1}$	+	1.00	Ψ_1 $Q_{k,14}$ + 1.00 Ψ_2 $Q_{k,18}$
137 Freq.	1.00	$G_{k,1}$	+	1.00	Ψ_1 $Q_{k,15}$ + 1.00 Ψ_2 $Q_{k,18}$
138 Freq.	1.00	$G_{k,1}$	+	1.00	Ψ_1 $Q_{k,16}$ + 1.00 Ψ_2 $Q_{k,18}$
139 Freq.	1.00	$G_{k,1}$	+	1.00	Ψ_1 $Q_{k,17}$ + 1.00 Ψ_2 $Q_{k,18}$
140 Blij.	1.00	$G_{k,1}$			

GUNSTIGE WERKING PERMANENTE BELASTINGEN

BC Staven met gunstige werking

- 1 Geen
 - 2 Alle staven de factor:0.90
 - 3 Geen
 - 4 Geen
 - 5 Geen
 - 6 Geen
- Onderdeel....:

GUNSTIGE WERKING PERMANENTE BELASTINGEN

BC Staven met gunstige werking

- 7 Geen
- 8 Geen
- 9 Geen
- 10 Geen

- 11 Geen
- 12 Geen
- 13 Geen
- 14 Geen
- 15 Geen
- 16 Geen
- 17 Geen
- 18 Geen
- 19 Geen
- 20 Geen
- 21 Alle staven de factor:0.90
- 22 Alle staven de factor:0.90
- 23 Alle staven de factor:0.90
- 24 Alle staven de factor:0.90
- 25 Alle staven de factor:0.90
- 26 Alle staven de factor:0.90
- 27 Alle staven de factor:0.90
- 28 Alle staven de factor:0.90
- 29 Alle staven de factor:0.90
- 30 Alle staven de factor:0.90
- 31 Alle staven de factor:0.90
- 32 Alle staven de factor:0.90
- 33 Alle staven de factor:0.90
- 34 Alle staven de factor:0.90
- 35 Alle staven de factor:0.90
- 36 Alle staven de factor:0.90
- 37 Alle staven de factor:0.90
- 38 Alle staven de factor:0.90
- 39 Geen
- 40 Geen
- 41 Geen
- 42 Geen
- 43 Geen
- 44 Geen
- 45 Geen
- 46 Geen
- 47 Geen
- 48 Geen
- 49 Geen
- 50 Geen
- 51 Geen
- 52 Geen
- 53 Geen
- 54 Geen
- 55 Alle staven de factor:0.90
- 56 Alle staven de factor:0.90
- 57 Alle staven de factor:0.90
- 58 Alle staven de factor:0.90
- 59 Alle staven de factor:0.90
- 60 Alle staven de factor:0.90
- 61 Alle staven de factor:0.90
- 62 Alle staven de factor:0.90
- 63 Alle staven de factor:0.90
- 64 Alle staven de factor:0.90
- 65 Alle staven de factor:0.90
- 66 Alle staven de factor:0.90
- 67 Alle staven de factor:0.90
- 68 Alle staven de factor:0.90
- 69 Alle staven de factor:0.90
- 70 Alle staven de factor:0.90

Onderdeel.....:

OMHULLENDE VAN DE FUNDAMENTELE COMBINATIES

MOMENTEN

Fundamentele combinatie

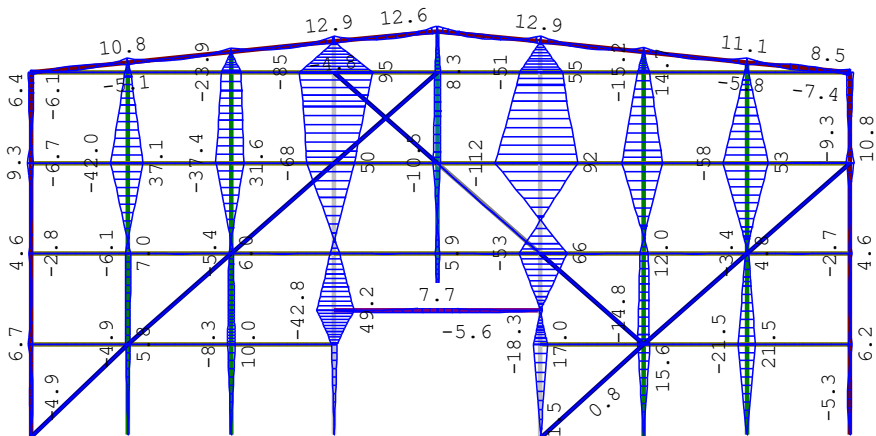

DWARSKRACHTEN

Fundamentele combinatie

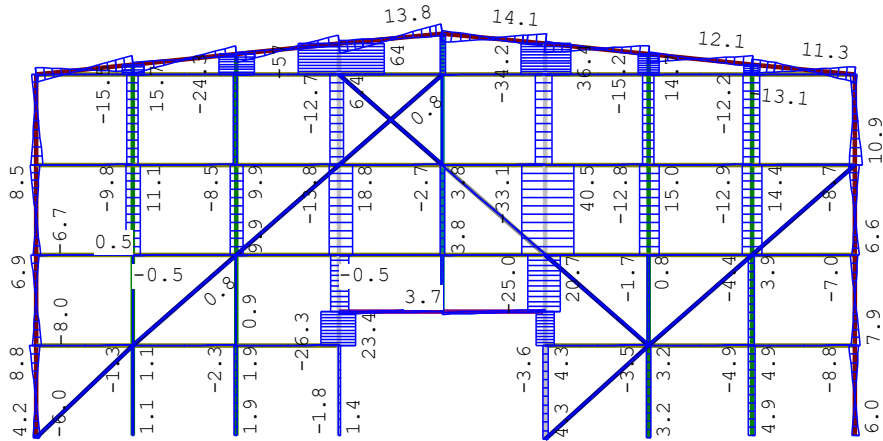

Onderdeel.....:

NORMAALKRACHTEN

Fundamentele combinatie

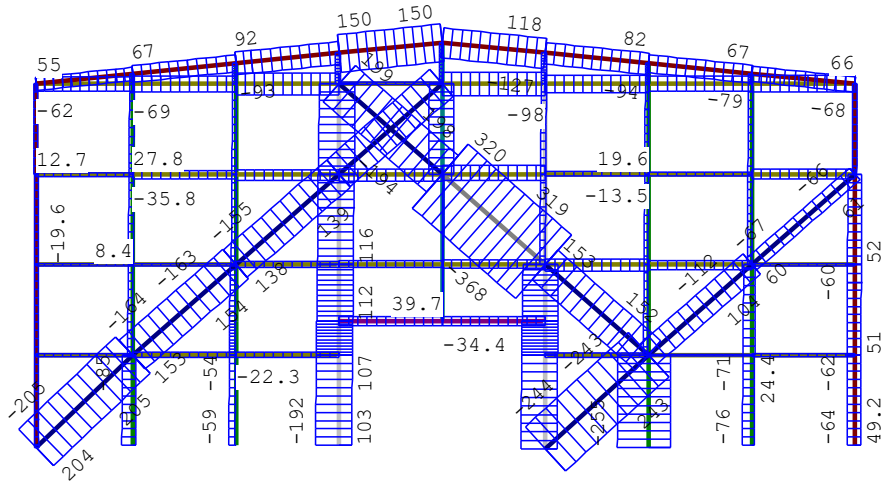

REACTIES

Fundamentele combinatie

Kn.	X-min	X-max	Z-min	Z-max	M-min	M-max
1	-153.69	151.68	-144.81	161.38		
3	-1.32	1.11	-21.15	90.14		
4	-2.28	1.89	7.98	58.61		
5	-1.82	1.44	-102.57	191.72		
7	-183.09	184.19	-14.85	120.56		
8	-3.47	3.20	-175.54	254.68		
9	-4.92	4.91	-20.81	76.15		
10	-3.86	5.98	-49.18	63.56		

OMHULLENDE VAN DE KARAKTERISTIEKE COMBINATIES

VERPLAATSINGEN

[mm]

Karakteristieke combinatie

28	5.000	Geschoord	5.000	0.0	Geschoord	5.000	0.0
29	4.375	Ongeschoord	4.380*	0.0	Geschoord	4.375	0.0
30	5.000	Geschoord	5.000	0.0	Geschoord	5.000	0.0
31	4.375	Ongeschoord	4.380*	0.0	Geschoord	4.375	0.0

Onderdeel.....:

KNIKSTABILITEIT

Staafl	l _{sys} [m]	Classif. y sterke as	l _{knik,y} [m]	Extra aanp. y [kN]	Classif. z zwakke as	l _{knik,z} [m]	Extra aanp. z [kN]
32	5.000	Ongeschoord	5.000*	0.0	Geschoord	5.000	0.0
33	4.375	Ongeschoord	4.380*	0.0	Geschoord	4.375	0.0
34	4.700	Geschoord	4.700	0.0	Geschoord	4.700	0.0
35	4.375	Ongeschoord	4.380*	0.0	Geschoord	4.375	0.0
36	5.000	Geschoord	5.000	0.0	Geschoord	5.000	0.0
37-59	4.375	Ongeschoord	4.380*	0.0	Geschoord	4.375	0.0
38	5.000	Geschoord	5.000	0.0	Geschoord	5.000	0.0
39	2.750	Ongeschoord	2.750*	0.0	Geschoord	2.750	0.0
40	5.000	Geschoord	5.000	0.0	Geschoord	5.000	0.0
41	2.750	Ongeschoord	2.750*	0.0	Geschoord	2.750	0.0
42	5.000	Geschoord	5.000	0.0	Geschoord	5.000	0.0
43	2.750	Ongeschoord	2.750*	0.0	Geschoord	2.750	0.0
44	5.000	Geschoord	5.000	0.0	Geschoord	5.000	0.0
45	5.000	Geschoord	5.000	0.0	Geschoord	5.000	0.0
46	4.375	Ongeschoord	4.380*	0.0	Geschoord	4.375	0.0
47	5.000	Geschoord	5.000	0.0	Geschoord	5.000	0.0
48	4.375	Ongeschoord	4.380*	0.0	Geschoord	4.375	0.0
49	4.375	Ongeschoord	4.380*	0.0	Geschoord	4.375	0.0
50	4.700	Geschoord	4.700	0.0	Geschoord	4.700	0.0
51	4.375	Ongeschoord	4.380*	0.0	Geschoord	4.375	0.0
52	5.000	Geschoord	5.000	0.0	Geschoord	5.000	0.0
53	4.375	Ongeschoord	4.380*	0.0	Geschoord	4.375	0.0
54	4.493	Ongeschoord	4.490*	0.0	Geschoord	4.493	0.0
55	5.000	Geschoord	5.000	0.0	Geschoord	5.000	0.0
56	4.375	Ongeschoord	4.380*	0.0	Geschoord	4.375	0.0
57	5.000	Geschoord	5.000*	0.0	Geschoord	5.000	0.0
58	4.375	Ongeschoord	4.380*	0.0	Geschoord	4.375	0.0
60	5.000	Geschoord	10.050*	0.0	Ongeschoord	10.125	0.0
61	1.625	Ongeschoord	1.620*	0.0	Geschoord	1.625	0.0
62	5.000	Geschoord	5.000	0.0	Geschoord	5.000	0.0
63	4.375	Ongeschoord	4.380*	0.0	Geschoord	4.375	0.0
64	4.724	Ongeschoord	4.720*	0.0	Geschoord	4.724	0.0
65	5.025	Ongeschoord	5.020*	0.0	Geschoord	5.025	0.0
66	4.375	Ongeschoord	4.380*	0.0	Geschoord	4.375	0.0
67	4.700	Geschoord	4.700	0.0	Geschoord	4.700	0.0
68	4.375	Ongeschoord	4.380*	0.0	Geschoord	4.375	0.0
69	5.000	Geschoord	10.050*	0.0	Ongeschoord	10.125	0.0
70	1.492	Ongeschoord	1.490*	0.0	Geschoord	1.492	0.0
71	5.026	Ongeschoord	5.030*	0.0	Geschoord	5.026	0.0
72	1.500	Ongeschoord	1.500*	0.0	Geschoord	1.500	0.0
73	5.025	Ongeschoord	5.020*	0.0	Geschoord	5.025	0.0
74	1.000	Ongeschoord	1.000*	0.0	Geschoord	1.000	0.0
75	5.025	Ongeschoord	5.020*	0.0	Geschoord	5.025	0.0
76	0.500	Ongeschoord	0.500*	0.0	Geschoord	0.500	0.0
77	5.025	Geschoord	5.025	0.0	Geschoord	5.025	0.0
78	0.985	Ongeschoord	0.980*	0.0	Geschoord	0.985	0.0
79	5.026	Ongeschoord	5.030*	0.0	Geschoord	5.026	0.0
80	0.477	Ongeschoord	0.480*	0.0	Geschoord	0.477	0.0
81	5.026	Ongeschoord	5.030*	0.0	Geschoord	5.026	0.0
82	1.625	Ongeschoord	1.620*	0.0	Geschoord	1.625	0.0
83	5.000	Geschoord	5.000	0.0	Geschoord	5.000	0.0
84	4.550	Ongeschoord	4.550*	0.0	Geschoord	4.550	0.0
85	4.375	Ongeschoord	4.380*	0.0	Geschoord	4.375	0.0
86	6.644	Geschoord	6.644	0.0	Geschoord	6.644	0.0

Onderdeel.....:

KNIKSTABILITEIT

Staafl	l _{sys} [m]	Classif. y sterke as	l _{knik,y} [m]	Extra aanp. y [kN]	Classif. z zwakke as	l _{knik,z} [m]	Extra aanp. z [kN]
87	6.644	Geschoord	6.644	0.0	Geschoord	6.644	0.0
88	6.644	Geschoord	6.644	0.0	Geschoord	6.644	0.0
89	6.502	Geschoord	6.502	0.0	Geschoord	6.502	0.0
90	6.644	Geschoord	6.644	0.0	Geschoord	6.644	0.0
91	6.644	Geschoord	6.644	0.0	Geschoord	6.644	0.0
92	6.644	Ongeschoord	6.640*	0.0	Geschoord	6.644	0.0
93	6.760	Geschoord	6.760	0.0	Geschoord	6.760	0.0
94	6.644	Geschoord	6.644	0.0	Geschoord	6.644	0.0

95 6.644 Geschoord 6.644 0.0 Geschoord 6.644 0.0
 * Door gebruiker gedefinieerde kniklengte

KIPSTABILITEIT

Staafl	Plts. aangr.		l gaffel [m]	Kipsteunafstanden [m]
1	1.0*h	boven:	4.49	4.493
		onder:		4.493
2	1.0*h	boven:	2.00	2.000
		onder:		2.000
3	1.0*h	boven:	4.70	4.700
		onder:		4.700
4	1.0*h	boven:	4.38	4.375
		onder:		4.375
5	1.0*h	boven:	5.00	5.000
		onder:		5.000
6	1.0*h	boven:	4.38	4.375
		onder:		4.375
7	1.0*h	boven:	5.00	5.000
		onder:		5.000
8	1.0*h	boven:	4.38	4.375
		onder:		4.375
9	1.0*h	boven:	5.00	5.000
		onder:		5.000
10	1.0*h	boven:	4.38	4.375
		onder:		4.375
11	1.0*h	boven:	5.00	5.000
		onder:		5.000
12	1.0*h	boven:	4.38	4.375
		onder:		4.375
13	1.0*h	boven:	5.00	5.000
		onder:		5.000
14	1.0*h	boven:	4.38	4.375
		onder:		4.375
15	1.0*h	boven:	5.00	5.000
		onder:		5.000
16	1.0*h	boven:	4.38	4.375
		onder:		4.375
17	1.0*h	boven:	5.00	5.000
		onder:		5.000
18	1.0*h	boven:	4.38	4.375
		onder:		4.375
19	1.0*h	boven:	4.38	4.375
		onder:		4.375
20	1.0*h	boven:	5.00	5.000
		onder:		5.000
21	1.0*h	boven:	4.38	4.375
		onder:		4.375
22	1.0*h	boven:	5.00	5.000
		onder:		5.000
23	1.0*h	boven:	4.38	4.375
		onder:		4.375

Onderdeel....:

KIPSTABILITEIT

Staafl	Plts. aangr.		l gaffel [m]	Kipsteunafstanden [m]
24	1.0*h	boven:	5.00	5.000
		onder:		5.000
25	1.0*h	boven:	4.38	4.375
		onder:		4.375
26	1.0*h	boven:	5.00	5.000
		onder:		5.000
27	1.0*h	boven:	4.38	4.375
		onder:		4.375
28	1.0*h	boven:	5.00	5.000
		onder:		5.000
29	1.0*h	boven:	4.38	4.375
		onder:		4.375
30	1.0*h	boven:	5.00	5.000
		onder:		5.000
31	1.0*h	boven:	4.38	4.375
		onder:		4.375
32	1.0*h	boven:	5.00	5.000
		onder:		5.000
33	1.0*h	boven:	4.38	4.375
		onder:		4.375
34	1.0*h	boven:	4.70	4.700
		onder:		4.700
35	1.0*h	boven:	4.38	4.375
		onder:		4.375
36	1.0*h	boven:	5.00	5.000

37-59	1.0*h	onder:	5.000
		boven:	4.38 4.375
38	1.0*h	onder:	4.375
		boven:	5.00 5.000
39	1.0*h	onder:	5.000
		boven:	2.75 2.750
40	1.0*h	onder:	2.750
		boven:	5.00 5.000
		onder:	5.000
41	1.0*h	boven:	2.75 2.750
		onder:	2.750
42	1.0*h	boven:	5.00 5.000
		onder:	5.000
43	1.0*h	boven:	2.75 2.750
		onder:	2.750
44	1.0*h	boven:	5.00 5.000
		onder:	5.000
45	1.0*h	boven:	5.00 5.000
		onder:	5.000
46	1.0*h	boven:	4.38 4.375
		onder:	4.375
47	1.0*h	boven:	5.00 5.000
		onder:	5.000
48	1.0*h	boven:	4.38 4.375
		onder:	4.375
49	1.0*h	boven:	4.38 4.375
		onder:	4.375
50	1.0*h	boven:	4.70 4.700
		onder:	4.700
51	1.0*h	boven:	4.38 4.375
		onder:	4.375
52	1.0*h	boven:	5.00 5.000
		onder:	5.000

Onderdeel.....:

KIPSTABILITEIT

Staaft	Plts.		l gaffel	Kipsteunafstanden
aangr.			[m]	[m]
53	1.0*h	boven:	4.38	4.375
		onder:		4.375
54	1.0*h	boven:	4.49	4.493
		onder:		4.493
55	1.0*h	boven:	5.00	5.000
		onder:		5.000
56	1.0*h	boven:	4.38	4.375
		onder:		4.375
57	1.0*h	boven:	5.00	5.000
		onder:		5.000
58	1.0*h	boven:	4.38	4.375
		onder:		4.375
60	1.0*h	boven:	5.00	5.000
		onder:		5.000
61	1.0*h	boven:	1.62	1.625
		onder:		1.625
62	1.0*h	boven:	5.00	5.000
		onder:		5.000
63	1.0*h	boven:	4.38	4.375
		onder:		4.375
64	1.0*h	boven:	4.72	4.724
		onder:		4.724
65	1.0*h	boven:	5.02	5.025
		onder:		5.025
66	1.0*h	boven:	4.38	4.375
		onder:		4.375
67	1.0*h	boven:	4.70	4.700
		onder:		4.700
68	1.0*h	boven:	4.38	4.375
		onder:		4.375
69	1.0*h	boven:	5.00	5.000
		onder:		5.000
70	1.0*h	boven:	1.49	1.492
		onder:		1.492
71	1.0*h	boven:	5.03	5.026
		onder:		5.026
72	1.0*h	boven:	1.50	1.500
		onder:		1.500
73	1.0*h	boven:	5.02	5.025
		onder:		5.025
74	1.0*h	boven:	1.00	1.000
		onder:		1.000
75	1.0*h	boven:	5.02	5.025
		onder:		5.025

76	1.0*h	boven:	0.50	0.500
		onder:		0.500
77	1.0*h	boven:	5.02	5.025
		onder:		5.025
78	1.0*h	boven:	0.98	0.985
		onder:		0.985
79	1.0*h	boven:	5.03	5.026
		onder:		5.026
80	1.0*h	boven:	0.48	0.477
		onder:		0.477
81	1.0*h	boven:	5.03	5.026
		onder:		5.026
82	1.0*h	boven:	1.62	1.625
		onder:		1.625

Onderdeel....:

KIPSTABILITEIT

Staafl	Plts. aangr.		1 gaffel [m]	Kipsteunafstanden [m]
83	1.0*h	boven:	5.00	5.000
		onder:		5.000
84	1.0*h	boven:	4.55	4.550
		onder:		4.550
85	1.0*h	boven:	4.38	4.375
		onder:		4.375
86	1.0*h	boven:	6.64	6.644
		onder:		6.644
87	1.0*h	boven:	6.64	6.644
		onder:		6.644
88	1.0*h	boven:	6.64	6.644
		onder:		6.644
89	1.0*h	boven:	6.50	6.502
		onder:		6.502
90	1.0*h	boven:	6.64	6.644
		onder:		6.644
91	1.0*h	boven:	6.64	6.644
		onder:		6.644
92	1.0*h	boven:	6.64	6.644
		onder:		6.644
93	1.0*h	boven:	6.76	6.760
		onder:		6.760
94	1.0*h	boven:	6.64	6.644
		onder:		6.644
95	1.0*h	boven:	6.64	6.644
		onder:		6.644

TOETSING SPANNINGEN

Staafl nr.	P/M	BC	Sit	Kl	Plaats	Norm	Artikel	Formule	Hoogste toetsing U.C. [N/mm ²]	Opm.
1	1	43	1	1	Staafl	EN3-1-1	6.3.3	(6.62)	0.146	34
2	6	51	1	1	Staafl	EN3-1-1	6.3.3	(6.62)	0.053	19
3	3	43	1	2	Staafl	EN3-1-1	6.3.1.1	(6.46z)	0.327	77
4	2	43	1	1	Staafl	EN3-1-1	6.3.3	(6.62)	0.070	25
5	3	39	1	2	Staafl	EN3-1-1	6.3.1.1	(6.46z)	0.399	94
6	2	43	1	1	Staafl	EN3-1-1	6.3.3	(6.62)	0.064	23
7	3	39	1	2	Staafl	EN3-1-1	6.3.1.1	(6.46z)	0.518	122
8	7	51	1	1	Staafl	EN3-1-1	6.3.3	(6.62)	0.191	45
9	3	6	1	1	Staafl	EN3-1-1	6.3.3	(6.61)	0.046	11
10	6	43	1	4	Staafl	EN3-1-1	6.3.3	(6.62)	0.261	88
11	3	47	1	2	Staafl	EN3-1-1	6.3.1.1	(6.46z)	0.566	133
12	7	43	1	1	Staafl	EN3-1-1	6.3.3	(6.62)	0.152	36
13	3	29	1	2	Staafl	EN3-1-1	6.3.1.1	(6.46z)	0.402	94
14	2	43	1	1	Staafl	EN3-1-1	6.3.3	(6.62)	0.087	31
15	3	29	1	2	Staafl	EN3-1-1	6.3.1.1	(6.46z)	0.359	84
16	2	43	1	1	Staafl	EN3-1-1	6.3.3	(6.62)	0.093	33
17	3	29	1	2	Staafl	EN3-1-1	6.3.1.1	(6.46z)	0.368	87
18	1	31	1	1	Staafl	EN3-1-1	6.3.2	(6.54)	0.207	49
19	2	43	1	1	Staafl	EN3-1-1	6.3.3	(6.62)	0.073	26
20	3	45	1	2	Staafl	EN3-1-1	6.3.1.1	(6.46z)	0.206	49
21	2	43	1	1	Staafl	EN3-1-1	6.3.3	(6.62)	0.067	24
22	3	43	1	2	Staafl	EN3-1-1	6.3.1.1	(6.46z)	0.278	65
23	7	51	1	1	Staafl	EN3-1-1	6.3.3	(6.62)	0.128	30
24	3	43	1	2	Staafl	EN3-1-1	6.3.1.1	(6.46z)	0.337	79
25	6	43	1	1	Begin	EN3-1-1	6.2.10	(6.45+6.31y)	0.052	18
26	3	31	1	2	Staafl	EN3-1-1	6.3.1.1	(6.46z)	0.311	73
27	7	43	1	1	Staafl	EN3-1-1	6.3.3	(6.62)	0.154	36
28	3	31	1	2	Staafl	EN3-1-1	6.3.1.1	(6.46z)	0.078	18

Onderdeel....:

TOETSING SPANNINGEN

Staaflnr.	P/M	BC	Sit	Kl	Plaats	Norm	Artikel	Formule	Hoogste toetsing U.C. [N/mm ²]	Opm.	
29	2	43	1	1	Staafl	EN3-1-1	6.3.3	(6.62)	0.090	32	47
30	3	23	1	2	Staafl	EN3-1-1	6.3.1.1	(6.46z)	0.068	16	
31	2	43	1	1	Staafl	EN3-1-1	6.3.3	(6.62)	0.096	34	47
32	3	39	1	1	Staafl	EN3-1-1	6.3.3	(6.61)	0.216	51	
33	1	43	1	1	Staafl	EN3-1-1	6.3.3	(6.62)	0.226	53	47
34	3	43	1	2	Staafl	EN3-1-1	6.3.3	(6.61)	0.072	17	
35	2	39	1	4	Staafl	EN3-1-1	6.3.3	(6.62)	0.043	10	47,129
36	3	12	1	1	Staafl	EN3-1-1	6.3.3	(6.61)	0.055	13	
37-59	2	43	1	4	Staafl	EN3-1-1	6.3.3	(6.62)	0.057	14	47,129
38	3	31	1	2	Staafl	EN3-1-1	6.3.1.1	(6.46z)	0.140	33	
39	7	51	1	4	Staafl	EN3-1-1	6.3.1.1	T(6.46)	0.148	33	47,129,8,4
40	3	31	1	2	Staafl	EN3-1-1	6.3.1.1	(6.46z)	0.145	34	
41	6	43	1	1	Begin	EN3-1-1	6.2.10	(6.45+6.31y)	0.029	10	
42	3	31	1	2	Staafl	EN3-1-1	6.3.1.1	(6.46z)	0.168	40	
43	7	43	1	1	Staafl	EN3-1-1	6.3.1.1	T(6.46)	0.196	46	47,8,4
44	3	39	1	2	Staafl	EN3-1-1	6.3.1.1	(6.46z)	0.315	74	
45	3	39	1	2	Staafl	EN3-1-1	6.3.1.1	(6.46z)	0.231	54	
46	2	43	1	1	Staafl	EN3-1-1	6.3.3	(6.62)	0.067	24	47
47	3	51	1	2	Staafl	EN3-1-1	6.3.1.1	(6.46z)	0.079	18	
48	1	43	1	1	Staafl	EN3-1-1	6.3.3	(6.62)	0.169	40	47
49	1	43	1	1	Staafl	EN3-1-1	6.3.3	(6.62)	0.138	33	47
50	3	6	1	2	Staafl	EN3-1-1	6.3.1.1	(6.46z)	0.089	21	
51	2	43	1	4	Staafl	EN3-1-1	6.3.3	(6.62)	0.073	17	47,129
52	3	29	1	2	Staafl	EN3-1-1	6.3.1.1	(6.46z)	0.115	27	
53	2	43	1	4	Staafl	EN3-1-1	6.3.3	(6.62)	0.061	14	47,129
54	2	43	1	4	Staafl	EN3-1-1	6.3.3	(6.62)	0.209	50	47,129
55	3	53	1	1	Staafl	EN3-1-1	6.3.3	(6.61)	0.054	13	
56	2	43	1	1	Staafl	EN3-1-1	6.3.3	(6.62)	0.070	25	47
57	3	35	1	2	Staafl	EN3-1-1	6.3.1.1	(6.46z)	0.096	23	
58	1	44	1	1	Staafl	EN3-1-1	6.3.3	(6.62)	0.213	50	47
60	5	12	1	1	Staafl	EN3-1-1	6.3.3	(6.62)	0.084	20	
61	7	51	1	4	Staafl	EN3-1-1	6.3.1.1	T(6.46)	0.131	29	47,129,8,4
62	3	29	1	2	Staafl	EN3-1-1	6.3.1.1	(6.46z)	0.129	30	
63	7	51	1	4	Staafl	EN3-1-1	6.3.3	(6.62)	0.096	22	47,129
64	1	51	1	1	Staafl	EN3-1-1	6.3.3	(6.62)	0.301	71	47
65	1	45	1	1	Staafl	EN3-1-1	6.3.3	(6.62)	0.564	133	46,47
66	1	27	1	1	Staafl	EN3-1-1	6.3.2	(6.54)	0.177	42	
67	3	23	1	2	Staafl	EN3-1-1	6.3.1.1	(6.46z)	0.100	23	
68	1	27	1	1	Begin	EN3-1-1	6.2.10	(6.45+6.31y)	0.177	42	
69	5	12	1	1	Staafl	EN3-1-1	6.3.3	(6.62)	0.085	20	
70	7	51	1	1	Staafl	EN3-1-1	6.3.1.1	T(6.46)	0.150	35	47,8,4
71	1	51	1	1	Staafl	EN3-1-1	6.3.3	(6.62)	0.636	149	46,47
72	7	47	1	1	Staafl	EN3-1-1	6.3.1.1	T(6.46)	0.087	21	47,8,4
73	1	45	1	1	Staafl	EN3-1-1	6.3.3	(6.62)	0.455	107	47
74	2	43	1	1	Staafl	EN3-1-1	6.3.1.1	T(6.46)	0.031	11	47,8,4
75	1	43	1	1	Staafl	EN3-1-1	6.3.3	(6.62)	0.399	94	47
76	2	45	1	4	Staafl	EN3-1-1	6.3.3	(6.61)	0.019	5	47,129,8,4
77	1	43	1	1	Staafl	EN3-1-1	6.3.3	(6.62)	0.370	87	47
78	2	51	1	1	Staafl	EN3-1-1	6.3.1.1	T(6.46)	0.046	16	47,8,4
79	1	51	1	1	Staafl	EN3-1-1	6.3.3	(6.62)	0.434	102	47
80	2	51	1	1	Staafl	EN3-1-1	6.3.1.1	T(6.46)	0.019	7	47,8,4
81	1	51	1	1	Staafl	EN3-1-1	6.3.3	(6.62)	0.361	85	47
82	7	43	1	4	Staafl	EN3-1-1	6.3.1.1	T(6.46)	0.100	22	47,129,8,4
83	3	29	1	2	Staafl	EN3-1-1	6.3.1.1	(6.46z)	0.104	24	

Onderdeel.....:

TOETSING SPANNINGEN

Staaflnr.	P/M	BC	Sit	Kl	Plaats	Norm	Artikel	Formule	Hoogste toetsing U.C. [N/mm ²]	Opm.	
84	7	43	1	4	Staafl	EN3-1-1	6.3.3	(6.62)	0.118	27	47,129
85	2	47	1	1	Staafl	EN3-1-1	6.3.3	(6.62)	0.043	15	47
86	4	51	1	1	Staafl	EN3-1-1	6.3.3	(6.61)	0.579	136	47
87	4	51	1	1	Staafl	EN3-1-1	6.3.3	(6.61)	0.579	136	47
88	4	47	1	1	Staafl	EN3-1-1	6.3.3	(6.61)	0.612	144	47
89	4	48	1	1	Staafl	EN3-1-1	6.3.3	(6.61)	0.725	170	47
90	4	4	1	1	Staafl	EN3-1-1	6.3.3	(6.61)	0.715	168	47
91	8	43	1	1	Staafl	EN3-1-1	6.3.3	(6.61)	0.922	217	47
92	4	39	1	1	Staafl	EN3-1-1	6.3.3	(6.61)	0.631	148	47
93	4	12	1	1	Staafl	EN3-1-1	6.3.3	(6.61)	0.893	210	47
94	4	47	1	1	Staafl	EN3-1-1	6.3.3	(6.61)	0.430	101	47
95	4	47	1	1	Staafl	EN3-1-1	6.3.3	(6.61)	0.267	63	47

Opmerkingen:

[4] Controle van de gedrukte T-rand houdt geen rekening met 2e-orde-wringing.

[8] Controle van de gedrukte rand is toegepast (zonder buiging!).

- [46] T.b.v. kip is een equivalente Q-last berekend.
- [47] Bij verlopende normaalkracht wordt de grootste drukkracht genomen.
- [129] Bij berekening van klasse 4 profielen is gebruik gemaakt van de spanningsreductiemethode.

TOETSING DOORBUIGING

Staaft	Soort	Mtg	Lengte [m]	Overst I J	Zeeg [mm]	u _{tot} [mm]	BC	Sit	u [mm]	Toelaatbaar [mm]	*1
3	Vloer	db	4.70	N N	0.0	-0.8	71	1 Eind	-0.8	±18.8	0.004
	ss	74						1 Bijk	0.2	±28.2	2*0.003
5	Vloer	db	5.00	N N	0.0	-1.1	71	1 Eind	-1.1	±20.0	0.004
	ss	79						1 Bijk	-0.0	±30.0	2*0.003
7	Vloer	db	5.00	N N	0.0	-1.1	84	1 Eind	-1.1	±20.0	0.004
	ss	88						1 Bijk	0.5	±30.0	2*0.003
9	Vloer	ss	5.00	N N	0.0	-4.4	92	1 Eind	-4.4	±40.0	2*0.004
	ss	92						1 Bijk	-3.8	±30.0	2*0.003
11	Vloer	ss	5.00	N N	0.0	-3.6	92	1 Eind	-3.6	±40.0	2*0.004
	ss	92						1 Bijk	-3.0	±30.0	2*0.003
13	Vloer	db	5.00	N N	0.0	-1.1	71	1 Eind	-1.1	±20.0	0.004
	ss	90						1 Bijk	-0.0	±30.0	2*0.003
15	Vloer	db	5.00	N N	0.0	-1.1	73	1 Eind	-1.1	±20.0	0.004
	ss	71						1 Bijk	-0.2	±30.0	2*0.003
17	Vloer	db	5.00	N N	0.0	-1.1	76	1 Eind	-1.1	±20.0	0.004
	ss	82						1 Bijk	0.6	±30.0	2*0.003
20	Vloer	db	5.00	N N	0.0	-1.1	73	1 Eind	-1.1	±20.0	0.004
	ss	80						1 Bijk	-0.0	±30.0	2*0.003
22	Vloer	db	5.00	N N	0.0	-1.1	71	1 Eind	-1.1	±20.0	0.004
	ss	88						1 Bijk	-0.4	±30.0	2*0.003
24	Vloer	ss	5.00	N N	0.0	-4.0	92	1 Eind	-4.0	±40.0	2*0.004
	ss	92						1 Bijk	-3.4	±30.0	2*0.003
26	Vloer	ss	5.00	N N	0.0	-3.3	92	1 Eind	-3.3	±40.0	2*0.004
	ss	92						1 Bijk	-2.7	±30.0	2*0.003
28	Vloer	db	5.00	N N	0.0	-1.1	74	1 Eind	-1.1	±20.0	0.004
	ss	90						1 Bijk	-0.0	±30.0	2*0.003
30	Vloer	db	5.00	N N	0.0	-1.1	78	1 Eind	-1.1	±20.0	0.004
	ss	88						1 Bijk	-0.2	±30.0	2*0.003
32	Vloer	db	5.00	N N	0.0	-1.7	82	1 Eind	-1.7	±20.0	0.004
	db	82						1 Bijk	-1.3	±15.0	0.003
34	Vloer	db	4.70	N N	0.0	-0.8	72	1 Eind	-0.8	±18.8	0.004
	ss	74						1 Bijk	-0.1	±28.2	2*0.003
36	Vloer	db	5.00	N N	0.0	-1.1	72	1 Eind	-1.1	±20.0	0.004
	ss	88						1 Bijk	-0.0	±30.0	2*0.003
38	Vloer	db	5.00	N N	0.0	-1.1	81	1 Eind	-1.1	±20.0	0.004
	ss	88						1 Bijk	-0.3	±30.0	2*0.003
40	Vloer	ss	5.00	N N	0.0	-3.9	92	1 Eind	-3.9	±40.0	2*0.004
	ss	92						1 Bijk	-3.3	±30.0	2*0.003

Onderdeel....:

TOETSING DOORBUIGING

Staaft	Soort	Mtg	Lengte [m]	Overst I J	Zeeg [mm]	u _{tot} [mm]	BC	Sit	u [mm]	Toelaatbaar [mm]	*1
42	Vloer	ss	5.00	N N	0.0	-3.4	92	1 Eind	-3.4	±40.0	2*0.004
	ss	92						1 Bijk	-2.8	±30.0	2*0.003
44	Vloer	db	5.00	N N	0.0	-1.1	77	1 Eind	-1.1	±20.0	0.004
	ss	73						1 Bijk	-0.0	±30.0	2*0.003
45	Vloer	db	5.00	N N	0.0	-1.1	76	1 Eind	-1.1	±20.0	0.004
	ss	88						1 Bijk	-0.2	±30.0	2*0.003
47	Vloer	db	5.00	N N	0.0	-1.1	82	1 Eind	-1.1	±20.0	0.004
	ss	82						1 Bijk	0.3	±30.0	2*0.003
50	Vloer	db	4.70	N N	0.0	-0.8	71	1 Eind	-0.8	±18.8	0.004
	ss	77						1 Bijk	-0.1	±28.2	2*0.003
52	Vloer	db	5.00	N N	0.0	-1.1	79	1 Eind	-1.1	±20.0	0.004
	ss	88						1 Bijk	-0.0	±30.0	2*0.003
55	Vloer	db	5.00	N N	0.0	-1.1	77	1 Eind	-1.1	±20.0	0.004
	ss	88						1 Bijk	-0.2	±30.0	2*0.003
57	Vloer	db	5.00	N N	0.0	-1.1	72	1 Eind	-1.1	±20.0	0.004
	ss	82						1 Bijk	0.2	±30.0	2*0.003
60	Vloer	ss	5.00	N N	0.0	-3.5	92	1 Eind	-3.5	±40.0	2*0.004
	ss	92						1 Bijk	-2.8	±30.0	2*0.003
62	Vloer	db	5.00	N N	0.0	-1.1	81	1 Eind	-1.1	±20.0	0.004
	ss	88						1 Bijk	-0.1	±30.0	2*0.003
64	Dak	db	4.72	N N	0.0	-2.3	92	1 Eind	-2.3	-18.9	0.004
	db	92						1 Bijk	-1.3	-18.9	0.004
65	Dak	ss	5.02	N N	0.0	-3.5	88	1 Eind	-3.5	-40.2	2*0.004
	db	94						1 Bijk	-2.2	-20.1	0.004
67	Vloer	db	4.70	N N	0.0	-0.8	71	1 Eind	-0.8	±18.8	0.004
	ss	74						1 Bijk	-0.2	±28.2	2*0.003
69	Vloer	ss	5.00	N N	0.0	-3.9	92	1 Eind	-3.9	±40.0	2*0.004
	ss	92						1 Bijk	-3.2	±30.0	2*0.003
71	Dak	ss	5.03	N N	0.0	-4.5	92	1 Eind	-4.5	-40.2	2*0.004
	ss	92						1 Bijk	-3.9	-40.2	2*0.004
73	Dak	db	5.02	N N	0.0	-2.2	100	1 Eind	-2.2	-20.1	0.004
	db	100						1 Bijk	-1.4	-20.1	0.004

75	Dak	db	5.02	N	N	0.0	-1.8	94	1	Eind	-1.8	-20.1	0.004
		db						94	1	Bijk	-1.2	-20.1	0.004
77	Dak	db	5.02	N	N	0.0	-3.3	96	1	Eind	-3.3	-20.1	0.004
		db						96	1	Bijk	-2.0	-20.1	0.004
79	Dak	db	5.03	N	N	0.0	-2.0	100	1	Eind	-2.0	-20.1	0.004
		db						100	1	Bijk	-1.2	-20.1	0.004
81	Dak	db	5.03	N	N	0.0	-2.1	90	1	Eind	-2.1	-20.1	0.004
		db						90	1	Bijk	-1.3	-20.1	0.004
83	Vloer	db	5.00	N	N	0.0	-1.1	72	1	Eind	-1.1	±20.0	0.004
		ss						88	1	Bijk	-0.1	±30.0	2*0.003

TOETSING HORIZONTALE VERPLAATSING

Staaaf	BC	Sit	Lengte [m]	u_{eind} [mm]	Toelaatbaar [mm]	Maatgevend [h/]
1	88	1	4.493	-2.5	15.0	300 scheefstand
2	88	1	2.000	-4.0	6.7	300 scheefstand
4	93	1	4.375	-5.8	14.6	300 scheefstand
6	93	1	4.375	-5.4	14.6	300 scheefstand
8	92	1	4.375	-5.0	14.6	300 scheefstand
10	92	1	4.375	-5.6	14.6	300 scheefstand
12	88	1	4.375	-5.7	14.6	300 scheefstand
14	88	1	4.375	-6.2	14.6	300 scheefstand
16	88	1	4.375	-6.8	14.6	300 scheefstand
18	88	1	4.375	-7.8	14.6	300 scheefstand
19	97	1	4.375	1.9	14.6	300 scheefstand
21	97	1	4.375	1.6	14.6	300 scheefstand
23	101	1	4.375	1.1	14.6	300 scheefstand

Onderdeel....:

TOETSING HORIZONTALE VERPLAATSING

Staaaf	BC	Sit	Lengte [m]	u_{eind} [mm]	Toelaatbaar [mm]	Maatgevend [h/]
25	100	1	4.375	0.7	14.6	300 scheefstand
27	100	1	4.375	0.9	14.6	300 scheefstand
29	101	1	4.375	1.3	14.6	300 scheefstand
31	99	1	4.375	1.4	14.6	300 scheefstand
33	82	1	4.375	1.1	14.6	300 scheefstand
35	97	1	4.375	1.7	14.6	300 scheefstand
37-59	97	1	4.375	1.6	14.6	300 scheefstand
39	101	1	2.750	0.8	9.2	300 scheefstand
41	97	1	2.750	0.9	9.2	300 scheefstand
43	89	1	2.750	-1.1	9.2	300 scheefstand
46	80	1	4.375	1.0	14.6	300 scheefstand
48	97	1	4.375	0.9	14.6	300 scheefstand
49	97	1	4.375	1.7	14.6	300 scheefstand
51	88	1	4.375	-2.4	14.6	300 scheefstand
53	88	1	4.375	-2.5	14.6	300 scheefstand
54	89	1	4.493	-3.0	15.0	300 scheefstand
56	89	1	4.375	-3.1	14.6	300 scheefstand
58	89	1	4.375	-3.2	14.6	300 scheefstand
61	89	1	1.625	-0.8	5.4	300 scheefstand
63	88	1	4.375	-2.7	14.6	300 scheefstand
66	97	1	4.375	1.9	14.6	300 scheefstand
68	93	1	4.375	-6.2	14.6	300 scheefstand
70	88	1	1.492	-2.9	5.0	300 scheefstand
72	88	1	1.500	-3.0	5.0	300 scheefstand
74	88	1	1.000	-1.9	3.3	300 scheefstand
76	88	1	0.500	-1.0	1.7	300 scheefstand
78	88	1	0.985	-1.7	3.3	300 scheefstand
80	93	1	0.477	-0.8	1.6	300 scheefstand
82	88	1	1.625	-0.8	5.4	300 scheefstand
84	89	1	4.550	-2.9	15.2	300 scheefstand
85	79	1	4.375	1.3	14.6	300 scheefstand

TOETSING HOR. VERPLAATSING GLOBAAL

Er is een maximale horizontale verplaatsing van 0.0141 [m] gevonden bij knoop 6 en combinatie 88; belastingsituatie 1 (combinatietype 2). Bij een hoogte van 19.675 [m] levert dit h /1400 (toel.: h / 300).

A - 4 Facade 1

Technosoft Raamwerken release 6.79a

17 jan 2024

Project.....: MM20152 - as 1
 Dimensies....: kN;m;rad (tenzij anders aangegeven)
 Bestand.....: K:\Projecten\MM20152\10 Constructeur\03 DO - Definitief
 Ontwerp\reacties\facade1.rww

Belastingbreedte.: 2.400
 Rekenmodel.....: 1e-orde-elastisch.
 Theorie voor de bepaling van de krachtsverdeling:
 Geometrisch lineair.
 Fysisch lineair.

Gunstige werking van de permanente belasting wordt automatisch verwerkt.

Toegepaste normen volgens Eurocode met Nederlandse NB

Belastingen	NEN-EN 1990:2002	C2:2010,A1:2019	NB:2019(nl)
	NEN-EN 1991-1-1:2002	C1/C11:2019	NB:2019(nl)
Staal	NEN-EN 1993-1-1:2006	C2:2011,A1:2016	NB:2016(nl)

GOMETRIE

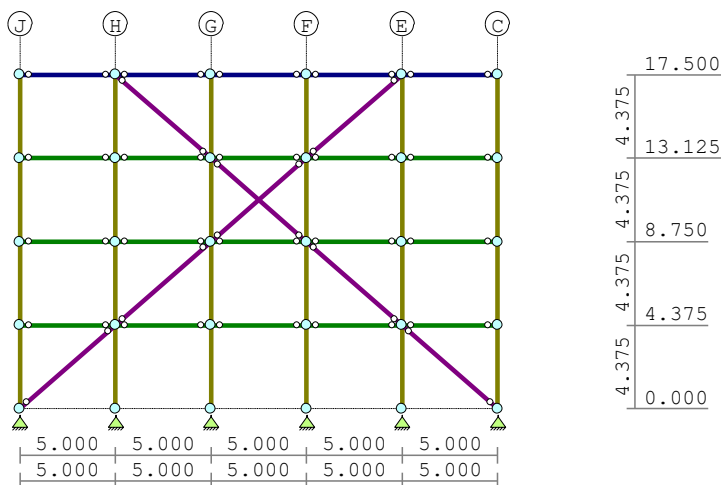

STRAMIENLIJNEN

Nr.	Naam	X	Z-min	Z-max
1	J	0.000	-0.153	17.500
2	H	5.000	-0.153	17.500
3	G	10.000	-0.153	17.500
4	F	15.000	-0.153	17.500
5	E	20.000	-0.153	17.500
6	C	25.000	-0.153	17.500

NIVEAUS

Nr.	Z	X-min	X-max
1	0.000	0.000	25.000
2	17.500	0.000	25.000
3	4.375	0.000	25.000
4	8.750	0.000	25.000
5	13.125	0.000	25.000

Onderdeel.....:

MATERIALEN

Mt	Kwaliteit	E-modulus[N/mm2]	S.G.	Pois.	Uitz. coëff
1	S235	210000	78.5	0.30	1.2000e-05

PROFIELEN [mm]

Prof.	Omschrijving	Materiaal	Oppervlak	Traagheid	Vormf.
1	HEA160	1:S235	3.8800e+03	1.6730e+07	0.00
2	K150/100/4CF	1:S235	1.8948e+03	5.9460e+06	0.00
3	IPE600	1:S235	1.5600e+04	9.2080e+08	0.00
4	K160/160/5CF	1:S235	3.0356e+03	1.2024e+07	0.00
5	K150/150/5CF	1:S235	2.8356e+03	9.8212e+06	0.00

PROFIELEN vervolg [mm]

Prof.	Staaftype	Breedte	Hoogte	e	Type	b1	h1	b2	h2
1	0:Normaal	160	152	76.0					
2	0:Normaal	100	150	75.0					
3	0:Normaal	220	600	300.0					
4	0:Normaal	160	160	80.0					

5 0:Normaal 150 150 75.0

PROFIELVORMEN [mm]

1 HEA160



2 K150/100/4CF



3 IPE600



4 K160/160/5CF



5 K150/150/5CF



KNOPEN

Knoop	X	Z	Knoop	X	Z
1	0.000	17.500	6	20.000	0.000
2	25.000	17.500	7	15.000	17.500
3	0.000	0.000	8	15.000	0.000
4	25.000	0.000	9	10.000	17.500
5	20.000	17.500	10	10.000	0.000
11	5.000	17.500	16	10.000	13.125
12	5.000	0.000	17	15.000	13.125
13	0.000	13.125	18	20.000	13.125
14	25.000	13.125	19	0.000	8.750
15	5.000	13.125	20	5.000	8.750
21	10.000	8.750	26	5.000	4.375
22	15.000	8.750	27	10.000	4.375
23	20.000	8.750	28	15.000	4.375
24	25.000	8.750	29	20.000	4.375
25	0.000	4.375	30	25.000	4.375

Onderdeel.....:

STAVEN

St.	ki	kj	Profiel	Aansl.i	Aansl.j	Lengte	Opm.
1	1	11	4:K160/160/5CF	ND-	ND-	5.000	
2	1	13	3:IPE600	NDM	NDM	4.375	
3	2	14	3:IPE600	NDM	NDM	4.375	
4	5	2	4:K160/160/5CF	ND-	ND-	5.000	
5	5	18	3:IPE600	NDM	NDM	4.375	
6	7	5	4:K160/160/5CF	ND-	ND-	5.000	
7	7	17	3:IPE600	NDM	NDM	4.375	
8	9	7	4:K160/160/5CF	ND-	ND-	5.000	
9	9	16	3:IPE600	NDM	NDM	4.375	
10	11	9	4:K160/160/5CF	ND-	ND-	5.000	
11	11	15	3:IPE600	NDM	NDM	4.375	
12	13	19	3:IPE600	NDM	NDM	4.375	
13	14	24	3:IPE600	NDM	NDM	4.375	
14	13	15	2:K150/100/4CF	ND-	ND-	5.000	
15	15	20	3:IPE600	NDM	NDM	4.375	
16	15	16	2:K150/100/4CF	ND-	ND-	5.000	
17	16	21	3:IPE600	NDM	NDM	4.375	
18	16	17	2:K150/100/4CF	ND-	ND-	5.000	
19	17	22	3:IPE600	NDM	NDM	4.375	
20	17	18	2:K150/100/4CF	ND-	ND-	5.000	
21	18	23	3:IPE600	NDM	NDM	4.375	
22	18	14	2:K150/100/4CF	ND-	ND-	5.000	
23	19	25	3:IPE600	NDM	NDM	4.375	
24	19	20	2:K150/100/4CF	ND-	ND-	5.000	
25	20	26	3:IPE600	NDM	NDM	4.375	
26	20	21	2:K150/100/4CF	ND-	ND-	5.000	
27	21	27	3:IPE600	NDM	NDM	4.375	
28	21	22	2:K150/100/4CF	ND-	ND-	5.000	
29	22	28	3:IPE600	NDM	NDM	4.375	
30	22	23	2:K150/100/4CF	ND-	ND-	5.000	
31	23	29	3:IPE600	NDM	NDM	4.375	
32	23	24	2:K150/100/4CF	ND-	ND-	5.000	

33	24	30	3:IPE600	NDM	NDM	4.375
34	25	3	3:IPE600	NDM	NDM	4.375
35	25	26	2:K150/100/4CF	ND-	ND-	5.000
36	26	12	3:IPE600	NDM	NDM	4.375
37	26	27	2:K150/100/4CF	ND-	ND-	5.000
38	27	10	3:IPE600	NDM	NDM	4.375
39	27	28	2:K150/100/4CF	ND-	ND-	5.000
40	28	8	3:IPE600	NDM	NDM	4.375
41	28	29	2:K150/100/4CF	ND-	ND-	5.000
42	29	6	3:IPE600	NDM	NDM	4.375
43	29	30	2:K150/100/4CF	ND-	ND-	5.000
44	30	4	3:IPE600	NDM	NDM	4.375
45	11	16	5:K150/150/5CF	ND-	ND-	6.644
46	16	22	5:K150/150/5CF	ND-	ND-	6.644
47	22	29	5:K150/150/5CF	ND-	ND-	6.644
48	29	4	5:K150/150/5CF	ND-	ND-	6.644
49	5	17	5:K150/150/5CF	ND-	ND-	6.644
50	17	21	5:K150/150/5CF	ND-	ND-	6.644
51	21	26	5:K150/150/5CF	ND-	ND-	6.644
52	26	3	5:K150/150/5CF	ND-	ND-	6.644

Onderdeel.....:

VASTE STEUNPUNTEN

Nr.	knoop	Kode	XZR 1=vast 0=vrij	Hoek
1	3	110		0.00
2	4	110		0.00
3	6	110		0.00
4	8	110		0.00
5	10	110		0.00
6	12	110		0.00

BELASTINGGEVALLEN

B.G.	Omschrijving	EGZ	Type
1	Permanente belasting	EGZ=-1.00	1
2	wind -y	EGZ=0.00	1 Permanente belasting
3	wind+y		7 Wind van links onderdruk A
4	sneeuw		22 Sneeuw A
5	Knik		0 Onbekend

BELASTINGEN

B.G:1 Permanente belasting

Eigen gewicht van alle staven is meegenomen in berekening. Richting:↓

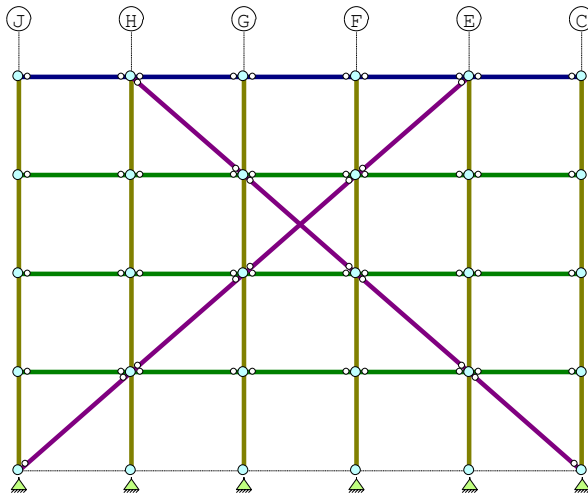

REACTIES

B.G:1 Permanente belasting

Kn.	X	Z	M
3	1.28	25.01	
4	-1.28	25.01	
6	0.01	26.80	
8	-0.01	26.96	
10	0.01	26.96	
12	-0.01	26.80	
	0.00	157.53	: Som van de reacties
	0.00	-157.53	: Som van de belastingen

Onderdeel.....:

BELASTINGEN

B.G:2 wind -y

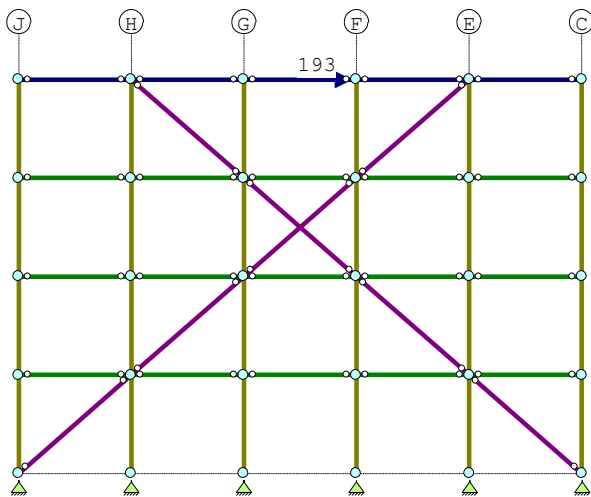

KNOOPBELASTINGEN

B.G:2 wind -y

Last	Knoop	Richting	waarde	Ψ_0	Ψ_1	Ψ_2
1	7	X	193.000			

REACTIES

B.G:2 wind -y

Kn.	X	Z	M
3	-97.70	-85.72	
4	-96.81	84.99	
6	0.36	85.99	
8	0.40	4.57	
10	0.44	-17.31	
12	0.32	-72.52	
	-193.00	0.00	: Som van de reacties
	193.00	0.00	: Som van de belastingen

BELASTINGEN

B.G:3 wind+y

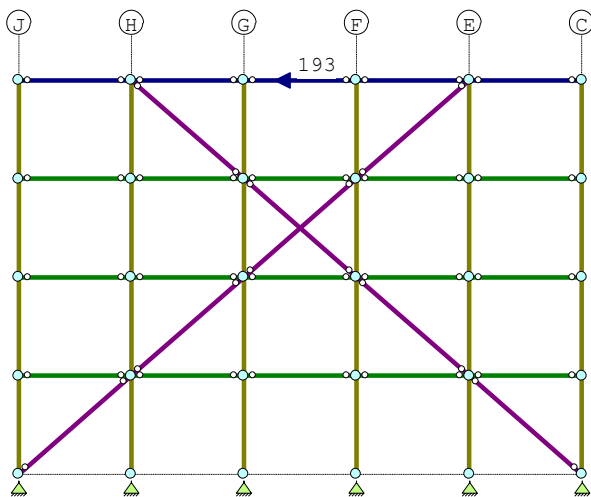

Onderdeel....:

KNOOPBELASTINGEN

B.G:3 wind+y

Last	Knoop	Richting	waarde	Ψ_0	Ψ_1	Ψ_2
1	7	X	-193.000	1.00	0.90	0.80

REACTIES

B.G:3 wind+y

Kn.	X	Z	M
3	97.70	85.72	
4	96.81	-84.99	
6	-0.36	-85.99	
8	-0.40	-4.57	
10	-0.44	17.31	
12	-0.32	72.52	
	193.00	0.00	: Som van de reacties
	-193.00	0.00	: Som van de belastingen

BELASTINGEN

B.G:4 sneeuw

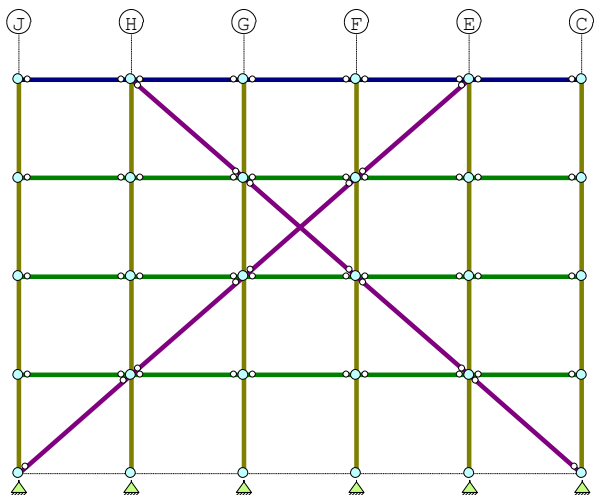

REACTIES

B.G:4 sneuw

Kn.	X	Z	M
3	0.00	0.00	
4	0.00	0.00	
6	0.00	0.00	
8	0.00	0.00	
10	0.00	0.00	
12	0.00	0.00	
	0.00	0.00	: Som van de reacties
	0.00	0.00	: Som van de belastingen

Onderdeel....:

BELASTINGEN

B.G:5 Knik

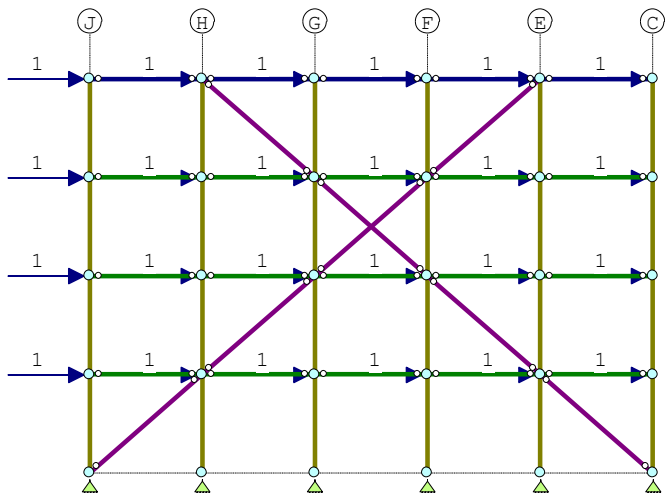

KNOOPBELASTINGEN

B.G:5 Knik

Last	Knoop	Richting	waarde	Ψ_0	Ψ_1	Ψ_2
1	1	X	1.000			
2	2	X	1.000			
3	5	X	1.000			
4	7	X	1.000			
5	9	X	1.000			
6	11	X	1.000			
7	13	X	1.000			
8	14	X	1.000			
9	15	X	1.000			
10	16	X	1.000			
11	17	X	1.000			
12	18	X	1.000			
13	19	X	1.000			
14	20	X	1.000			
15	21	X	1.000			
16	22	X	1.000			
17	23	X	1.000			
18	24	X	1.000			
19	25	X	1.000			
20	26	X	1.000			
21	27	X	1.000			

22	28 X	1.000
23	29 X	1.000
24	30 X	1.000

REACTIES

B.G:5 Knik

Kn.	X	Z	M
3	-11.73	-10.17	
4	-11.73	10.17	
6	-0.05	0.62	
8	-0.22	-0.22	
10	-0.22	0.22	
12	-0.05	-0.62	
	-24.00	0.00	: Som van de reacties
	24.00	0.00	: Som van de belastingen

Onderdeel....:

BELASTINGCOMBINATIES

BC	Type				
1	Fund.	1.35 $G_{k,1}$	+	1.35 $G_{k,2}$	
2	Fund.	1.20 $G_{k,1}$	+	1.50 $G_{k,2}$	
3	Fund.	0.90 $G_{k,1}$	+	1.50 $G_{k,2}$	
4	Fund.	0.90 $G_{k,1}$	+	0.90 $G_{k,2}$	
5	Fund.	1.35 $G_{k,1}$	+	1.35 $G_{k,2}$	+ 1.50 $\psi_0 Q_{k,3}$
6	Fund.	1.20 $G_{k,1}$	+	1.20 $G_{k,2}$	+ 1.50 $Q_{k,3}$
7	Fund.	0.90 $G_{k,1}$	+	0.90 $G_{k,2}$	+ 1.50 $\psi_0 Q_{k,3}$
8	Fund.	0.90 $G_{k,1}$	+	0.90 $G_{k,2}$	+ 1.50 $Q_{k,3}$
9	Kar.	1.00 $G_{k,1}$	+	1.00 $G_{k,2}$	+ 1.00 $Q_{k,3}$
10	Quas.	1.00 $G_{k,1}$	+	1.00 $G_{k,2}$	
11	Quas.	1.00 $G_{k,1}$	+	1.00 $G_{k,2}$	+ 1.00 $\psi_2 Q_{k,3}$
12	Freq.	1.00 $G_{k,1}$	+	1.00 $G_{k,2}$	
13	Freq.	1.00 $G_{k,1}$	+	1.00 $G_{k,2}$	+ 1.00 $\psi_1 Q_{k,3}$
14	Blij.	1.00 $G_{k,1}$	+	1.00 $G_{k,2}$	

GUNSTIGE WERKING PERMANENTE BELASTINGEN

BC	Staven met gunstige werking
1	Geen
2	Geen
3	Alle staven de factor:0.90, 1.50
4	Alle staven de factor:0.90
5	Geen
6	Geen
7	Alle staven de factor:0.90
8	Alle staven de factor:0.90

OMHULLENDE VAN DE FUNDAMENTELE COMBINATIES

MOMENTEN

Fundamentele combinatie

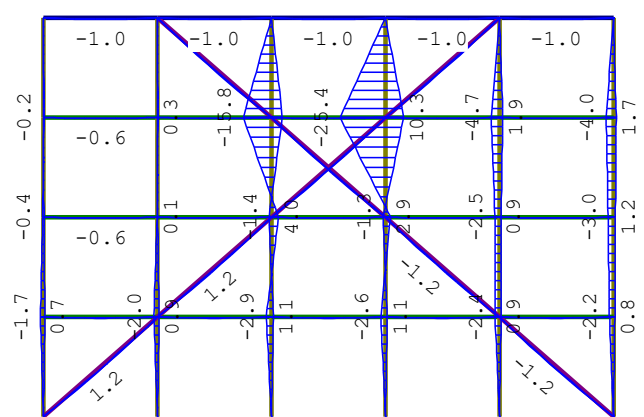

Onderdeel....:

DWARSKRACHTEN

Fundamentele combinatie

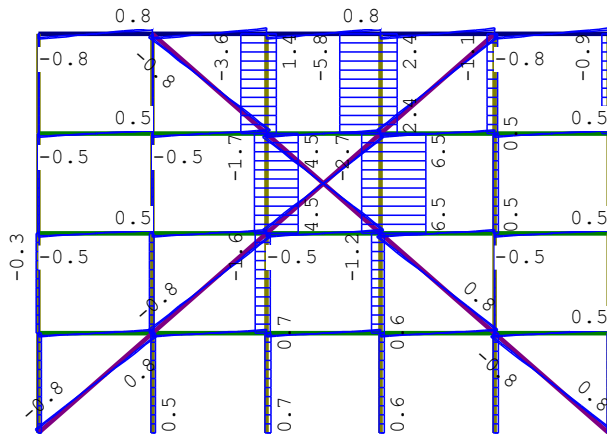

NORMAALKRACHTEN

Fundamentele combinatie

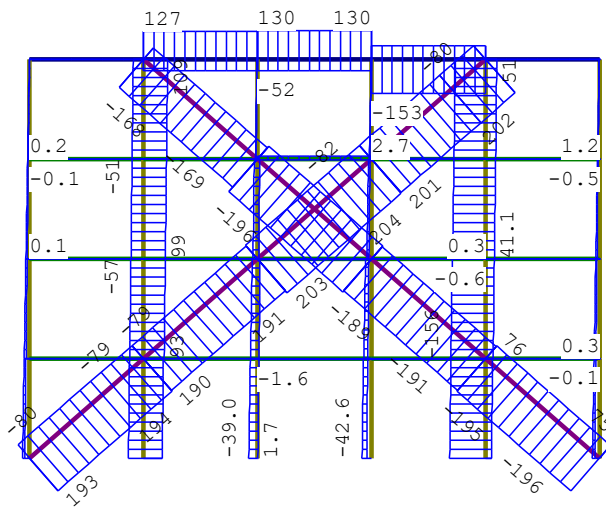

REACTIES

Fundamentele combinatie

Kn.	X-min	X-max	Z-min	Z-max	M-min	M-max
3	-145.41	59.77	-106.08	73.94		
4	-146.75	56.94	-28.49	157.50		
6	-0.21	0.56	-27.48	161.14		
8	-0.24	0.59	21.52	42.57		
10	-0.26	0.67	-1.70	38.99		
12	-0.20	0.47	-84.67	67.63		

Onderdeel.....:

OMHULLENDE VAN DE KARAKTERISTIEKE COMBINATIES

VERPLAATSINGEN

[mm]

Karakteristieke combinatie

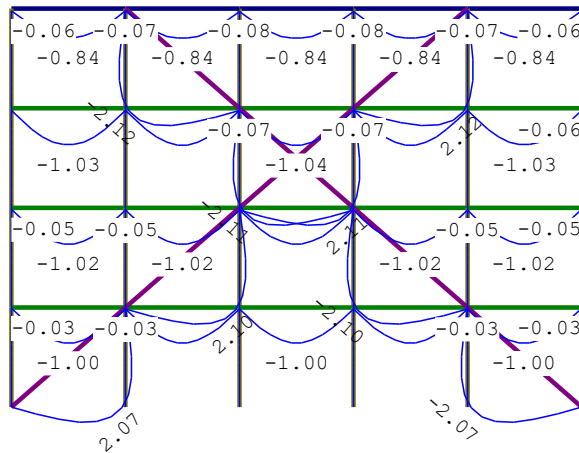

STAALPROFIELEN - ALGEMENE GEGEVENS

Stabiliteit: Classificatie gehele constructie: Ongeschoord
 Belastinggeval m.b.t. bepaling kniklengte: 5=Knik
 Aanpassing inkl. parameter C : Steunpunten
 Tweede-orde-effect:
 Aan te houden verhouding $n/(n-1)$
 voor steunmomenten en verplaatsingen: 1.10
 Doorbuiging en verplaatsing:
 Aantal bouwlagen: 1
 Gebouwtype: Overig
 Toel. horiz. verplaatsing gehele gebouw: $h/300$
 Kleinste gevelhoogte [m]: 0.0

PROFIEL/MATERIAAL

P/M nr.	Profielnaam	Vloeisp. [N/mm ²]	Productie methode	Min. drsn. klasse
1	HEA160	235	Gewalst	1
2	K150/100/4CF	235	Koudgevormd	1
3	IPE600	235	Gewalst	1
4	K160/160/5CF	235	Koudgevormd	1
5	K150/150/5CF	235	Koudgevormd	1

Partiële veiligheidsfactoren:

Gamma M;0 : 1.00 Gamma M;1 : 1.00

KNIKSTABILITEIT

Staafl	l_{sys} [m]	Classif. y sterke as	$l_{knik;y}$ [m]	Extra aanp. y [kN]	Classif. z zwakke as	$l_{knik;z}$ [m]	Extra aanp. z [kN]
1	5.000	Geschoord	5.000	0.0	Geschoord	5.000	0.0
2	4.375	Ongeschoord	4.380*	0.0	Geschoord	4.375	0.0
3	4.375	Ongeschoord	4.380*	0.0	Geschoord	4.375	0.0
4	5.000	Geschoord	5.000	0.0	Geschoord	5.000	0.0
5	4.375	Ongeschoord	4.380*	0.0	Geschoord	4.375	0.0
6	5.000	Geschoord	5.000	0.0	Geschoord	5.000	0.0
7	4.375	Ongeschoord	4.380*	0.0	Geschoord	4.375	0.0
8	5.000	Geschoord	5.000	0.0	Geschoord	5.000	0.0
9	4.375	Ongeschoord	4.380*	0.0	Geschoord	4.375	0.0
10	5.000	Geschoord	5.000	0.0	Geschoord	5.000	0.0
11	4.375	Ongeschoord	4.380*	0.0	Geschoord	4.375	0.0
12	4.375	Ongeschoord	4.380*	0.0	Geschoord	4.375	0.0
13	4.375	Ongeschoord	4.380*	0.0	Geschoord	4.375	0.0

Onderdeel....:

KNIKSTABILITEIT

Staafl	l_{sys} [m]	Classif. y sterke as	$l_{knik;y}$ [m]	Extra aanp. y [kN]	Classif. z zwakke as	$l_{knik;z}$ [m]	Extra aanp. z [kN]
14	5.000	Geschoord	5.000	0.0	Geschoord	5.000	0.0
15	4.375	Ongeschoord	4.380*	0.0	Geschoord	4.375	0.0
16	5.000	Geschoord	5.000	0.0	Geschoord	5.000	0.0
17	4.375	Ongeschoord	4.380*	0.0	Geschoord	4.375	0.0
18	5.000	Geschoord	5.000	0.0	Geschoord	5.000	0.0
19	4.375	Ongeschoord	4.380*	0.0	Geschoord	4.375	0.0
20	5.000	Geschoord	5.000	0.0	Geschoord	5.000	0.0
21	4.375	Ongeschoord	4.380*	0.0	Geschoord	4.375	0.0
22	5.000	Geschoord	5.000	0.0	Geschoord	5.000	0.0
23	4.375	Ongeschoord	4.380*	0.0	Geschoord	4.375	0.0
24	5.000	Geschoord	5.000	0.0	Geschoord	5.000	0.0
25	4.375	Ongeschoord	4.380*	0.0	Geschoord	4.375	0.0
26	5.000	Geschoord	5.000	0.0	Geschoord	5.000	0.0
27	4.375	Ongeschoord	4.380*	0.0	Geschoord	4.375	0.0

28	5.000	Geschoord	5.000	0.0	Geschoord	5.000	0.0
29	4.375	Ongeschoord	4.380*	4.4	Geschoord	4.375	0.0
30	5.000	Geschoord	5.000	0.0	Geschoord	5.000	0.0
31	4.375	Ongeschoord	4.380*	0.0	Geschoord	4.375	0.0
32	5.000	Geschoord	5.000	0.0	Geschoord	5.000	0.0
33	4.375	Ongeschoord	4.380*	0.0	Geschoord	4.375	0.0
34	4.375	Ongeschoord	4.380*	0.0	Geschoord	4.375	0.0
35	5.000	Geschoord	5.000	0.0	Geschoord	5.000	0.0
36	4.375	Ongeschoord	4.380*	0.0	Geschoord	4.375	0.0
37	5.000	Geschoord	5.000	0.0	Geschoord	5.000	0.0
38	4.375	Ongeschoord	4.380*	0.0	Geschoord	4.375	0.0
39	5.000	Geschoord	5.000	0.0	Geschoord	5.000	0.0
40	4.375	Ongeschoord	4.380*	0.0	Geschoord	4.375	0.0
41	5.000	Geschoord	5.000	0.0	Geschoord	5.000	0.0
42	4.375	Ongeschoord	4.380*	0.0	Geschoord	4.375	0.0
43	5.000	Geschoord	5.000	0.0	Geschoord	5.000	0.0
44	4.375	Ongeschoord	4.380*	0.0	Geschoord	4.375	0.0
45	6.644	Geschoord	6.644	0.0	Geschoord	6.644	0.0
46	6.644	Geschoord	6.644	0.0	Geschoord	6.644	0.0
47	6.644	Geschoord	6.644	0.0	Geschoord	6.644	0.0
48	6.644	Geschoord	6.644	0.0	Geschoord	6.644	0.0
49	6.644	Geschoord	6.644	0.0	Geschoord	6.644	0.0
50	6.644	Geschoord	6.644	0.0	Geschoord	6.644	0.0
51	6.644	Geschoord	6.644	0.0	Geschoord	6.644	0.0
52	6.644	Geschoord	6.644	0.0	Geschoord	6.644	0.0

* Door gebruiker gedefinieerde kniklengte

KIPSTABILITEIT

Staaft aangr.	Plts. aangr.		l gaffel [m]	Kipsteunafstanden [m]
1	1.0*h	boven:	5.00	5.000
		onder:		5.000
2	0.0*h	boven:	4.38	4.375
		onder:		4.375
3	1.0*h	boven:	4.38	4.375
		onder:		4.375
4	1.0*h	boven:	5.00	5.000
		onder:		5.000
5	0.0*h	boven:	4.38	4.375
		onder:		4.375
6	1.0*h	boven:	5.00	5.000
		onder:		5.000

Onderdeel....:

KIPSTABILITEIT

Staaft aangr.	Plts. aangr.		l gaffel [m]	Kipsteunafstanden [m]
7	0.0*h	boven:	4.38	4.375
		onder:		4.375
8	1.0*h	boven:	5.00	5.000
		onder:		5.000
9	0.0*h	boven:	4.38	4.375
		onder:		4.375
10	1.0*h	boven:	5.00	5.000
		onder:		5.000
11	0.0*h	boven:	4.38	4.375
		onder:		4.375
12	0.0*h	boven:	4.38	4.375
		onder:		4.375
13	1.0*h	boven:	4.38	4.375
		onder:		4.375
14	1.0*h	boven:	5.00	5.000
		onder:		5.000
15	0.0*h	boven:	4.38	4.375
		onder:		4.375
16	1.0*h	boven:	5.00	5.000
		onder:		5.000
17	0.0*h	boven:	4.38	4.375
		onder:		4.375
18	1.0*h	boven:	5.00	5.000
		onder:		5.000
19	0.0*h	boven:	4.38	4.375
		onder:		4.375
20	1.0*h	boven:	5.00	5.000
		onder:		5.000
21	0.0*h	boven:	4.38	4.375
		onder:		4.375
22	1.0*h	boven:	5.00	5.000
		onder:		5.000
23	0.0*h	boven:	4.38	4.375

24	1.0*h	onder:	4.375
		boven:	5.00 5.000
25	0.0*h	onder:	5.000
		boven:	4.38 4.375
		onder:	4.375
26	1.0*h	boven:	5.00 5.000
		onder:	5.000
27	0.0*h	boven:	4.38 4.375
		onder:	4.375
28	1.0*h	boven:	5.00 5.000
		onder:	5.000
29	0.0*h	boven:	4.38 4.375
		onder:	4.375
30	1.0*h	boven:	5.00 5.000
		onder:	5.000
31	0.0*h	boven:	4.38 4.375
		onder:	4.375
32	1.0*h	boven:	5.00 5.000
		onder:	5.000
33	1.0*h	boven:	4.38 4.375
		onder:	4.375
34	0.0*h	boven:	4.38 4.375
		onder:	4.375
35	1.0*h	boven:	5.00 5.000
		onder:	5.000

Onderdeel....:

KIPSTABILITEIT

Staafl	Plts. aangr.		1 gaffel [m]	Kipsteunafstanden [m]
36	0.0*h	boven:	4.38	4.375
		onder:		4.375
37	1.0*h	boven:	5.00	5.000
		onder:		5.000
38	0.0*h	boven:	4.38	4.375
		onder:		4.375
39	1.0*h	boven:	5.00	5.000
		onder:		5.000
40	0.0*h	boven:	4.38	4.375
		onder:		4.375
41	1.0*h	boven:	5.00	5.000
		onder:		5.000
42	0.0*h	boven:	4.38	4.375
		onder:		4.375
43	1.0*h	boven:	5.00	5.000
		onder:		5.000
44	1.0*h	boven:	4.38	4.375
		onder:		4.375
45	0.0*h	boven:	6.64	6.644
		onder:		6.644
46	0.0*h	boven:	6.64	6.644
		onder:		6.644
47	0.0*h	boven:	6.64	6.644
		onder:		6.644
48	0.0*h	boven:	6.64	6.644
		onder:		6.644
49	0.0*h	boven:	6.64	6.644
		onder:		6.644
50	0.0*h	boven:	6.64	6.644
		onder:		6.644
51	0.0*h	boven:	6.64	6.644
		onder:		6.644
52	0.0*h	boven:	6.64	6.644
		onder:		6.644

TOETSING SPANNINGEN

Staafl	P/M	BC	Sit	Kl	Plaats	Norm	Artikel	Formule	Hoogste toetsing U.C. [N/mm ²]	Opm.
1	4	1	1	1	My-max	EN3-1-1	6.2.9.1	(6.45+6.31y)	0.027	6
2	3				Staafl is onbelast					47,129,57
3	3				Staafl is onbelast					47,57
4	4	1	1	1	My-max	EN3-1-1	6.2.9.1	(6.45+6.31y)	0.027	6
5	3	2	1	4	Staafl	EN3-1-1	6.3.3	(6.62)	0.073	16 47,129
6	4	2	1	1	Staafl	EN3-1-1	6.3.3	(6.61)	0.364	86
7	3	2	1	1	Staafl	EN3-1-1	6.3.3	(6.62)	0.034	8 47
8	4	2	1	1	Begin	EN3-1-1	6.2.1(6)	N+D	0.186	44
9	3	2	1	1	Staafl	EN3-1-1	6.3.3	(6.62)	0.023	5 47
10	4	2	1	1	Begin	EN3-1-1	6.2.1(6)	N+D	0.181	43
11	3	3	1	1	Begin	EN3-1-1	6.2.1(6)	N+D	0.030	7
12	3				Staafl is onbelast					47,129,57
13	3	1	1	1	Staafl	EN3-1-1	6.3.3	(6.62)	0.012	3 47

14	2	1	1	1	My-max	EN3-1-1	6.2.9.1	(6.45+6.31y)	0.031	7
15	3	3	1	1	Begin	EN3-1-1	6.2.1(6)	N+D	0.028	7
16	2	1	1	1	My-max	EN3-1-1	6.2.9.1	(6.45+6.31y)	0.031	7
17	3	2	1	1	Begin	EN3-1-1	6.2.10	(6.45+6.31y)	0.021	5
18	2	7	1	1	Staaaf	EN3-1-1	6.3.3	(6.61)	0.037	9
19	3	2	1	1	Staaaf	EN3-1-1	6.3.3	(6.62)	0.039	9
20	2	1	1	1	My-max	EN3-1-1	6.2.9.1	(6.45+6.31y)	0.031	7

47

Onderdeel....:

TOETSING SPANNINGEN

Staaaf nr.	P/M	BC	Sit	Kl	Plaats	Norm	Artikel	Formule	Hoogste toetsing U.C. [N/mm ²]	Opm.
21	3	2	1	4	Staaaf	EN3-1-1	6.3.3	(6.62)	0.076	17
22	2	1	1	1	My-max	EN3-1-1	6.2.9.1	(6.45+6.31y)	0.031	7
23	3	1	1	4	Staaaf	EN3-1-1	6.3.3	(6.62)	0.013	3
24	2	1	1	1	My-max	EN3-1-1	6.2.9.1	(6.45+6.31y)	0.031	7
25	3	7	1	4	Staaaf	EN3-1-1	6.3.3	(6.62)	0.030	7
26	2	1	1	1	My-max	EN3-1-1	6.2.9.1	(6.45+6.31y)	0.031	7
27	3	7	1	4	Staaaf	EN3-1-1	6.3.3	(6.62)	0.016	4
28	2	1	1	1	Staaaf	EN3-1-1	6.3.3	(6.61)	0.039	9
29	3	1	1	4	Staaaf	EN3-1-1	6.3.3	(6.62)	0.020	4
30	2	1	1	1	My-max	EN3-1-1	6.2.9.1	(6.45+6.31y)	0.031	7
31	3	2	1	4	Staaaf	EN3-1-1	6.3.3	(6.62)	0.076	17
32	2	1	1	1	My-max	EN3-1-1	6.2.5	(6.12y)	0.031	7
33	3	1	1	4	Staaaf	EN3-1-1	6.3.3	(6.62)	0.015	3
34	3	1	1	4	Staaaf	EN3-1-1	6.3.3	(6.62)	0.017	4
35	2	1	1	1	My-max	EN3-1-1	6.2.9.1	(6.45+6.31y)	0.031	7
36	3	7	1	4	Staaaf	EN3-1-1	6.3.3	(6.62)	0.033	7
37	2	1	1	1	My-max	EN3-1-1	6.2.9.1	(6.45+6.31y)	0.031	7
38	3	5	1	4	Staaaf	EN3-1-1	6.3.3	(6.62)	0.019	4
39	2	1	1	1	Staaaf	EN3-1-1	6.3.3	(6.61)	0.033	8
40	3	1	1	4	Staaaf	EN3-1-1	6.3.3	(6.62)	0.023	5
41	2	1	1	1	Staaaf	EN3-1-1	6.3.3	(6.61)	0.039	9
42	3	2	1	4	Staaaf	EN3-1-1	6.3.3	(6.62)	0.079	18
43	2	1	1	1	My-max	EN3-1-1	6.2.9.1	(6.45+6.31y)	0.031	7
44	3	1	1	4	Staaaf	EN3-1-1	6.3.3	(6.62)	0.017	4
45	5	2	1	1	Staaaf	EN3-1-1	6.3.3	(6.61)	0.630	148
46	5	2	1	1	Staaaf	EN3-1-1	6.3.3	(6.61)	0.728	171
47	5	2	1	1	Staaaf	EN3-1-1	6.3.3	(6.61)	0.705	166
48	5	2	1	1	Staaaf	EN3-1-1	6.3.3	(6.61)	0.726	171
49	5	7	1	1	Staaaf	EN3-1-1	6.3.3	(6.61)	0.308	72
50	5	7	1	1	Staaaf	EN3-1-1	6.3.3	(6.61)	0.315	74
51	5	7	1	1	Staaaf	EN3-1-1	6.3.3	(6.61)	0.299	70
52	5	7	1	1	Staaaf	EN3-1-1	6.3.3	(6.61)	0.305	72

Opmerkingen:

- [47] Bij verlopende normaalkracht wordt de grootste drukkracht genomen.
- [57] Staaaf is (nagenoeg) onbelast.
- [129] Bij berekening van klasse 4 profielen is gebruik gemaakt van de spanningsreductiemethode.

TOETSING DOORBUIGING

Staaaf	Soort	Mtg	Lengte [m]	Overst I	Overst J	Zeeg [mm]	u _{tot} [mm]	BC	Sit	u [mm]	Toelaatbaar [mm]	*1
1	Dak	db	5.00	N	N	0.0	-0.8	9	1 Eind	-0.8	-20.0	0.004
		ss						9	1 Bijk	-0.4	-40.0	2*0.004
4	Dak	db	5.00	N	N	0.0	-0.8	9	1 Eind	-0.8	-20.0	0.004
		ss						9	1 Bijk	0.5	-40.0	2*0.004
6	Dak	db	5.00	N	N	0.0	-0.8	9	1 Eind	-0.8	-20.0	0.004
		ss						9	1 Bijk	-0.5	-40.0	2*0.004
8	Dak	db	5.00	N	N	0.0	-0.8	9	1 Eind	-0.8	-20.0	0.004
		ss						9	1 Bijk	0.1	-40.0	2*0.004
10	Dak	db	5.00	N	N	0.0	-0.8	9	1 Eind	-0.8	-20.0	0.004
		ss						9	1 Bijk	0.4	-40.0	2*0.004
14	Vloer	db	5.00	N	N	0.0	-1.1	9	1 Eind	-1.1	±20.0	0.004
		ss						9	1 Bijk	-0.3	±30.0	2*0.003
16	Vloer	db	5.00	N	N	0.0	-1.1	9	1 Eind	-1.1	±20.0	0.004
		ss						9	1 Bijk	0.3	±30.0	2*0.003
18	Vloer	db	5.00	N	N	0.0	-1.1	9	1 Eind	-1.1	±20.0	0.004
		ss						9	1 Bijk	0.1	±30.0	2*0.003
20	Vloer	db	5.00	N	N	0.0	-1.1	9	1 Eind	-1.1	±20.0	0.004
		ss						9	1 Bijk	-0.4	±30.0	2*0.003

Onderdeel....:

TOETSING DOORBUIGING

Staaaf	Soort	Mtg	Lengte [m]	Overst I	Overst J	Zeeg [mm]	u _{tot} [mm]	BC	Sit	u [mm]	Toelaatbaar [mm]	*1
22	Vloer	db	5.00	N	N	0.0	-1.1	9	1 Eind	-1.1	±20.0	0.004
		ss						9	1 Bijk	0.4	±30.0	2*0.003
24	Vloer	db	5.00	N	N	0.0	-1.1	9	1 Eind	-1.1	±20.0	0.004

26	Vloer	ss	5.00	N	N	0.0	-1.1	9	1	Bijk	-0.2	±30.0	2*0.003
		db						9	1	Eind	-1.1	±20.0	0.004
28	Vloer	ss	5.00	N	N	0.0	-1.1	9	1	Bijk	0.2	±30.0	2*0.003
		db						9	1	Eind	-1.1	±20.0	0.004
30	Vloer	ss	5.00	N	N	0.0	-1.1	9	1	Bijk	0.1	±30.0	2*0.003
		db						9	1	Eind	-1.1	±20.0	0.004
32	Vloer	ss	5.00	N	N	0.0	-1.1	9	1	Bijk	-0.2	±30.0	2*0.003
		db						9	1	Eind	-1.1	±20.0	0.004
35	Vloer	ss	5.00	N	N	0.0	-1.1	9	1	Bijk	0.3	±30.0	2*0.003
		db						9	1	Eind	-1.1	±20.0	0.004
37	Vloer	ss	5.00	N	N	0.0	-1.1	9	1	Bijk	-0.1	±30.0	2*0.003
		db						9	1	Eind	-1.1	±20.0	0.004
39	Vloer	ss	5.00	N	N	0.0	-1.1	9	1	Bijk	0.1	±30.0	2*0.003
		db						9	1	Eind	-1.1	±20.0	0.004
41	Vloer	ss	5.00	N	N	0.0	-1.1	9	1	Bijk	0.0	±30.0	2*0.003
		db						9	1	Eind	-1.1	±20.0	0.004
43	Vloer	ss	5.00	N	N	0.0	-1.1	9	1	Bijk	-0.1	±30.0	2*0.003
		db						9	1	Eind	-1.1	±20.0	0.004
		ss						9	1	Bijk	0.1	±30.0	2*0.003

TOETSING HORIZONTALE VERPLAATSING

Staaft	BC	Sit	Lengte [m]	u _{e i n d} [mm]	Toelaatbaar [mm]	Maatgevend [h/]
2	9	1	4.375	0.0	14.6	300 scheefstand
3	9	1	4.375	-0.0	14.6	300 scheefstand
5	9	1	4.375	-0.0	14.6	300 scheefstand
7	9	1	4.375	-0.0	14.6	300 scheefstand
9	9	1	4.375	0.0	14.6	300 scheefstand
11	9	1	4.375	0.0	14.6	300 scheefstand
12	9	1	4.375	-0.0	14.6	300 scheefstand
13	9	1	4.375	0.0	14.6	300 scheefstand
15	9	1	4.375	-0.0	14.6	300 scheefstand
17	9	1	4.375	0.0	14.6	300 scheefstand
19	9	1	4.375	-0.0	14.6	300 scheefstand
21	9	1	4.375	0.0	14.6	300 scheefstand
23	9	1	4.375	-0.0	14.6	300 scheefstand
25	9	1	4.375	-0.0	14.6	300 scheefstand
27	9	1	4.375	-0.0	14.6	300 scheefstand
29	9	1	4.375	0.0	14.6	300 scheefstand
31	9	1	4.375	0.0	14.6	300 scheefstand
33	9	1	4.375	0.0	14.6	300 scheefstand
34	9	1	4.375	-0.0	14.6	300 scheefstand
36	9	1	4.375	-0.0	14.6	300 scheefstand
38	9	1	4.375	-0.0	14.6	300 scheefstand
40	9	1	4.375	0.0	14.6	300 scheefstand
42	9	1	4.375	0.0	14.6	300 scheefstand
44	9	1	4.375	0.0	14.6	300 scheefstand

A - 5 Facade 9

Technosoft Raamwerken release 6.79a

17 jan 2024

Project.....: MM20152 - as 9
 Dimensies....: kN;m;rad (tenzij anders aangegeven)
 Bestand.....: K:\Projecten\MM20152\10 Constructeur\03 DO - Definitief
 Ontwerp\reacties\facade9.rww

Belastingbreedte.: 5.000
 Rekenmodel.....: 1e-orde-elastisch.
 Theorie voor de bepaling van de krachtsverdeling:
 Geometrisch lineair.
 Fysisch lineair.

Gunstige werking van de permanente belasting wordt automatisch verwerkt.

Toegepaste normen volgens Eurocode met Nederlandse NB

Belastingen	NEN-EN 1990:2002	C2:2010,A1:2019	NB:2019(nl)
	NEN-EN 1991-1-1:2002	C1/C11:2019	NB:2019(nl)
Staal	NEN-EN 1993-1-1:2006	C2:2011,A1:2016	NB:2016(nl)

GEOMETRIE

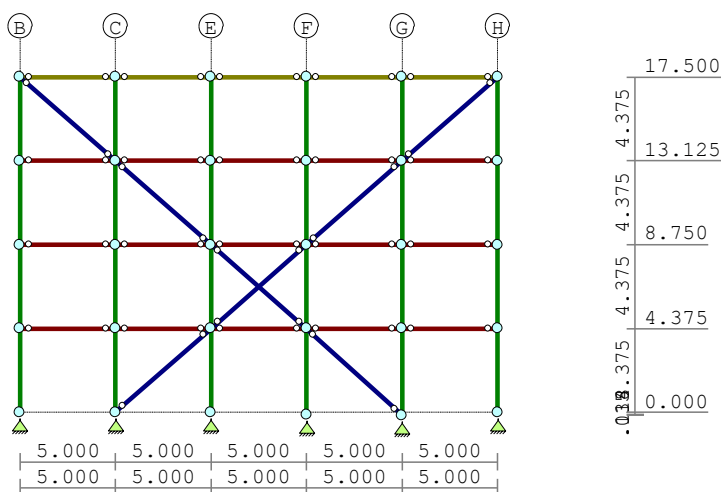

STRAMIENLIJNEN

Nr.	Naam	X	Z-min	Z-max
1	B	0.000	-0.153	17.500
2	C	5.000	-0.153	17.500
3	E	10.000	-0.153	17.500
4	F	15.000	-0.153	17.500
5	G	20.000	-0.153	17.500
6	H	25.000	-0.153	17.500

NIVEAUS

Nr.	Z	X-min	X-max
1	0.000	0.000	25.000
2	17.500	0.000	25.000
3	4.375	0.000	25.000
4	8.750	0.000	25.000
5	13.125	0.000	25.000

Onderdeel.....:

MATERIALEN

Mt	Kwaliteit	E-modulus[N/mm2]	S.G.	Pois.	Uitz. coëff
1	S235	210000	78.5	0.30	1.2000e-05

PROFIELEN [mm]

Prof.	Omschrijving	Materiaal	Oppervlak	Traagheid	Vormf.
1	K150/100/4CF	1:S235	1.8948e+03	5.9460e+06	0.00
2	IPE600	1:S235	1.5600e+04	9.2080e+08	0.00
3	K160/160/5CF	1:S235	3.0356e+03	1.2024e+07	0.00
4	K150/150/5CF	1:S235	2.8356e+03	9.8212e+06	0.00

PROFIELEN vervolg [mm]

Prof.	Staaftype	Breedte	Hoogte	e	Type	b1	h1	b2	h2
1	0:Normaal	100	150	75.0					
2	0:Normaal	220	600	300.0					
3	0:Normaal	160	160	80.0					
4	0:Normaal	150	150	75.0					

PROFIELVORMEN [mm]

1 K150/100/4CF



2 IPE600



3 K160/160/5CF



4 K150/150/5CF



KNOPEN

Knoop	X	Z	Knoop	X	Z
1	0.000	17.500	6	20.000	-0.153
2	25.000	17.500	7	15.000	17.500
3	0.000	0.000	8	15.000	-0.118
4	25.000	0.000	9	10.000	17.500
5	20.000	17.500	10	10.000	0.000
11	5.000	17.500	16	10.000	13.125
12	5.000	0.000	17	15.000	13.125
13	0.000	13.125	18	20.000	13.125
14	25.000	13.125	19	0.000	8.750
15	5.000	13.125	20	5.000	8.750
21	10.000	8.750	26	5.000	4.375
22	15.000	8.750	27	10.000	4.375
23	20.000	8.750	28	15.000	4.375
24	25.000	8.750	29	20.000	4.375
25	0.000	4.375	30	25.000	4.375

STAVEN

St.	ki	kj	Profiel	Aansl.i	Aansl.j	Lengte	Opm.
1	1	11	3:K160/160/5CF	ND-	ND-	5.000	
2	1	13	2:IPE600	NDM	NDM	4.375	
3	2	14	2:IPE600	NDM	NDM	4.375	
4	5	2	3:K160/160/5CF	ND-	ND-	5.000	
5	5	18	2:IPE600	NDM	NDM	4.375	
6	7	5	3:K160/160/5CF	ND-	ND-	5.000	
7	7	17	2:IPE600	NDM	NDM	4.375	

Onderdeel.....:

STAVEN

St.	ki	kj	Profiel	Aansl.i	Aansl.j	Lengte	Opm.
8	9	7	3:K160/160/5CF	ND-	ND-	5.000	
9	9	16	2:IPE600	NDM	NDM	4.375	
10	11	9	3:K160/160/5CF	ND-	ND-	5.000	
11	11	15	2:IPE600	NDM	NDM	4.375	
12	13	19	2:IPE600	NDM	NDM	4.375	
13	14	24	2:IPE600	NDM	NDM	4.375	
14	13	15	1:K150/100/4CF	ND-	ND-	5.000	
15	15	20	2:IPE600	NDM	NDM	4.375	
16	15	16	1:K150/100/4CF	ND-	ND-	5.000	
17	16	21	2:IPE600	NDM	NDM	4.375	
18	16	17	1:K150/100/4CF	ND-	ND-	5.000	
19	17	22	2:IPE600	NDM	NDM	4.375	
20	17	18	1:K150/100/4CF	ND-	ND-	5.000	
21	18	23	2:IPE600	NDM	NDM	4.375	
22	18	14	1:K150/100/4CF	ND-	ND-	5.000	
23	19	25	2:IPE600	NDM	NDM	4.375	
24	19	20	1:K150/100/4CF	ND-	ND-	5.000	
25	20	26	2:IPE600	NDM	NDM	4.375	
26	20	21	1:K150/100/4CF	ND-	ND-	5.000	
27	21	27	2:IPE600	NDM	NDM	4.375	
28	21	22	1:K150/100/4CF	ND-	ND-	5.000	
29	22	28	2:IPE600	NDM	NDM	4.375	
30	22	23	1:K150/100/4CF	ND-	ND-	5.000	
31	23	29	2:IPE600	NDM	NDM	4.375	
32	23	24	1:K150/100/4CF	ND-	ND-	5.000	
33	24	30	2:IPE600	NDM	NDM	4.375	
34	25	3	2:IPE600	NDM	NDM	4.375	
35	25	26	1:K150/100/4CF	ND-	ND-	5.000	

36	26	12	2:IPE600	NDM	NDM	4.375
37	26	27	1:K150/100/4CF	ND-	ND-	5.000
38	27	10	2:IPE600	NDM	NDM	4.375
39	27	28	1:K150/100/4CF	ND-	ND-	5.000
40	28	8	2:IPE600	NDM	NDM	4.493
41	28	29	1:K150/100/4CF	ND-	ND-	5.000
42	29	6	2:IPE600	NDM	NDM	4.528
43	29	30	1:K150/100/4CF	ND-	ND-	5.000
44	30	4	2:IPE600	NDM	NDM	4.375
45	1	15	4:K150/150/5CF	ND-	ND-	6.644
46	15	21	4:K150/150/5CF	ND-	ND-	6.644
47	21	28	4:K150/150/5CF	ND-	ND-	6.644
48	28	6	4:K150/150/5CF	ND-	ND-	6.746
49	12	27	4:K150/150/5CF	ND-	ND-	6.644
50	27	22	4:K150/150/5CF	ND-	ND-	6.644
51	22	18	4:K150/150/5CF	ND-	ND-	6.644
52	18	2	4:K150/150/5CF	ND-	ND-	6.644

VASTE STEUNPUNTEN

Nr. knoop	Kode	XZR	1=vast 0=vrij	Hoek
1	3	110		0.00
2	4	110		0.00
3	6	110		0.00
4	8	110		0.00
5	10	110		0.00
6	12	110		0.00

Onderdeel.....:

BELASTINGGEVALLEN

B.G.	Omschrijving	EGZ	Type
1	Permanente belasting	EGZ=-1.00	1
2	wind -y	EGZ=0.00	1 Permanente belasting
3	Knik		0 Onbekend
4	sneuw		22 Sneeuw A
5	wind+y		7 Wind van links onderdruk A

BELASTINGEN

B.G:1 Permanente belasting

Eigen gewicht van alle staven is meegenomen in berekening. Richting:↓

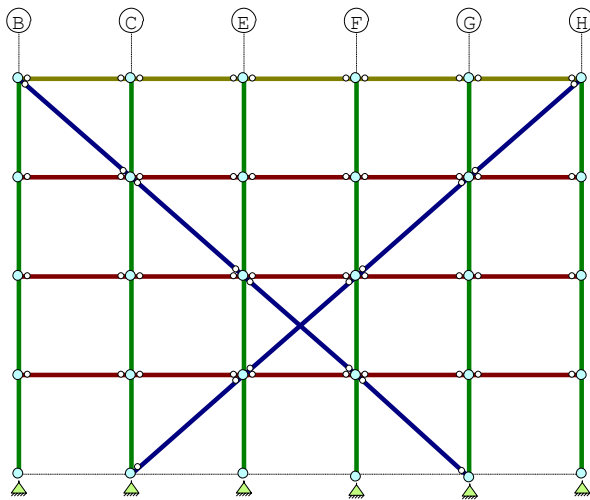

REACTIES

B.G:1 Permanente belasting

Kn.	X	Z	M
3	-0.01	23.81	
4	0.02	23.82	
6	-1.36	28.18	
8	0.03	27.10	
10	-0.02	27.03	
12	1.35	27.94	
	0.00	157.88	: Som van de reacties
	0.00	-157.88	: Som van de belastingen

Onderdeel.....:

BELASTINGEN

B.G:2 wind -y

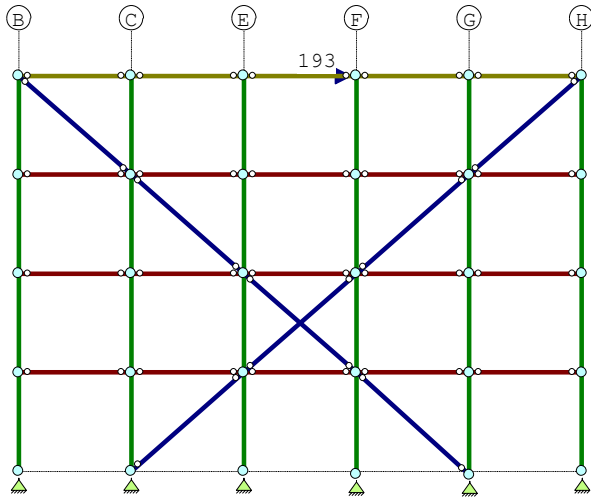

KNOOPBELASTINGEN

B.G:2 wind -y

Last	Knoop	Richting	waarde	Ψ_0	Ψ_1	Ψ_2
1	7	X	193.000			

REACTIES

B.G:2 wind -y

Kn.	X	Z	M
3	-0.11	-73.00	
4	-0.17	84.11	
6	-94.23	94.43	
8	0.05	-8.32	
10	-0.17	2.30	
12	-98.37	-99.52	
	-193.00	0.00	: Som van de reacties
	193.00	0.00	: Som van de belastingen

BELASTINGEN

B.G:3 Knik

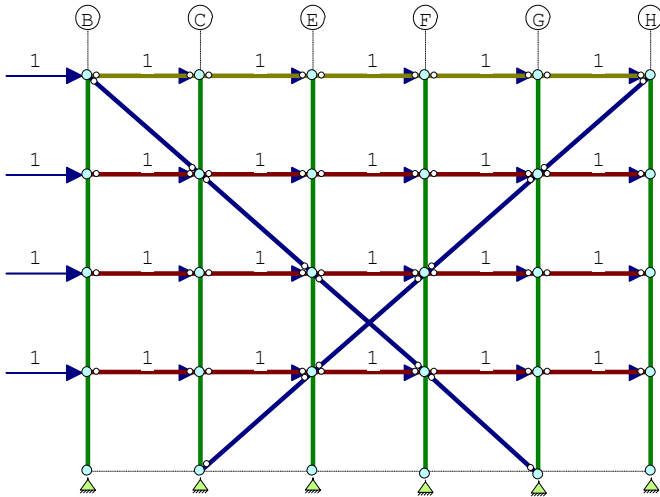

Onderdeel....:

KNOOPBELASTINGEN

B.G:3 Knik

Last	Knoop	Richting	waarde	Ψ_0	Ψ_1	Ψ_2
1	1	X	1.000			
2	2	X	1.000			
3	5	X	1.000			
4	7	X	1.000			
5	9	X	1.000			
6	11	X	1.000			
7	13	X	1.000			
8	14	X	1.000			
9	15	X	1.000			
10	16	X	1.000			
11	17	X	1.000			
12	18	X	1.000			
13	19	X	1.000			
14	20	X	1.000			
15	21	X	1.000			
16	22	X	1.000			

17	23 X	1.000
18	24 X	1.000
19	25 X	1.000
20	26 X	1.000
21	27 X	1.000
22	28 X	1.000
23	29 X	1.000
24	30 X	1.000

REACTIES

B.G:3 Knik

Kn.	X	Z	M
3	-0.21	-2.88	
4	-0.22	2.89	
6	-11.43	12.74	
8	-0.13	0.20	
10	-0.14	-0.18	
12	-11.86	-12.76	
	-24.00	0.00	: Som van de reacties
	24.00	0.00	: Som van de belastingen

BELASTINGEN

B.G:4 sneuw

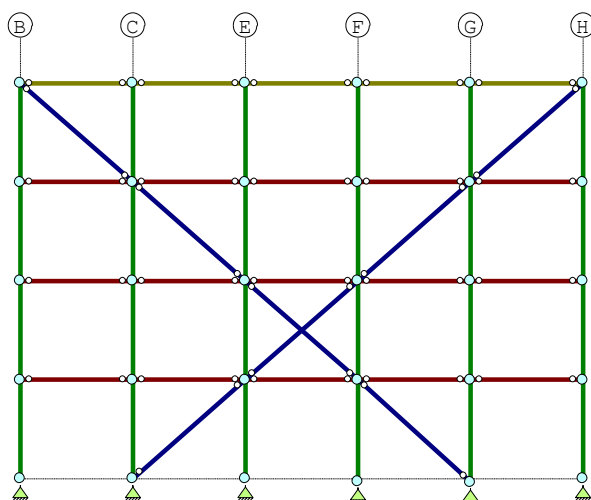

Onderdeel....:

REACTIES

B.G:4 sneuw

Kn.	X	Z	M
3	0.00	0.00	
4	0.00	0.00	
6	0.00	0.00	
8	0.00	0.00	
10	0.00	0.00	
12	0.00	0.00	
	0.00	0.00	: Som van de reacties
	0.00	0.00	: Som van de belastingen

BELASTINGEN

B.G:5 windty

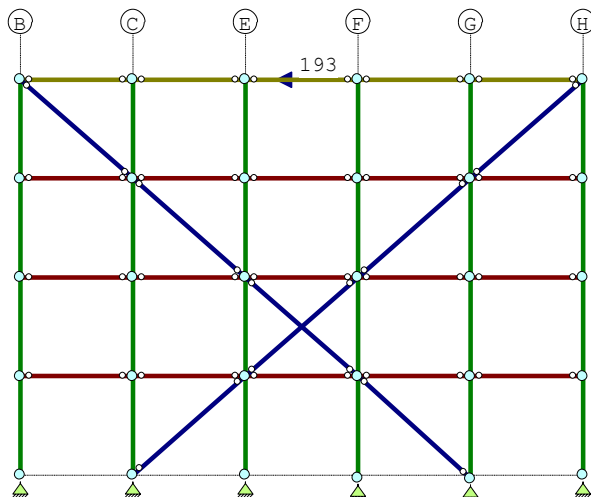

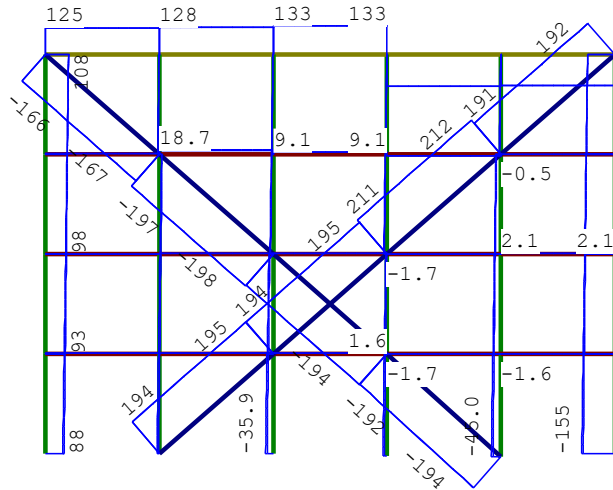

REACTIES

Fundamentele combinatie

Kn.	X-min	X-max	Z-min	Z-max	M-min	M-max
3	-0.18	-0.18	-88.06	-80.92		
4	-0.24	-0.24	147.60	154.75		
6	-142.97	-142.56	167.01	175.46		
8	0.09	0.10	11.91	20.04		
10	-0.28	-0.28	27.78	35.89		
12	-146.33	-145.93	-124.14	-115.76		

OMHULLENDE VAN DE KARAKTERISTIEKE COMBINATIES

VERPLAATSINGEN

[mm]

Karakteristieke combinatie

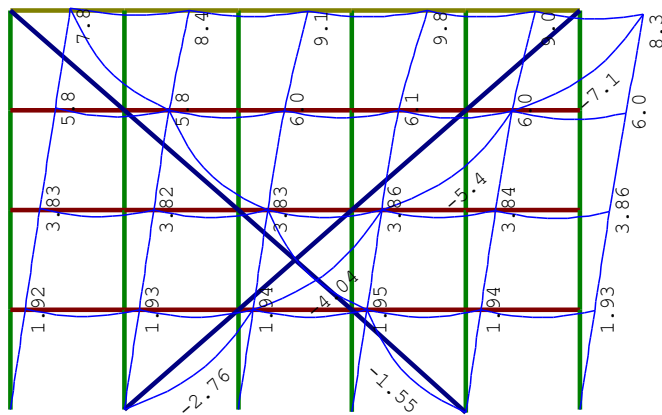

Onderdeel....:

STAALPROFIELEN - ALGEMENE GEGEVENS

Stabiliteit: Classificatie gehele constructie: Ongeschoord
 Belastinggeval m.b.t. bepaling kniklengte: 3=Knik
 Aanpassing inkl. parameter C : Steunpunten
 Tweede-orde-effect:
 Aan te houden verhouding n/(n-1)
 voor steunmomenten en verplaatsingen: 1.10
 Doorbuiging en verplaatsing:
 Aantal bouwlagen: 1
 Gebouwtype: Overig
 Toel. horiz. verplaatsing gehele gebouw: h/300
 Kleinste gevelhoogte [m]: 0.0

PROFIEL/MATERIAAL

P/M nr.	Profielnaam	Vloeisp. [N/mm ²]	Productie methode	Min. drsn. klasse
1	K150/100/4CF	235	Koudgevoormd	1
2	IPE600	235	Gewalst	1
3	K160/160/5CF	235	Koudgevoormd	1
4	K150/150/5CF	235	Koudgevoormd	1

Partiële veiligheidsfactoren:

Gamma M;0 : 1.00 Gamma M;1 : 1.00

KNIKSTABILITEIT

Extra

Extra

Staaft	l_{sys} [m]	Classif. y sterke as	$l_{knik;y}$ [m]	aanp. y [kN]	Classif. z zwakke as	$l_{knik;z}$ [m]	aanp. z [kN]
1	5.000	Geschoord	5.000	0.0	Geschoord	5.000	0.0
2	4.375	Ongeschoord	4.380*	0.0	Geschoord	4.375	0.0
3	4.375	Ongeschoord	4.380*	0.0	Geschoord	4.375	0.0
4	5.000	Geschoord	5.000	0.0	Geschoord	5.000	0.0
5	4.375	Ongeschoord	4.380*	0.0	Geschoord	4.375	0.0
6	5.000	Geschoord	5.000	0.0	Geschoord	5.000	0.0
7	4.375	Ongeschoord	4.380*	0.0	Geschoord	4.375	0.0
8	5.000	Geschoord	5.000	0.0	Geschoord	5.000	0.0
9	4.375	Ongeschoord	4.380*	0.0	Geschoord	4.375	0.0
10	5.000	Geschoord	5.000	0.0	Geschoord	5.000	0.0
11	4.375	Ongeschoord	4.380*	0.0	Geschoord	4.375	0.0
12	4.375	Ongeschoord	4.380*	0.0	Geschoord	4.375	0.0
13	4.375	Ongeschoord	4.380*	0.0	Geschoord	4.375	0.0
14	5.000	Geschoord	5.000	0.0	Geschoord	5.000	0.0
15	4.375	Ongeschoord	4.380*	0.0	Geschoord	4.375	0.0
16	5.000	Geschoord	5.000	0.0	Geschoord	5.000	0.0
17	4.375	Ongeschoord	4.380*	0.0	Geschoord	4.375	0.0
18	5.000	Geschoord	5.000	0.0	Geschoord	5.000	0.0
19	4.375	Ongeschoord	4.380*	0.0	Geschoord	4.375	0.0
20	5.000	Geschoord	5.000	0.0	Geschoord	5.000	0.0
21	4.375	Ongeschoord	4.380*	0.0	Geschoord	4.375	0.0
22	5.000	Geschoord	5.000	0.0	Geschoord	5.000	0.0
23	4.375	Ongeschoord	4.380*	0.0	Geschoord	4.375	0.0
24	5.000	Geschoord	5.000	0.0	Geschoord	5.000	0.0
25	4.375	Ongeschoord	4.380*	0.0	Geschoord	4.375	0.0
26	5.000	Geschoord	5.000	0.0	Geschoord	5.000	0.0
27	4.375	Ongeschoord	4.380*	0.0	Geschoord	4.375	0.0
28	5.000	Geschoord	5.000	0.0	Geschoord	5.000	0.0
29	4.375	Ongeschoord	4.380*	0.0	Geschoord	4.375	0.0
30	5.000	Geschoord	5.000	0.0	Geschoord	5.000	0.0
31	4.375	Ongeschoord	4.380*	0.0	Geschoord	4.375	0.0
32	5.000	Geschoord	5.000	0.0	Geschoord	5.000	0.0
33	4.375	Ongeschoord	4.380*	0.0	Geschoord	4.375	0.0
34	4.375	Ongeschoord	4.380*	0.0	Geschoord	4.375	0.0
35	5.000	Geschoord	5.000	0.0	Geschoord	5.000	0.0

Onderdeel.....:

KNIKSTABILITEIT							
Staaft	l_{sys} [m]	Classif. y sterke as	$l_{knik;y}$ [m]	Extra aanp. y [kN]	Classif. z zwakke as	$l_{knik;z}$ [m]	Extra aanp. z [kN]
36	4.375	Ongeschoord	4.380*	0.0	Geschoord	4.375	0.0
37	5.000	Geschoord	5.000	0.0	Geschoord	5.000	0.0
38	4.375	Ongeschoord	4.380*	0.0	Geschoord	4.375	0.0
39	5.000	Geschoord	5.000	0.0	Geschoord	5.000	0.0
40	4.493	Ongeschoord	4.490*	0.0	Geschoord	4.493	0.0
41	5.000	Geschoord	5.000	0.0	Geschoord	5.000	0.0
42	4.528	Ongeschoord	4.530*	0.0	Geschoord	4.528	0.0
43	5.000	Geschoord	5.000	0.0	Geschoord	5.000	0.0
44	4.375	Ongeschoord	4.380*	0.0	Geschoord	4.375	0.0
45	6.644	Geschoord	6.644	0.0	Geschoord	6.644	0.0
46	6.644	Geschoord	6.644	0.0	Geschoord	6.644	0.0
47	6.644	Geschoord	6.644	0.0	Geschoord	6.644	0.0
48	6.746	Geschoord	6.746	0.0	Geschoord	6.746	0.0
49	6.644	Geschoord	6.644	0.0	Geschoord	6.644	0.0
50	6.644	Geschoord	6.644	0.0	Geschoord	6.644	0.0
51	6.644	Geschoord	6.644	0.0	Geschoord	6.644	0.0
52	6.644	Geschoord	6.644	0.0	Geschoord	6.644	0.0

* Door gebruiker gedefinieerde kniklengte

KIPSTABILITEIT				
Staaft	Plts. aangr.	l gaffel [m]	Kipsteunafstanden [m]	
1	1.0*h	boven:	5.00	5.000
		onder:		5.000
2	0.0*h	boven:	4.38	4.375
		onder:		4.375
3	1.0*h	boven:	4.38	4.375
		onder:		4.375
4	1.0*h	boven:	5.00	5.000
		onder:		5.000
5	0.0*h	boven:	4.38	4.375
		onder:		4.375
6	1.0*h	boven:	5.00	5.000
		onder:		5.000
7	0.0*h	boven:	4.38	4.375
		onder:		4.375

8	1.0*h	boven:	5.00	5.000
		onder:		5.000
9	0.0*h	boven:	4.38	4.375
		onder:		4.375
10	1.0*h	boven:	5.00	5.000
		onder:		5.000
11	0.0*h	boven:	4.38	4.375
		onder:		4.375
12	0.0*h	boven:	4.38	4.375
		onder:		4.375
13	1.0*h	boven:	4.38	4.375
		onder:		4.375
14	1.0*h	boven:	5.00	5.000
		onder:		5.000
15	0.0*h	boven:	4.38	4.375
		onder:		4.375
16	1.0*h	boven:	5.00	5.000
		onder:		5.000
17	0.0*h	boven:	4.38	4.375
		onder:		4.375
18	1.0*h	boven:	5.00	5.000
		onder:		5.000

Onderdeel.....:

KIPSTABILITEIT

Staaft	Plts.		l gaffel	Kipsteunafstanden
aangr.			[m]	[m]
19	0.0*h	boven:	4.38	4.375
		onder:		4.375
20	1.0*h	boven:	5.00	5.000
		onder:		5.000
21	0.0*h	boven:	4.38	4.375
		onder:		4.375
22	1.0*h	boven:	5.00	5.000
		onder:		5.000
23	0.0*h	boven:	4.38	4.375
		onder:		4.375
24	1.0*h	boven:	5.00	5.000
		onder:		5.000
25	0.0*h	boven:	4.38	4.375
		onder:		4.375
26	1.0*h	boven:	5.00	5.000
		onder:		5.000
27	0.0*h	boven:	4.38	4.375
		onder:		4.375
28	1.0*h	boven:	5.00	5.000
		onder:		5.000
29	0.0*h	boven:	4.38	4.375
		onder:		4.375
30	1.0*h	boven:	5.00	5.000
		onder:		5.000
31	0.0*h	boven:	4.38	4.375
		onder:		4.375
32	1.0*h	boven:	5.00	5.000
		onder:		5.000
33	1.0*h	boven:	4.38	4.375
		onder:		4.375
34	0.0*h	boven:	4.38	4.375
		onder:		4.375
35	1.0*h	boven:	5.00	5.000
		onder:		5.000
36	0.0*h	boven:	4.38	4.375
		onder:		4.375
37	1.0*h	boven:	5.00	5.000
		onder:		5.000
38	0.0*h	boven:	4.38	4.375
		onder:		4.375
39	1.0*h	boven:	5.00	5.000
		onder:		5.000
40	0.0*h	boven:	4.49	4.493
		onder:		4.493
41	1.0*h	boven:	5.00	5.000
		onder:		5.000
42	0.0*h	boven:	4.53	4.528
		onder:		4.528
43	1.0*h	boven:	5.00	5.000
		onder:		5.000
44	1.0*h	boven:	4.38	4.375
		onder:		4.375
45	0.0*h	boven:	6.64	6.644
		onder:		6.644

46	0.0*h	boven:	6.64	6.644
		onder:		6.644
47	0.0*h	boven:	6.64	6.644
		onder:		6.644

Onderdeel.....:

KIPSTABILITEIT

Staafl	Plts. aangr.		l gaffel [m]	Kipsteunafstanden [m]
48	0.0*h	boven:	6.75	6.746
		onder:		6.746
49	1.0*h	boven:	6.64	6.644
		onder:		6.644
50	1.0*h	boven:	6.64	6.644
		onder:		6.644
51	1.0*h	boven:	6.64	6.644
		onder:		6.644
52	1.0*h	boven:	6.64	6.644
		onder:		6.644

TOETSING SPANNINGEN

Staafl	P/M	BC	Sit	Kl	Plaats	Norm	Artikel	Formule	Hoogste toetsing U.C. [N/mm ²]	Opm.
1	3	1	1	1	Begin	EN3-1-1	6.2.1(6)	N+D	0.179	42
2	2	2	1	1	Begin	EN3-1-1	6.2.1(6)	N+D	0.030	7
3	2	1	1	4	Staafl	EN3-1-1	6.3.3	(6.62)	0.064	15 47,129
4	3	1	1	1	Staafl	EN3-1-1	6.3.3	(6.61)	0.345	81
5	2	1	1	1	Staafl	EN3-1-1	6.3.3	(6.62)	0.026	6 47
6	3	1	1	1	Staafl	EN3-1-1	6.3.3	(6.61)	0.354	83
7	2	1	1	1	Einde	EN3-1-1	6.2.10	(6.45+6.31y)	0.046	11 47
8	3	1	1	1	Begin	EN3-1-1	6.2.1(6)	N+D	0.190	45
9	2	1	1	1	Staafl	EN3-1-1	6.3.3	(6.62)	0.029	7 47
10	3	1	1	1	Begin	EN3-1-1	6.2.1(6)	N+D	0.183	43
11	2	1	1	1	Staafl	EN3-1-1	6.3.3	(6.62)	0.020	5 47
12	2	2	1	1	Begin	EN3-1-1	6.2.1(6)	N+D	0.029	7
13	2	1	1	4	Staafl	EN3-1-1	6.3.3	(6.62)	0.073	16 47,129
14	1	1	1	1	My-max	EN3-1-1	6.2.9.1	(6.45+6.31y)	0.027	6
15	2	1	1	1	Begin	EN3-1-1	6.2.10	(6.45+6.31y)	0.018	4
16	1	1	1	1	Begin	EN3-1-1	6.2.1(6)	N+D	0.045	11
17	2	1	1	1	Staafl	EN3-1-1	6.3.3	(6.62)	0.033	8 47
18	1	1	1	1	My-max	EN3-1-1	6.2.9.1	(6.45+6.31y)	0.027	6
19	2	1	1	1	Staafl	EN3-1-1	6.3.3	(6.62)	0.049	12 47
20	1	1	1	1	Staafl	EN3-1-1	6.3.3	(6.61)	0.053	12
21	2	1	1	1	Staafl	EN3-1-1	6.3.3	(6.62)	0.036	9 47
22	1	1	1	1	My-max	EN3-1-1	6.2.9.1	(6.45+6.31y)	0.027	6
23	2	2	1	1	Begin	EN3-1-1	6.2.1(6)	N+D	0.027	6
24	1	1	1	1	Staafl	EN3-1-1	6.3.3	(6.61)	0.030	7
25	2				Staafl is onbelast					47,129,57
26	1	1	1	1	My-max	EN3-1-1	6.2.9.1	(6.45+6.31y)	0.027	6
27	2	1	1	4	Staafl	EN3-1-1	6.3.3	(6.62)	0.014	3 47,129
28	1	1	1	1	My-max	EN3-1-1	6.2.9.1	(6.45+6.31y)	0.027	6
29	2				Staafl is onbelast					47,57
30	1	1	1	1	Staafl	EN3-1-1	6.3.3	(6.61)	0.031	7
31	2	1	1	4	Staafl	EN3-1-1	6.3.3	(6.62)	0.019	4 47,129
32	1	1	1	1	My-max	EN3-1-1	6.2.9.1	(6.45+6.31y)	0.027	6
33	2	1	1	4	Staafl	EN3-1-1	6.3.3	(6.62)	0.076	17 47,129
34	2	2	1	1	Begin	EN3-1-1	6.2.1(6)	N+D	0.025	6
35	1	1	1	1	My-max	EN3-1-1	6.2.9.1	(6.45+6.31y)	0.027	6
36	2				Staafl is onbelast					47,129,57
37	1	1	1	1	My-max	EN3-1-1	6.2.9.1	(6.45+6.31y)	0.027	6
38	2	1	1	4	Staafl	EN3-1-1	6.3.3	(6.62)	0.019	4 47,129
39	1	1	1	1	My-max	EN3-1-1	6.2.9.1	(6.45+6.31y)	0.027	6
40	2	1	1	4	Staafl	EN3-1-1	6.3.3	(6.62)	0.010	2 47,129
41	1	1	1	1	Staafl	EN3-1-1	6.3.3	(6.61)	0.030	7
42	2	1	1	4	Staafl	EN3-1-1	6.3.3	(6.62)	0.022	5 47,129

Onderdeel.....:

TOETSING SPANNINGEN

Staafl	P/M	BC	Sit	Kl	Plaats	Norm	Artikel	Formule	Hoogste toetsing U.C. [N/mm ²]	Opm.
43	1	1	1	1	Staafl	EN3-1-1	6.3.3	(6.61)	0.030	7
44	2	1	1	4	Staafl	EN3-1-1	6.3.3	(6.62)	0.074	17 47,129
45	4	1	1	1	Staafl	EN3-1-1	6.3.3	(6.61)	0.622	146 47
46	4	1	1	1	Staafl	EN3-1-1	6.3.3	(6.61)	0.734	172 47
47	4	1	1	1	Staafl	EN3-1-1	6.3.3	(6.61)	0.718	169 47
48	4	1	1	1	Staafl	EN3-1-1	6.3.3	(6.61)	0.731	172 47
49	4	1	1	1	Einde	EN3-1-1	6.2.1(6)	N+D	0.295	69
50	4	1	1	1	Einde	EN3-1-1	6.2.1(6)	N+D	0.296	70

51 4 1 1 1 Einde EN3-1-1 6.2.1(6) N+D 0.322 76
 52 4 1 1 1 Einde EN3-1-1 6.2.1(6) N+D 0.292 69

Opmerkingen:

[47] Bij verlopende normaalkracht wordt de grootste drukkracht genomen.

[57] Staaf is (nagenoeg) onbelast.

[129] Bij berekening van klasse 4 profielen is gebruik gemaakt van de spanningsreductiemethode.

TOETSING DOORBUIGING

Staaft	Soort	Mtg	Lengte	Overst	Zeeg	u _{tot}	BC	Sit	u	Toelaatbaar
			[m]	I	J	[mm]			[mm]	[mm]
1	Dak	db	5.00	N	N	0.0	-0.8	3 1	Eind	-0.8 -20.0 0.004
4	Dak	db	5.00	N	N	0.0	-0.8	3 1	Eind	-0.8 -20.0 0.004
6	Dak	db	5.00	N	N	0.0	-0.8	3 1	Eind	-0.8 -20.0 0.004
8	Dak	db	5.00	N	N	0.0	-0.8	3 1	Eind	-0.8 -20.0 0.004
10	Dak	db	5.00	N	N	0.0	-0.8	3 1	Eind	-0.8 -20.0 0.004
14	Vloer	db	5.00	N	N	0.0	-1.1	3 1	Eind	-1.1 ±20.0 0.004
16	Vloer	db	5.00	N	N	0.0	-1.1	3 1	Eind	-1.1 ±20.0 0.004
18	Vloer	db	5.00	N	N	0.0	-1.1	3 1	Eind	-1.1 ±20.0 0.004
20	Vloer	db	5.00	N	N	0.0	-1.1	3 1	Eind	-1.1 ±20.0 0.004
22	Vloer	db	5.00	N	N	0.0	-1.1	3 1	Eind	-1.1 ±20.0 0.004
24	Vloer	db	5.00	N	N	0.0	-1.1	3 1	Eind	-1.1 ±20.0 0.004
26	Vloer	db	5.00	N	N	0.0	-1.1	3 1	Eind	-1.1 ±20.0 0.004
28	Vloer	db	5.00	N	N	0.0	-1.1	3 1	Eind	-1.1 ±20.0 0.004
30	Vloer	db	5.00	N	N	0.0	-1.1	3 1	Eind	-1.1 ±20.0 0.004
32	Vloer	db	5.00	N	N	0.0	-1.1	3 1	Eind	-1.1 ±20.0 0.004
35	Vloer	db	5.00	N	N	0.0	-1.1	3 1	Eind	-1.1 ±20.0 0.004
37	Vloer	db	5.00	N	N	0.0	-1.1	3 1	Eind	-1.1 ±20.0 0.004
39	Vloer	db	5.00	N	N	0.0	-1.1	3 1	Eind	-1.1 ±20.0 0.004
41	Vloer	db	5.00	N	N	0.0	-1.1	3 1	Eind	-1.1 ±20.0 0.004
43	Vloer	db	5.00	N	N	0.0	-1.1	3 1	Eind	-1.1 ±20.0 0.004

TOETSING HORIZONTALE VERPLAATSING

Staaft	BC	Sit	Lengte	u _{eind}	Toelaatbaar	Maatgevend
			[m]	[mm]	[mm]	[h/]
2	3	1	4.375	-2.1	14.6	300 scheefstand
3	3	1	4.375	-2.5	14.6	300 scheefstand
5	3	1	4.375	-3.3	14.6	300 scheefstand
7	3	1	4.375	-4.1	14.6	300 scheefstand
9	3	1	4.375	-3.4	14.6	300 scheefstand
11	3	1	4.375	-2.9	14.6	300 scheefstand
12	3	1	4.375	-2.2	14.6	300 scheefstand
13	3	1	4.375	-2.4	14.6	300 scheefstand
15	3	1	4.375	-2.2	14.6	300 scheefstand
17	3	1	4.375	-2.4	14.6	300 scheefstand
19	3	1	4.375	-2.4	14.6	300 scheefstand
21	3	1	4.375	-2.4	14.6	300 scheefstand
23	3	1	4.375	-2.1	14.6	300 scheefstand
25	3	1	4.375	-2.1	14.6	300 scheefstand
27	3	1	4.375	-2.1	14.6	300 scheefstand

Onderdeel.....

TOETSING HORIZONTALE VERPLAATSING

Staaft	BC	Sit	Lengte	u _{eind}	Toelaatbaar	Maatgevend
			[m]	[mm]	[mm]	[h/]
29	3	1	4.375	-2.1	14.6	300 scheefstand
31	3	1	4.375	-2.1	14.6	300 scheefstand
33	3	1	4.375	-2.1	14.6	300 scheefstand
34	3	1	4.375	-2.1	14.6	300 scheefstand
36	3	1	4.375	-2.1	14.6	300 scheefstand
38	3	1	4.375	-2.1	14.6	300 scheefstand
40	3	1	4.493	-2.1	15.0	300 scheefstand
42	3	1	4.528	-2.1	15.1	300 scheefstand
44	3	1	4.375	-2.1	14.6	300 scheefstand

TOETSING HOR. VERPLAATSING GLOBAAL

Er is een maximale horizontale verplaatsing van 0.0108 [m] gevonden bij knoop 7 en combinatie 3; belastingsituatie 1 (combinatietype 2). Bij een hoogte van 17.653 [m] levert dit h /1639 (toel.: h / 300).

Bijlage B Staalberekening connex

B - 1 Staalberekening connex