

PREMIUM
MOUNTING
TECHNOLOGIES

10
years
guarantee

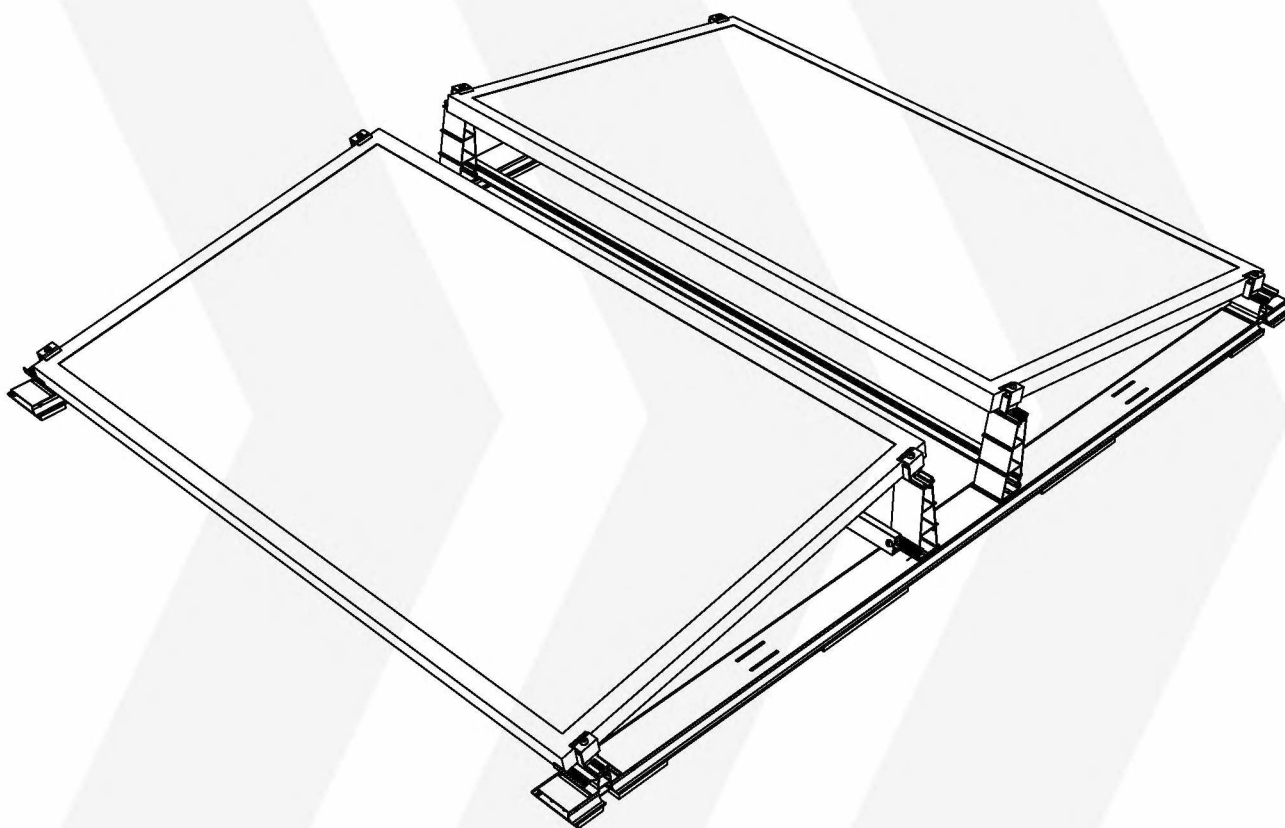

PRODUCT DATA SHEET

PMT EVO 2.0 EW 10° / 15°

PMT EVO 2.0 EW

THE UNCOMPROMISING FLAT-ROOF MOUNTING SYSTEM FOR LARGE-SCALE PHOTOVOLTAIC SYSTEMS

The intelligent revolutionization of the entire construction results in previously unattained performance in terms of building and thus investment security as well as an increase in economic efficiency thanks to the fast assembly. Right before starting the assembly, the advantage of the innovative Click-technology can be clearly seen. The short click-components do not only make the assembly more handy, but also provide the right dimension for the position of the individual components. This eliminates the need for time-consuming measuring within the system and prevents errors during set-up because the Click connections are matched with each other. No sharp small parts such as drilling screws are used during the entire assembly. Thanks to the drilling-free assembly, no sharp drill chips that could damage the sensitive roof cladding are produced. The load-transmitting system composite of extra-wide contact surfaces of the floor rails, tower, and base is reinforced by a multifunctional cross brace to maximise system stability. This extremely stable mounting system is the optimal basis for a profitable PV operation with regard to maximum cost-effectiveness from system acquisition costs, installation time, and building security.

THE ADVANTAGES

- › **Minimum ballast:** improved aerodynamics, increased system stability, latest wind channel evaluations, side cover plates for the reduction of lateral thrust due to wind (optional)
- › **Integrated safety precaution against fall:** circumferential safety rope system, certification according to DIN EN 795:2012 and CEN/TS 16415:2013 (in progress), and rope system for max. 3 persons (max. 300 kg), (optional)
- › **Ideal cable routing:** 3-fold edge clip holder, integrated cable duct cover, separate installation DC ± possible, separation distances +150 mm possible
- › **Conform to installation guidelines:** Compliance with module clamping ranges, drainage holes free according to assembly & installation guidelines, integrated module earthing (optional)
- › **Simple click-system:** non-interchangeable click connections, measurement-free assembly, detachable connections, minimisation of thermal linear expansion effects
- › **Optimum contact surface:** 115 mm wide continuous floor rail, integrated high-tech protective mat (all surfaces), guarantee of roof drainage, no plasticiser migration
- › **Universal module clamp:** universal clamp from 30 to 50 mm module height, simple click and screw connection, removable
- › **Variable dimensions of modules:** Module lengths from 1.570 to 2.005 mm, widths from 960 to 1.050 mm, suitable for 72-cell modules
- › **Maximum safety:** National Technical Approval Z-14.4-790 (extension applied for), UL 2703 (approval in process), lightning current carrying capacity according to DIN EN 62561-1 (VDE 0185-561-1):2013- 02 (expansion applied for)

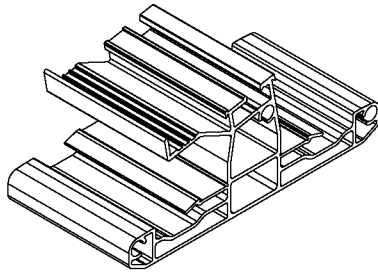



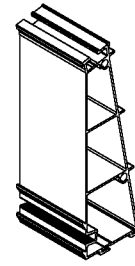







Detailed image of base



Detailed image of tower

TECHNICAL DATA

	Application	flat roof up to 10° Grad (<i>special projects on request</i>)
	Setting angle	10° and 15°
	Orientation	East/West
	Roofing cladding	foil, bitumen, gravel, greening, sheet metal, concrete, open space
	Module system dimensions	2345mm (10°/15°) from module edge to module edge at 200 mm Maintenance corridor (2205/2445 mm without or 300 mm with maintenance corridor; <i>special project on request</i>)
	Material	Exclusively high-quality aluminium EN-AW-6063-T3 and stainless steel and A2-70. No galvanized components and plastics used.
	Light system	Low weight of the mounting system of only 4,32 kg per module unit (double module unit from 0,96 kg/m²)
	High-Tech protective mat	An 11 mm thick high-tech protective mat with antislip coating for a maximum protection against plasticiser migration and roof cladding is pre-assembled on the mounting system.
	Approvals	<ul style="list-style-type: none"> - Lightning current carrying system according to DIN EN 62561 (VDE 0185-561-1);2013-02 - National technical approval Z-14.4-790 for the aerodynamical flat roof system - UL2703 test certificate for the US-market
	PV-module suitability	All common PV-module dimensions (<i>Special dimensions on request</i>) Width: 960-1050 mm Length: 1570-2005 mm Height: 30-50 mm

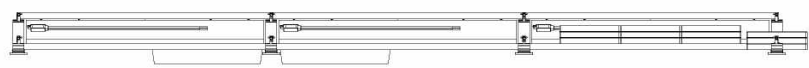

A

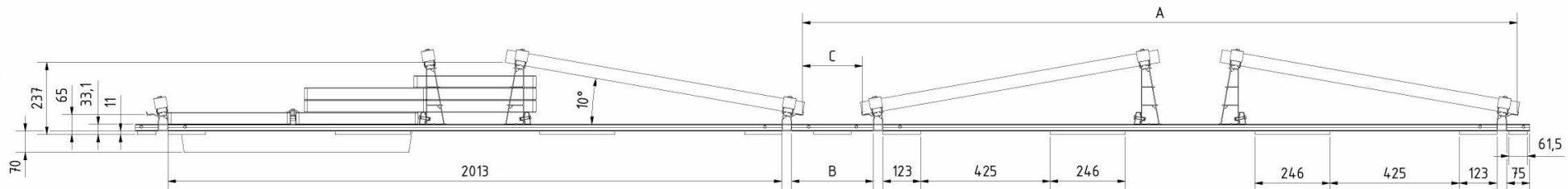
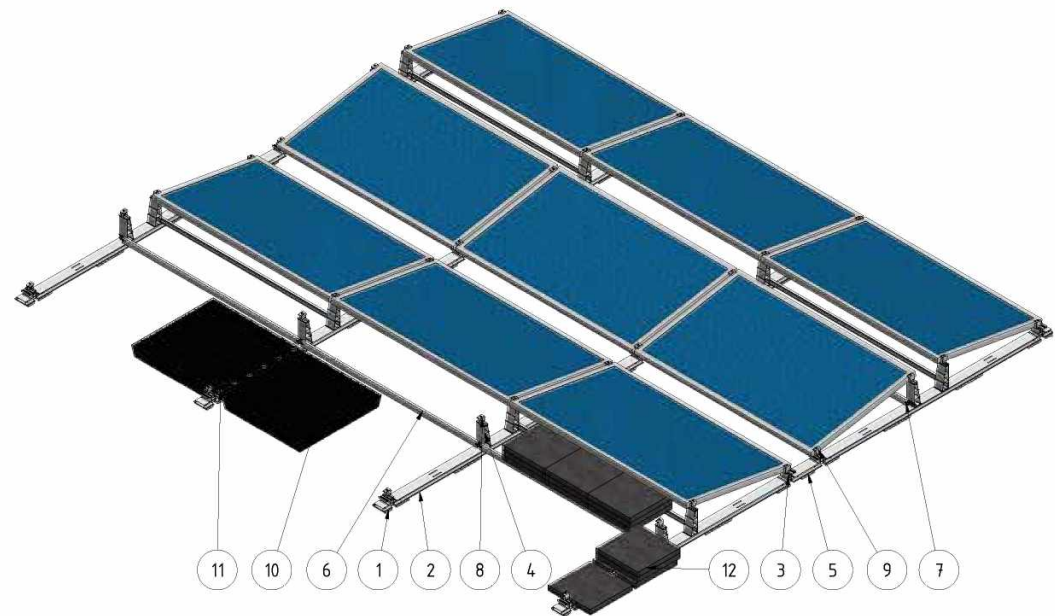
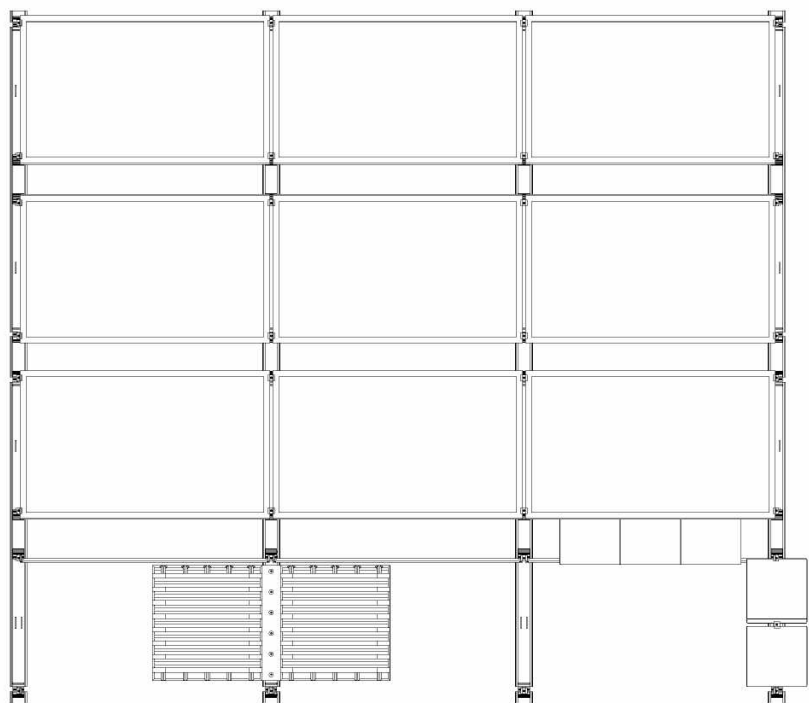
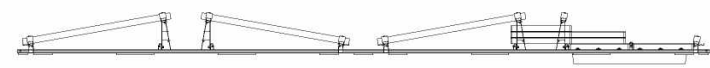

TEILELISTE		
OBJEKT	ANZAHL	BAUTEILNUMMER
1	8	EVO 2.0 AEBP Typ 75
2	8	EVO 2.0 HBP10 Typ 2013
3	8	EVO 2.0 B10 Typ 75
4	16	EVO 2.0 T10 Typ 75
5	4	EVO 2.0 V1BP Typ 267
6	10	EVO 2.0 QBS Typ 1648
7	20	S Typ M8x30
8	16	MK Typ 40
9	16	EK Typ 40
10	1	EVO 2.0 BW Typ 70
11	6	JF3-2H-4,8x19-E14
12	13	Ballaststein 40x40x4

Modul-Sprungmaße		
Maß A	Maß B	Maß C
2205	127	57
2345	267	197
2445	367	297

	PREMIUM MOUNTING TECHNOLOGIES	
	Allgemein-toleranz ISO 2768-m	
Datum 06.09.2018	Name a.herrzog	
Gezeichnet Kontrolliert Name	Premium Mounting Technologies GmbH & Co. KG Eisenplan 1 93506 Regensburg Tel. +49 941 9191-10 email: info@pmt-solutions.com www.pmt-solutions.com	
Status Änderungen Datum Name	2	

EVO 2.0 EW10

technisches Datenblatt



1

A2



The assembly instructions must be observed during assembly.
This assembly instruction can also be found in digital form under www.pmt.solutions/en/downloads or directly scan the QR code with your smart phone. *(Requirements: Your mobile terminal must be equipped with an appropriate app)*



Premium Mounting Technologies GmbH & Co. KG
Energiepark 1
D-95365 Rugendorf
T ^{DE} 
F ^{DE}  94597444
info@pmt.solutions
www.pmt.solutions

HOCHSCHULE COBURG
university of applied sciences



INGENIEURGRUPPE
KNÖRNSCHILD & KOLLEGEN

Further information: www.pmt.solutions
Subject to technical modifications.
2018© Premium Mounting Technologies GmbH & Co. KG

SERVICE HOTLINE

^{DE} 